

***Nidec***

All for dreams



*Control User Guide*

---

***Unidrive M600***

---

Part Number: 0478-0337-02

Issue: 2

## Original Instructions

For the purposes of compliance with the EU Machinery Directive 2006/42/EC, the English version of this manual is the Original Instructions. Manuals in other languages are Translations of the Original Instructions.

### Documentation

Manuals are available to download from the following locations: <http://www.drive-setup.com/ctdownloads>

The information contained in this manual is believed to be correct at the time of printing and does not form part of any contract. The manufacturer reserves the right to change the specification of the product and its performance, and the contents of the manual, without notice.

### Warranty and Liability

In no event and under no circumstances shall the manufacturer be liable for damages and failures due to misuse, abuse, improper installation, or abnormal conditions of temperature, dust, or corrosion, or failures due to operation outside the published ratings. The manufacturer is not liable for consequential and incidental damages. Contact the supplier of the dive for full details of the warranty terms.

### Environmental policy



Control Techniques Ltd operates an Environmental Management System (EMS) that conforms to the International Standard ISO 14001.

Further information on our Environmental Policy can be found at: <http://www.drive-setup.com/environment>

### Restriction of Hazardous Substances (RoHS)

The products covered by this manual comply with European and International regulations on the Restriction of Hazardous Substances including EU directive 2011/65/EU and the Chinese Administrative Measures for Restriction of Hazardous Substances in Electrical and Electronic Products.

### Disposal and Recycling (WEEE)

 	<p>When electronic products reach the end of their useful life, they must not be disposed of along with domestic waste but should be recycled by a specialist recycler of electronic equipment. Control Techniques products are designed to be easily dismantled into their major component parts for efficient recycling. The majority of materials used in the product are suitable for recycling.</p> <p>Product packaging is of good quality and can be re-used. Large products are packed in wooden crates. Smaller products are packaged in strong cardboard cartons which have a high recycled fibre content. Cartons can be re-used and recycled. Polythene, used in protective film and bags for wrapping the product, can be recycled. When preparing to recycle or dispose of any product or packaging, please observe local legislation and best practice.</p>
--	--

### REACH legislation

EC Regulation 1907/2006 on the Registration, Evaluation, Authorisation and restriction of Chemicals (REACH) requires the supplier of an article to inform the recipient if it contains more than a specified proportion of any substance which is considered by the European Chemicals Agency (ECHA) to be a Substance of Very High Concern (SVHC) and is therefore listed by them as a candidate for compulsory authorisation.

Further information on our compliance with REACH can be found at: <http://www.drive-setup.com/reach>

### Registered Office

#### Nidec Control Techniques Ltd

The Gro

Newtown

Powys

SY16 3BE

UK

Registered in England and Wales. Company Reg. No. 01236886.

### Copyright

The contents of this publication are believed to be correct at the time of printing. In the interests of a commitment to a policy of continuous development and improvement, the manufacturer reserves the right to change the specification of the product or its performance, or the contents of the guide, without notice.

All rights reserved. No parts of this guide may be reproduced or transmitted in any form or by any means, electrical or mechanical including photocopying, recording or by an information storage or retrieval system, without permission in writing from the publisher.

Copyright © December 2017 Nidec Control Techniques Ltd

# How to use this guide

This guide is intended to be used in conjunction with the appropriate *Power Installation Guide*. The *Power Installation Guide* gives information necessary to physically install the drive. This guide gives information on drive configuration, operation and optimization.

## NOTE

There are specific safety warnings throughout this guide, located in the relevant sections. In addition, Chapter 1 *Safety information* contains general safety information. It is essential that the warnings are observed and the information considered when working with or designing a system using the drive.

This map of the user guide helps to find the right sections for the task you wish to complete, but for specific information, refer to :

	Quick Start / bench testing	Familiarisation	System design	Programming and commissioning	Troubleshooting
1 Safety information	●	●	●	●	●
2 Product information		●	●		
3 Mechanical installation			●		
4 Electrical installation			●		
5 Getting started		●	●		
6 Basic parameters		●	●	●	
7 Running the motor	●	●	●	●	
8 Optimization			●	●	
9 NV media card operation			●	●	
10 Onboard PLC			●	●	
11 Advanced parameters			●	●	
12 Diagnostics					●
13 UL listing information			●	●	

---

# Contents

---

<b>1</b>	<b>Safety information .....</b>	<b>9</b>	<b>6</b>	<b>Running the motor .....</b>	<b>59</b>
1.1	Warnings, Cautions and Notes .....	9	6.1	Quick start connections .....	59
1.2	Important safety information. Hazards. Competence of designers and installers .....	9	6.2	Changing the operating mode .....	59
1.3	Responsibility .....	9	6.3	Quick start commissioning / start-up .....	64
1.4	Compliance with regulations .....	9	6.4	Quick start commissioning / start-up using Unidrive M Connect (V02.00.00.00 onwards) ....	72
1.5	Electrical hazards .....	9	6.5	Diagnostics .....	76
1.6	Stored electrical charge .....	9	<b>7</b>	<b>Optimization .....</b>	<b>77</b>
1.7	Mechanical hazards .....	9	7.1	Motor map parameters .....	77
1.8	Access to equipment .....	9	7.2	Maximum motor rated current .....	89
1.9	Environmental limits .....	9	7.3	Current limits .....	89
1.10	Hazardous environments .....	9	7.4	Motor thermal protection .....	89
1.11	Motor .....	10	7.5	Switching frequency .....	90
1.12	Mechanical brake control .....	10	7.6	High speed operation .....	90
1.13	Adjusting parameters .....	10	7.7	CT Modbus RTU specification .....	92
1.14	Electromagnetic compatibility (EMC) .....	10	<b>8</b>	<b>NV Media Card Operation .....</b>	<b>99</b>
<b>2</b>	<b>Product information .....</b>	<b>11</b>	8.1	Introduction .....	99
2.1	Introduction .....	11	8.2	NV Media Card support .....	99
2.2	Drive firmware version .....	11	8.3	Transferring data .....	100
2.3	Model number .....	11	8.4	Data block header information .....	101
2.4	Ratings .....	12	8.5	NV Media Card parameters .....	102
2.5	Operating modes .....	13	8.6	NV Media Card trips .....	103
2.6	Nameplate description .....	14	<b>9</b>	<b>Onboard PLC .....</b>	<b>104</b>
2.7	Options .....	15	9.1	Onboard PLC and Machine Control Studio .....	104
2.8	Drive features .....	17	9.2	Benefits .....	104
<b>3</b>	<b>Mechanical installation .....</b>	<b>18</b>	9.3	Features .....	104
3.1	Installing / removing option modules and keypads .....	18	9.4	Onboard PLC parameters .....	105
<b>4</b>	<b>Electrical installation .....</b>	<b>21</b>	9.5	Onboard PLC trips .....	105
4.1	24 Vdc supply .....	21			
4.2	Communication connections .....	22			
4.3	Control connections .....	23			
4.4	Safe Torque Off (STO) .....	28			
<b>5</b>	<b>Getting started .....</b>	<b>30</b>			
5.1	Understanding the display .....	30			
5.2	Keypad operation .....	30			
5.3	Menu structure .....	32			
5.4	Menu 0 .....	33			
5.5	Advanced menus .....	33			
5.6	Changing the operating mode .....	35			
5.7	Saving parameters .....	35			
5.8	Restoring parameter defaults .....	36			
5.9	Parameter access level and security .....	36			
5.10	Displaying parameters with non-default values only .....	37			
5.11	Displaying destination parameters only .....	37			
5.12	Communications .....	37			
<b>6</b>	<b>Basic parameters .....</b>	<b>38</b>			
6.1	Menu 0: Basic parameters .....	39			
6.2	Parameter descriptions .....	44			
6.3	Full descriptions .....	46			

<b>10</b>	<b>Advanced parameters .....</b>	<b>106</b>
10.1	Parameter ranges and Variable minimum/ maximums: .....	109
10.2	Menu 1: Frequency / speed reference .....	120
10.3	Menu 2: Ramps .....	124
10.4	Menu 3: Speed feedback and speed control ....	127
10.5	Menu 4: Torque and current control .....	131
10.6	Menu 5: Motor control .....	135
10.7	Menu 6: Sequencer and clock .....	140
10.8	Menu 7: Analog I/O .....	144
10.9	Menu 8: Digital I/O .....	148
10.10	Menu 9: Programmable logic, motorized pot, binary sum and timers .....	152
10.11	Menu 10: Status and trips .....	158
10.12	Menu 11: General drive set-up .....	160
10.13	Menu 12: Threshold detectors, variable selectors and brake control function .....	162
10.14	Menu 13: Standard motion controller .....	170
10.15	Menu 14: User PID controller .....	174
10.16	Menus 15, 16 and 17: Option module set-up ....	177
10.17	Menu 18: Application menu 1 .....	178
10.18	Menu 19: Application menu 2 .....	178
10.19	Menu 20: Application menu 3 .....	178
10.20	Menu 21: Second motor parameters .....	179
10.21	Menu 22: Additional Menu 0 set-up .....	181
<b>11</b>	<b>Diagnostics .....</b>	<b>183</b>
11.1	Status modes (Keypad and LED status) .....	183
11.2	Trip indications .....	183
11.3	Identifying a trip / trip source .....	184
11.4	Trips, Sub-trip numbers .....	185
11.5	Internal / Hardware trips .....	211
11.6	Alarm indications .....	211
11.7	Status indications .....	211
11.8	Programming error indications .....	212
11.9	Displaying the trip history .....	212
11.10	Behavior of the drive when tripped .....	212
<b>12</b>	<b>UL Information .....</b>	<b>213</b>
12.1	UL file reference .....	213
12.2	Option modules, kits and accessories .....	213
12.3	Enclosure ratings .....	213
12.4	Mounting .....	213
12.5	Environment .....	213
12.6	Electrical Installation .....	213
12.7	Motor overload protection and thermal memory retention .....	214
12.8	Electrical supply .....	214
12.9	External Class 2 supply .....	214
12.10	Requirement for Transient Surge Suppression .	214
12.11	Group Installation and Modular Drive Systems .	214
12.12	cUL requirements for 575 V frame size 7 and 8	214

# EU Declaration of Conformity

**Nidec Control Techniques Ltd**  
**The Gro**  
**Newtown**  
**Powys**  
**UK**  
**SY16 3BE**

This declaration is issued under the sole responsibility of the manufacturer. The object of the declaration is in conformity with the relevant European Union harmonization legislation. The declaration applies to the variable speed drive products shown below:

Model number	Interpretation	Nomenclature aaaa - bbc ddddde
aaaa	Basic series	M100, M101, M200, M201, M300, M400, M600, M700, M701, M702, M708, M709, M751, M753, M754, F300, H300, E200, E300, HS30, HS70, HS71, HS72, M000, RECT
bb	Frame size	01, 02, 03, 04, 05, 06, 07, 08, 09, 10, 11
c	Voltage rating	1 = 100 V, 2 = 200 V, 4 = 400 V, 5 = 575 V, 6 = 690 V
dddd	Current rating	Example 01000 = 100 A
e	Drive format	A = 6P Rectifier + Inverter (internal choke), D = Inverter, E = 6P Rectifier + Inverter (external choke), T = 12P Rectifier + Inverter (external choke)

The model number may be followed by additional characters that do not affect the ratings.

The variable speed drive products listed above have been designed and manufactured in accordance with the following European harmonized standards:

EN 61800-5-1:2007	Adjustable speed electrical power drive systems - Part 5-1: Safety requirements - Electrical, thermal and energy
EN 61800-3: 2004+A1:2012	Adjustable speed electrical power drive systems - Part 3: EMC requirements and specific test methods
EN 61000-6-2:2005	Electromagnetic compatibility (EMC) - Part 6-2: Generic standards - Immunity for industrial environments
EN 61000-6-4: 2007+ A1:2011	Electromagnetic compatibility (EMC) - Part 6-4: Generic standards - Emission standard for industrial environments
EN 61000-3-2:2014	Electromagnetic compatibility (EMC) - Part 3-2: Limits for harmonic current emissions (equipment input current ≤16 A per phase)
EN 61000-3-3:2013	Electromagnetic compatibility (EMC) - Part 3-3: Limitation of voltage changes, voltage fluctuations and flicker in public, low voltage supply systems, for equipment with rated current ≤16 A per phase and not subject to conditional connection

EN 61000-3-2:2014 Applicable where input current < 16 A. No limits apply for professional equipment where input power ≥1 kW.

These products comply with the Restriction of Hazardous Substances Directive (2011/65/EU), the Low Voltage Directive (2014/35/EU) and the Electromagnetic Compatibility Directive (2014/30/EU).



**G Williams**  
**Vice President, Technology**  
**Date: 6th September 2017**

These electronic drive products are intended to be used with appropriate motors, controllers, electrical protection components and other equipment to form complete end products or systems. Compliance with safety and EMC regulations depends upon installing and configuring drives correctly, including using the specified input filters.

The drives must be installed only by professional installers who are familiar with requirements for safety and EMC. Refer to the Product Documentation. An EMC data sheet is available giving detailed information. The assembler is responsible for ensuring that the end product or system complies with all the relevant laws in the country where it is to be used.

# EU Declaration of Conformity (including 2006 Machinery Directive)

Nidec Control Techniques Ltd  
The Gro  
Newtown  
Powys  
UK  
SY16 3BE

This declaration is issued under the sole responsibility of the manufacturer. The object of the declaration is in conformity with the relevant Union harmonization legislation. The declaration applies to the variable speed drive products shown below:

Model No.	Interpretation	Nomenclature aaaa - bbc ddddde
aaaa	Basic series	M600, M700, M701, M702, M708, M709, M751, M753, M754, F300, H300, E200, E300, HS70, HS71, HS72, M000, RECT
bb	Frame size	01, 02, 03, 04, 05, 06, 07, 08, 09, 10, 11
c	Voltage rating	1 = 100 V, 2 = 200 V, 4 = 400 V, 5 = 575 V, 6 = 690 V
dddd	Current rating	Example 01000 = 100 A
e	Drive format	A = 6P Rectifier + Inverter (internal choke), D = Inverter, E = 6P Rectifier + Inverter (external choke), T = 12P Rectifier + Inverter (external choke)

The model number may be followed by additional characters that do not affect the ratings.

**This declaration relates to these products when used as a safety component of a machine. Only the Safe Torque Off function may be used for a safety function of a machine. None of the other functions of the drive may be used to carry out a safety function.**

These products fulfil all the relevant provisions of the Machinery Directive 2006/42/EC and the Electromagnetic Compatibility Directive (2014/30/EU). EC type examination has been carried out by the following notified body:

TUV Rheinland Industrie Service GmbH  
Am Grauen Stein  
D-51105 Köln  
Germany

The harmonized standards used are shown below:  
EC type-examination certificate numbers:  
01/205/5270.02/17 dated 2017-08-28

Notified body identification number: 0035

EN 61800-5-1:2016	Adjustable speed electrical power drive systems - Part 5-2: Safety requirements - Functional
EN 61800-5-1:2016 (in extracts)	Adjustable speed electrical power drive systems - Part 5-1: Safety requirements - Electrical, thermal and energy
EN 61800-3: 2004+A1:2012	Adjustable speed electrical power drive systems - Part 3: EMC requirements and specific test methods
EN ISO 13849-1:2015	Safety of Machinery, Safety-related parts of control systems, General principles for design
EN 62061:2005 + AC:2010 + A1:2013 + A2:2015	Safety of machinery, Functional safety of safety related electrical, electronic and programmable electronic control systems
IEC 61508 Parts 1 - 7:2010	Functional safety of electrical/ electronic/programmable electronic safety-related systems

Person authorised to complete the technical file:

P Knight  
Conformity Engineer  
Newtown, Powys, UK

DoC authorised by:



G. Williams

Vice President, Technology

Date: 6th September 2017

Place: Newtown, Powys, UK

#### IMPORTANT NOTICE

These electronic drive products are intended to be used with appropriate motors, controllers, electrical protection components and other equipment to form complete end products or systems. It is the responsibility of the installer to ensure that the design of the complete machine, including its safety-related control system, is carried out in accordance with the requirements of the Machinery Directive and any other relevant legislation. The use of a safety-related drive in itself does not ensure the safety of the machine. Compliance with safety and EMC regulations depends upon installing and configuring drives correctly, including using the specified input filters. The drive must be installed only by professional installers who are familiar with requirements for safety and EMC. The assembler is responsible for ensuring that the end product or system complies with all relevant laws in the country where it is to be used. For more information regarding Safe Torque Off, refer to the Product Documentation.

# 1 Safety information

## 1.1 Warnings, Cautions and Notes



A Warning contains information which is essential for avoiding a safety hazard.



A Caution contains information which is necessary for avoiding a risk of damage to the product or other equipment.

### NOTE

A Note contains information which helps to ensure correct operation of the product.

## 1.2 Important safety information. Hazards. Competence of designers and installers

This guide applies to products which control electric motors either directly (drives) or indirectly (controllers, option modules and other auxiliary equipment and accessories). In all cases the hazards associated with powerful electrical drives are present, and all safety information relating to drives and associated equipment must be observed.

Specific warnings are given at the relevant places in this guide.

Drives and controllers are intended as components for professional incorporation into complete systems. If installed incorrectly they may present a safety hazard. The drive uses high voltages and currents, carries a high level of stored electrical energy, and is used to control equipment which can cause injury. Close attention is required to the electrical installation and the system design to avoid hazards either in normal operation or in the event of equipment malfunction. System design, installation, commissioning/start-up and maintenance must be carried out by personnel who have the necessary training and competence. They must read this safety information and this guide carefully.

## 1.3 Responsibility

It is the responsibility of the installer to ensure that the equipment is installed correctly with regard to all instructions given in this guide. They must give due consideration to the safety of the complete system, so as to avoid the risk of injury both in normal operation and in the event of a fault or of reasonably foreseeable misuse.

The manufacturer accepts no liability for any consequences resulting from inappropriate, negligent or incorrect installation of the equipment.

## 1.4 Compliance with regulations

The installer is responsible for complying with all relevant regulations, such as national wiring regulations, accident prevention regulations and electromagnetic compatibility (EMC) regulations. Particular attention must be given to the cross-sectional areas of conductors, the selection of fuses or other protection, and protective ground (earth) connections.

This guide contains instructions for achieving compliance with specific EMC standards.

All machinery to be supplied within the European Union in which this product is used must comply with the following directives:

2006/42/EC Safety of machinery.

2014/30/EU: Electromagnetic Compatibility.

## 1.5 Electrical hazards

The voltages used in the drive can cause severe electrical shock and/or burns, and could be lethal. Extreme care is necessary at all times when working with or adjacent to the drive. Hazardous voltage may be present in any of the following locations:

- AC and DC supply cables and connections
- Output cables and connections
- Many internal parts of the drive, and external option units

Unless otherwise indicated, control terminals are single insulated and must not be touched.

The supply must be disconnected by an approved electrical isolation device before gaining access to the electrical connections.

The STOP and Safe Torque Off functions of the drive do not isolate dangerous voltages from the output of the drive or from any external option unit.

The drive must be installed in accordance with the instructions given in this guide. Failure to observe the instructions could result in a fire hazard.

## 1.6 Stored electrical charge

The drive contains capacitors that remain charged to a potentially lethal voltage after the AC supply has been disconnected. If the drive has been energized, the AC supply must be isolated at least ten minutes before work may continue.

## 1.7 Mechanical hazards

Careful consideration must be given to the functions of the drive or controller which might result in a hazard, either through their intended behaviour or through incorrect operation due to a fault. In any application where a malfunction of the drive or its control system could lead to or allow damage, loss or injury, a risk analysis must be carried out, and where necessary, further measures taken to reduce the risk - for example, an over-speed protection device in case of failure of the speed control, or a fail-safe mechanical brake in case of loss of motor braking.

**With the sole exception of the Safe Torque Off function, none of the drive functions must be used to ensure safety of personnel, i.e. they must not be used for safety-related functions.**

The Safe Torque Off function may be used in a safety-related application. The system designer is responsible for ensuring that the complete system is safe and designed correctly according to the relevant safety standards.

The design of safety-related control systems must only be done by personnel with the required training and experience. The Safe Torque Off function will only ensure the safety of a machine if it is correctly incorporated into a complete safety system. The system must be subject to a risk assessment to confirm that the residual risk of an unsafe event is at an acceptable level for the application.

## 1.8 Access to equipment

Access must be restricted to authorized personnel only. Safety regulations which apply at the place of use must be complied with.

## 1.9 Environmental limits

Instructions in this guide regarding transport, storage, installation and use of the equipment must be complied with, including the specified environmental limits. This includes temperature, humidity, contamination, shock and vibration. Drives must not be subjected to excessive physical force.

## 1.10 Hazardous environments

The equipment must not be installed in a hazardous environment (i.e. a potentially explosive environment).

## 1.11 Motor

The safety of the motor under variable speed conditions must be ensured.

To avoid the risk of physical injury, do not exceed the maximum specified speed of the motor.

Low speeds may cause the motor to overheat because the cooling fan becomes less effective, causing a fire hazard. The motor should be installed with a protection thermistor. If necessary, an electric forced vent fan should be used.

The values of the motor parameters set in the drive affect the protection of the motor. The default values in the drive must not be relied upon. It is essential that the correct value is entered in the Motor Rated Current parameter.

## 1.12 Mechanical brake control

Any brake control functions are provided to allow well co-ordinated operation of an external brake with the drive. While both hardware and software are designed to high standards of quality and robustness, they are not intended for use as safety functions, i.e. where a fault or failure would result in a risk of injury. In any application where the incorrect operation of the brake release mechanism could result in injury, independent protection devices of proven integrity must also be incorporated.

## 1.13 Adjusting parameters

Some parameters have a profound effect on the operation of the drive. They must not be altered without careful consideration of the impact on the controlled system. Measures must be taken to prevent unwanted changes due to error or tampering.

## 1.14 Electromagnetic compatibility (EMC)

Installation instructions for a range of EMC environments are provided in the relevant Power Installation Guide. If the installation is poorly designed or other equipment does not comply with suitable standards for EMC, the product might cause or suffer from disturbance due to electromagnetic interaction with other equipment. It is the responsibility of the installer to ensure that the equipment or system into which the product is incorporated complies with the relevant EMC legislation in the place of use.

## 2 Product information

### 2.1 Introduction

#### Universal AC and servo drive

Unidrive M600 delivers maximum machine performance with sensorless induction and sensorless permanent magnet motor control, for dynamic and efficient machine operation. An optional encoder port can be used for precise closed loop velocity applications and digital lock / frequency following.

#### Features

- Universal high performance drive for induction and sensorless permanent magnet motors.
- Onboard IEC 61131-3 programmable automation
- NV Media Card for parameter copying and data storage
- EIA 485 serial communications interface
- Single channel Safe Torque Off (STO) input

#### Optional features

- Select up to three option modules

### 2.2 Drive firmware version

This product is supplied with the latest firmware version. If this drive is to be connected to an existing system or machine, all drive firmware versions should be verified to confirm the same functionality as drives of the same model already present. This may also apply to drives returned from an Nidec Industrial Automation Service Centre or Repair Centre. If there is any doubt please contact the supplier of the product.

The firmware version of the drive can be checked by looking at Pr **00.050** {11.029}.

### 2.3 Model number

The way in which the model numbers for the Unidrive M600 range are formed is illustrated below:

Figure 2-1 Model number

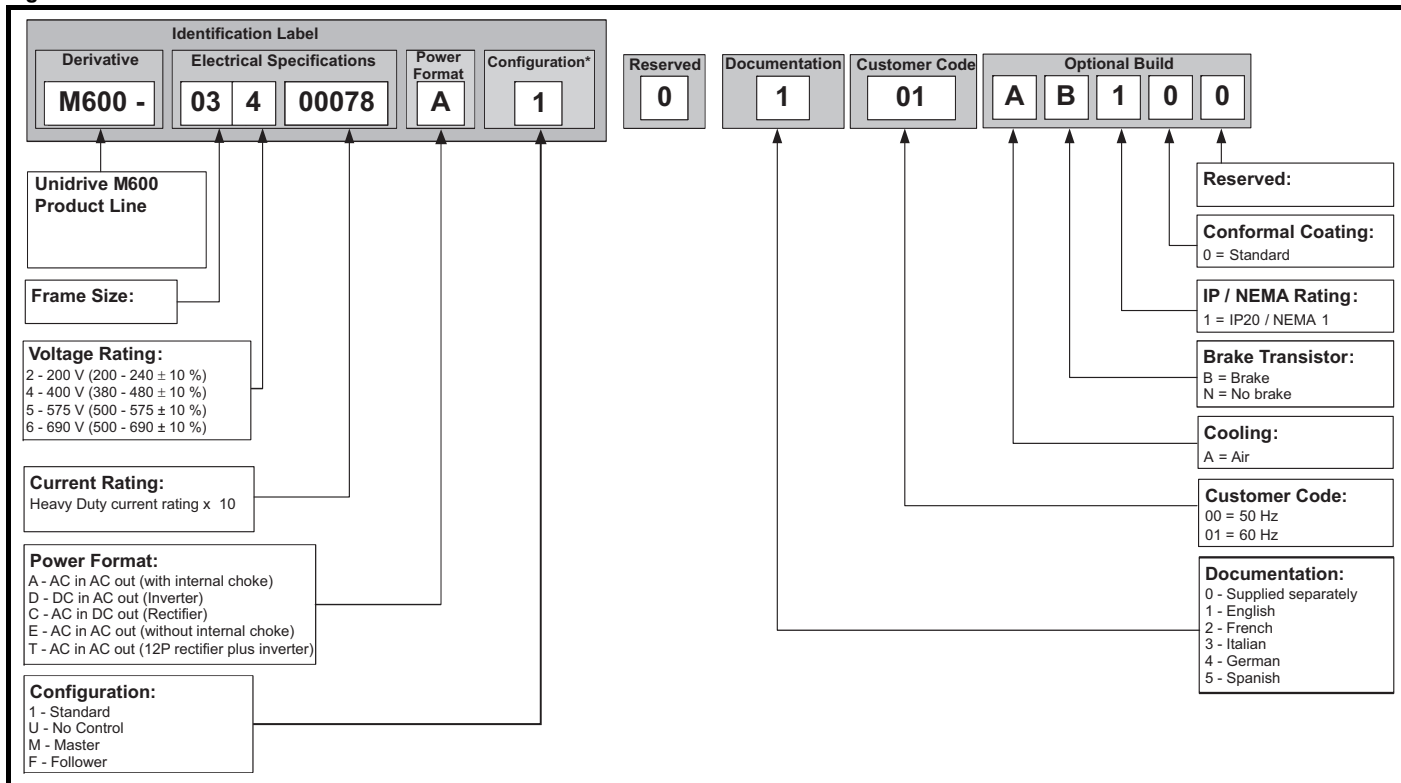

\* Only shown on Frame 9 to 11 identification label.

#### NOTE

For simplicity, a Frame 9 drive with no internal choke (i.e. model 09xxxxxE) is referred to as a Frame 9E and a Frame 9 drive with an internal choke (i.e. model 09xxxxxA) is referred to as a Frame 9A. Any reference to Frame 9 is applicable to both sizes 9E and 9A.

## 2.4 Ratings

The drive is dual rated.  
 The setting of the motor rated current determines which rating applies - Heavy Duty or Normal Duty.  
 The two ratings are compatible with motors designed to IEC60034.  
 The graph aside illustrates the difference between Normal Duty and Heavy Duty with respect to continuous current rating and short term overload limits.

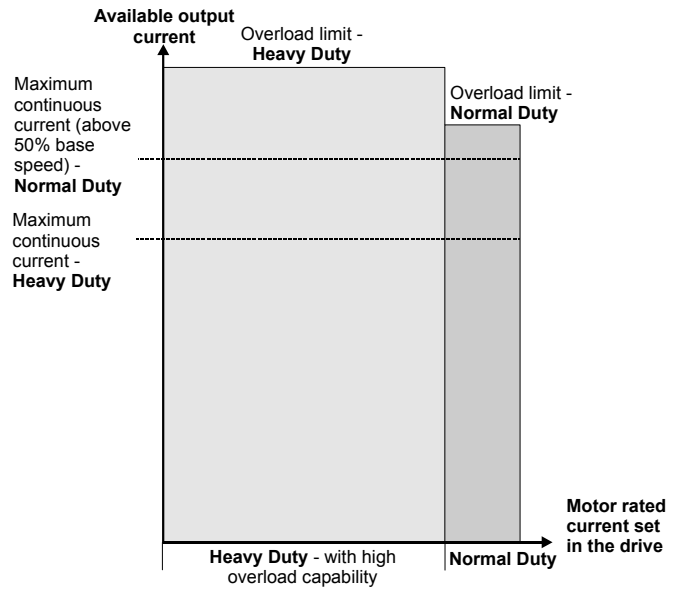

Normal Duty	Heavy Duty (default)
-------------	----------------------

For applications which use Self ventilated (TENV/TEFC) induction motors and require a low overload capability, and full torque at low speeds is not required (e.g. fans, pumps).  
 Self ventilated (TENV/TEFC) induction motors require increased protection against overload due to the reduced cooling effect of the fan at low speed. To provide the correct level of protection the  $I^2t$  software operates at a level which is speed dependent. This is illustrated in the graph below.

**NOTE**

The speed at which the low speed protection takes effect can be changed by the setting of *Low Speed Thermal Protection Mode* (04.025). The protection starts when the motor speed is below 15 % of base speed when Pr **04.025** = 0 (default) and below 50 % when Pr **04.025** = 1.

For constant torque applications or applications which require a high overload capability, or full torque is required at low speeds (e.g. winders, hoists).  
 The thermal protection is set to protect force ventilated induction motors and permanent magnet servo motors by default.

**NOTE**

If the application uses a self ventilated (TENV/TEFC) induction motor and increased thermal protection is required for speeds below 50 % base speed, then this can be enabled by setting *Low Speed Thermal Protection Mode* (04.025) = 1.

Operation of motor $I^2t$ protection	
--------------------------------------	--

Motor  $I^2t$  protection is fixed as shown below and is compatible with:

- Self ventilated (TENV/TEFC) induction motors

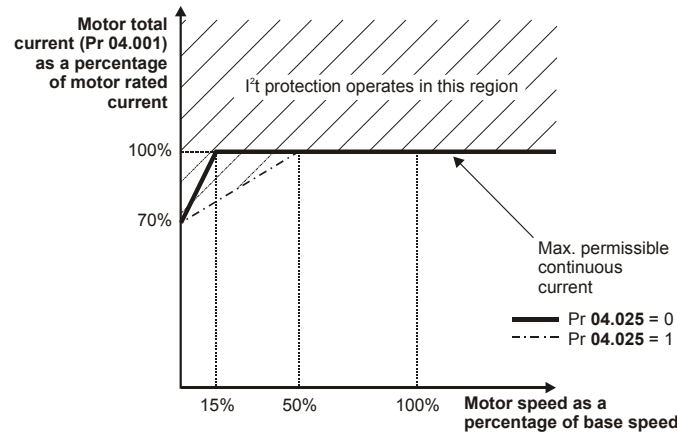

Motor  $I^2t$  protection defaults to be compatible with:

- Forced ventilation induction motors
- Permanent magnet servo motors

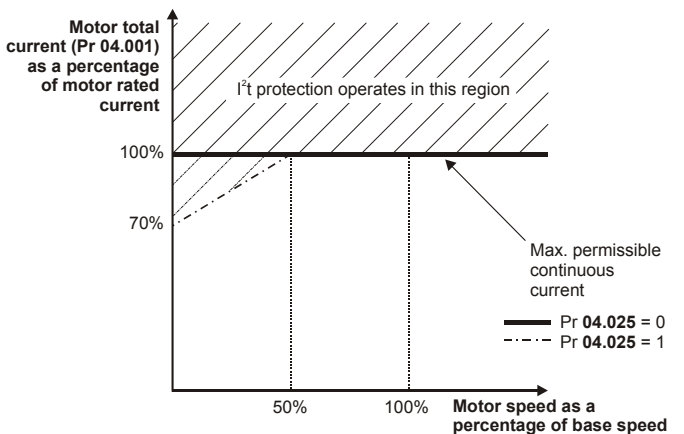

## 2.5 Operating modes

The drive is designed to operate in any of the following modes:

Open loop mode

- Open loop vector mode
- Fixed V/F mode (V/Hz)
- Quadratic V/F mode (V/Hz)

RFC - A

- With position feedback sensor (requires optional SI-Encoder module)
- Without position feedback sensor (Sensorless)

RFC - S

- Without position feedback sensor (Sensorless)

Regen mode

### 2.5.1 Open loop mode

The drive applies power to the motor at frequencies varied by the user. The motor speed is a result of the output frequency of the drive and slip due to the mechanical load. The drive can improve the speed control of the motor by applying slip compensation. The performance at low speed depends on whether V/F mode or open loop vector mode is selected.

#### Open loop vector mode

The voltage applied to the motor is directly proportional to the frequency except at low speed where the drive uses motor parameters to apply the correct voltage to keep the flux constant under varying load conditions.

Typically 100 % torque is available down to 1 Hz for a 50 Hz motor.

#### Fixed V/F mode

The voltage applied to the motor is directly proportional to the frequency except at low speed where a voltage boost is provided which is set by the user. This mode can be used for multi-motor applications.

Typically 100 % torque is available down to 4 Hz for a 50 Hz motor.

#### Quadratic V/F mode

The voltage applied to the motor is directly proportional to the square of the frequency except at low speed where a voltage boost is provided which is set by the user. This mode can be used for running fan or pump applications with quadratic load characteristics or for multi-motor applications. This mode is not suitable for applications requiring a high starting torque.

### 2.5.2 RFC-A mode

Rotor Flux Control for Asynchronous (induction) motors (**RFC-A**) encompasses closed loop vector control with and without a position feedback device.

**With position feedback** (requires optional SI-Encoder module)

For use with induction motors with a feedback device installed. The drive directly controls the speed of the motor using the feedback device to ensure the rotor speed is exactly as demanded. Motor flux is accurately controlled at all times to provide full torque all the way down to zero speed.

**Without position feedback (Sensorless)**

Sensorless mode provides closed loop control without the need for position feedback by using current, voltages and key operating motor parameters to estimate the motor speed. It can eliminate instability traditionally associated with open loop control such as operating large motors with light loads at low frequencies.

### 2.5.3 RFC- S

Rotor Flux Control for Synchronous (permanent magnet brushless) motors (**RFC-S**) provides closed loop control without a position feedback device.

**Without position feedback**

For use with permanent magnet brushless motors without a feedback device installed.

Flux control is not required because the motor is self excited by the permanent magnets which form part of the rotor.

Full torque is available all the way down to zero speed, with salient motors.

### 2.5.4 Regen mode

For use as a regenerative front end for four quadrant operation.

Regen operation allows bi-directional power flow to and from the AC supply. This provides far greater efficiency levels in applications which would otherwise dissipate large amounts of energy in the form of heat in a braking resistor.

The harmonic content of the input current is negligible due to the sinusoidal nature of the waveform when compared to a conventional bridge rectifier or SCR/thyristor front end.

## 2.6 Nameplate description

Figure 2-2 Typical drive rating labels

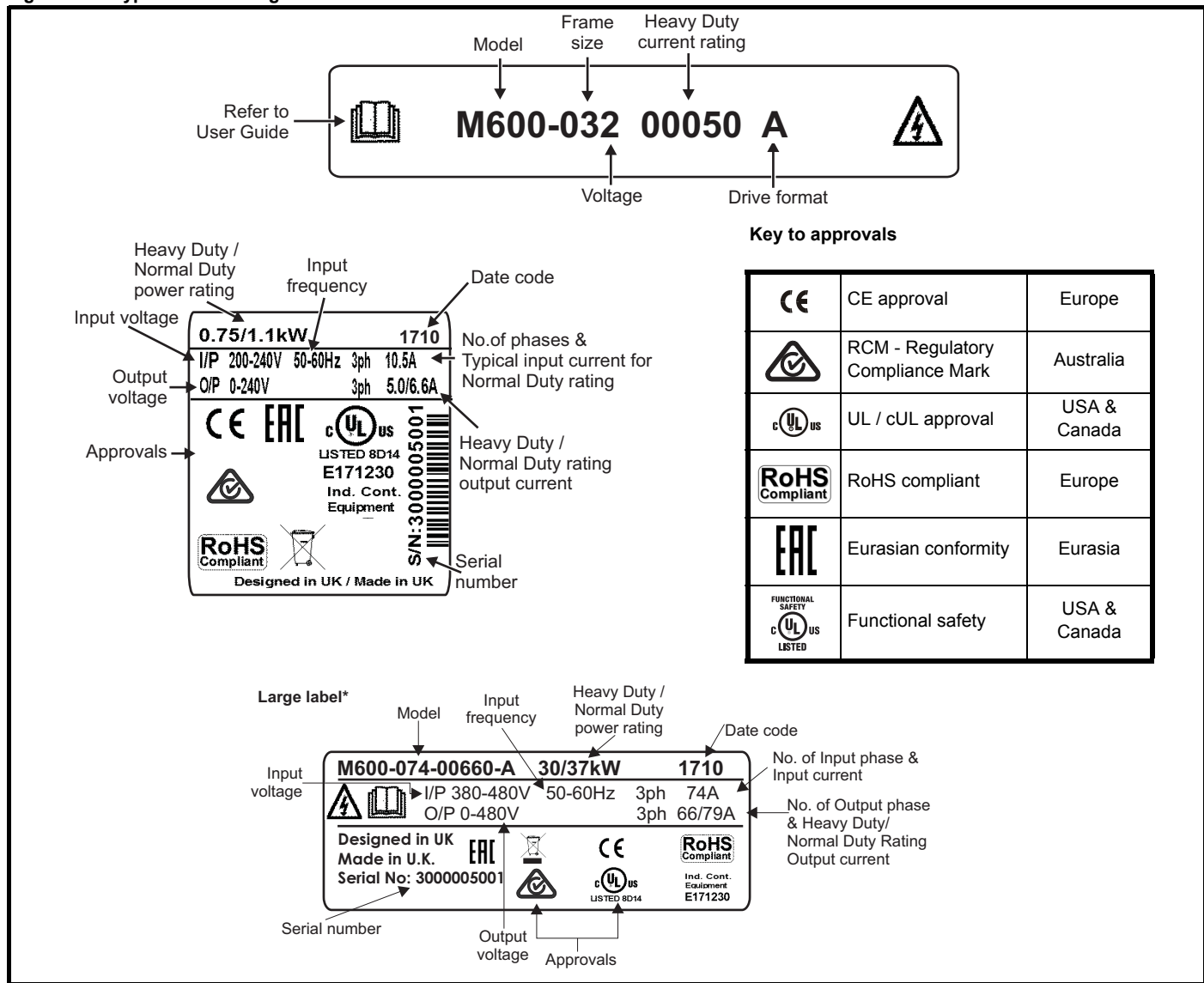

\* This label is only applicable to Size 7 and above.

Refer to Figure 2-1 *Model number* on page 11 for further information relating to the labels.

### NOTE

#### Date code format

The date code is four numbers. The first two numbers indicate the year and the remaining numbers indicate the week of the year in which the drive was built.

#### Example:

A date code of **1710** would correspond to week 10 of year 2017.

## 2.7 Options

Figure 2-3 Options available with the drive

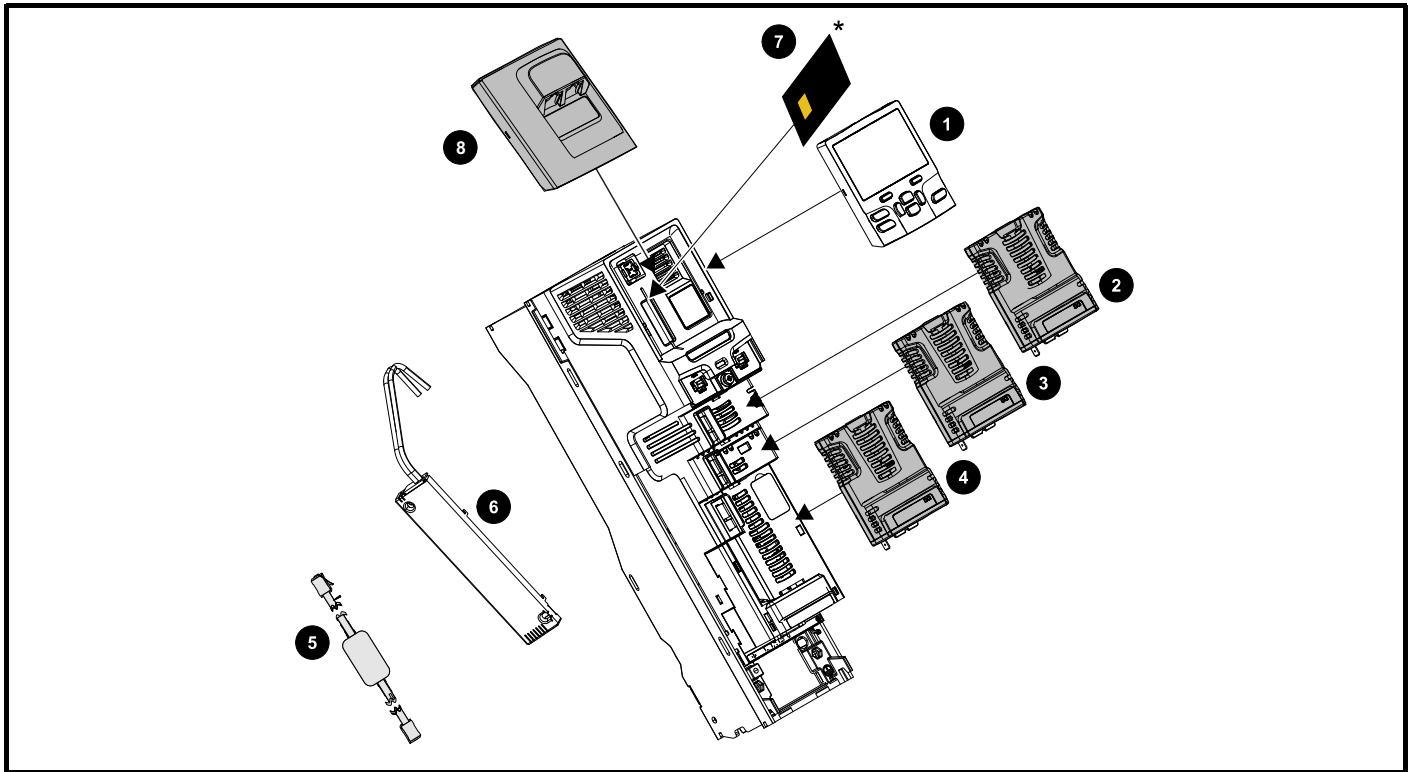

1. Keypad
2. Option module slot 1
3. Option module slot 2
4. Option module slot 3
5. CT USB Comms cable
6. Internal braking resistor
7. NV media card (\* For further information refer to chapter 8 *NV Media Card Operation* on page 99).
8. KI-485 comms adaptor













Be aware of possible live terminals when inserting or removing the NV media card.





**WARNING**

All standard option modules are color-coded in order to make identification easy. All modules have an identification label on top of the module. Standard option modules can be installed to any of the available option slots on the drive. The following tables shows the color-code key and gives further details on their function.



**Table 2-1 Option module identification**

Type	Option module	Color	Name	Further Details
Fieldbus		N/A	KI-485 Adaptor	<b>EIA 485 Comms Adaptor</b> EIA 485 Comms adaptor provides EIA 485 communication interface. This adaptor supports 115 k Baud, node addresses between 1 to 16 and 8 1 NP M serial mode.
		Purple	SI-PROFIBUS	<b>PROFIBUS option</b> PROFIBUS adapter for communications with the drive
		Medium Grey	SI-DeviceNet	<b>DeviceNet option</b> DeviceNet adapter for communications with the drive
		Light Grey	SI-CANopen	<b>CANopen option</b> CANopen adapter for communications with the drive
		Beige	SI-Ethernet	External Ethernet module that supports EtherNet/IP, Modbus TCP/IP and RTMoE. The module can be used to provide high speed drive access, global connectivity and integration with IT network technologies, such as wireless networking
		Yellow Green	SI-PROFINET V2	<b>PROFINET V2 option</b> PROFINET V2 adapter for communications with the drive Note: PROFINET V2 replaces PROFINET RT.
		Brown Red	SI-EtherCAT	<b>EtherCAT option</b> EtherCAT adapter for communications with the drive
Automation (I/O expansion)		Orange	SI-I/O	<b>Extended I/O</b> Increases the I/O capability by adding the following combinations: <ul style="list-style-type: none"> <li>• Digital I/O</li> <li>• Digital Inputs</li> <li>• Analog Inputs (differential or single ended)</li> <li>• Analog Output</li> <li>• Relays</li> </ul>
Feedback		Light Brown	SI-Encoder	Incremental encoder input interface module. Provides Closed loop Rotor Flux Control for induction motors (RFC-A) on M600.
		Dark Brown	SI-Universal Encoder	Additional combined encoder input and output interface supporting Incremental, SinCos, HIPERFACE, EnDAT and SSI encoders.
Safety		Yellow	SI-Safety	Safety module that provides an intelligent, programmable solution to meet the IEC 61800-5-2 functional safety standard

**Table 2-2 Keypad identification**

Type	Keypad	Name	Further Details
Keypad		KI-Keypad	<b>LCD keypad option</b> Keypad with an LCD display
		KI-Keypad RTC	<b>LCD keypad option</b> Keypad with an LCD display and real time clock
		Remote-Keypad RTC	<b>Remote LCD keypad option</b> Remote Keypad with an LCD display and real time clock
		Remote-Keypad	<b>Remote LCD keypad option</b> Remote Keypad with an LCD display.

**Table 2-3 Additional options**

Type	Option	Name	Further Details
Back-up		SD Card Adaptor	<b>SD Card Adaptor</b> Allows the drive to use an SD card for drive back-up
		SMARTCARD	<b>SMARTCARD</b> Used for parameter back-up with the drive

## 2.8 Drive features

**Figure 2-4 Features of the drive control section**

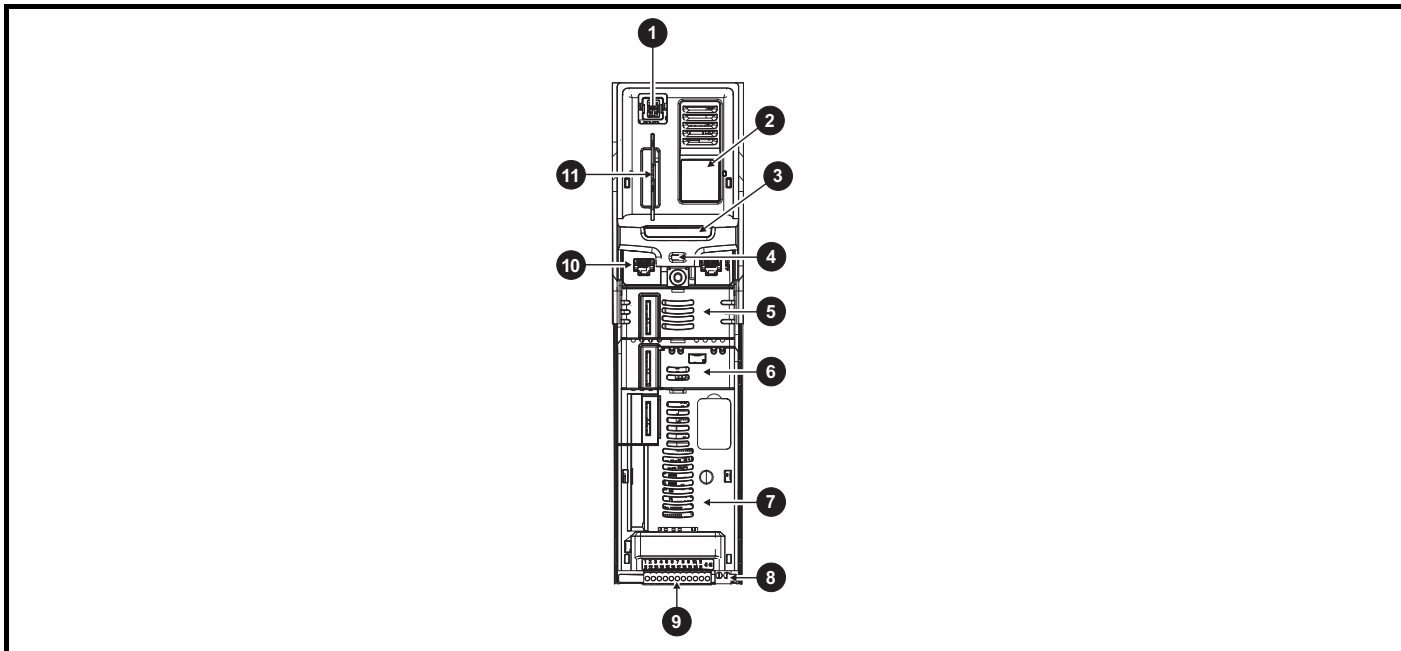

**Key**

- |                         |                         |                         |
|-------------------------|-------------------------|-------------------------|
| 1. Keypad connection    | 2. Rating label         | 3. Identification label |
| 4. Status LED           | 5. Option module slot 1 | 6. Option module slot 2 |
| 7. Option module slot 3 | 8. Relay connections    | 9. Control connections  |
| 10. Communications port | 11. NV media card slot  |                         |

## 3 Mechanical installation

### 3.1 Installing / removing option modules and keypads



Power down the drive before installing / removing the option module. Failure to do so may result in damage to the product.

**CAUTION**

Figure 3-1 Installation of an option module

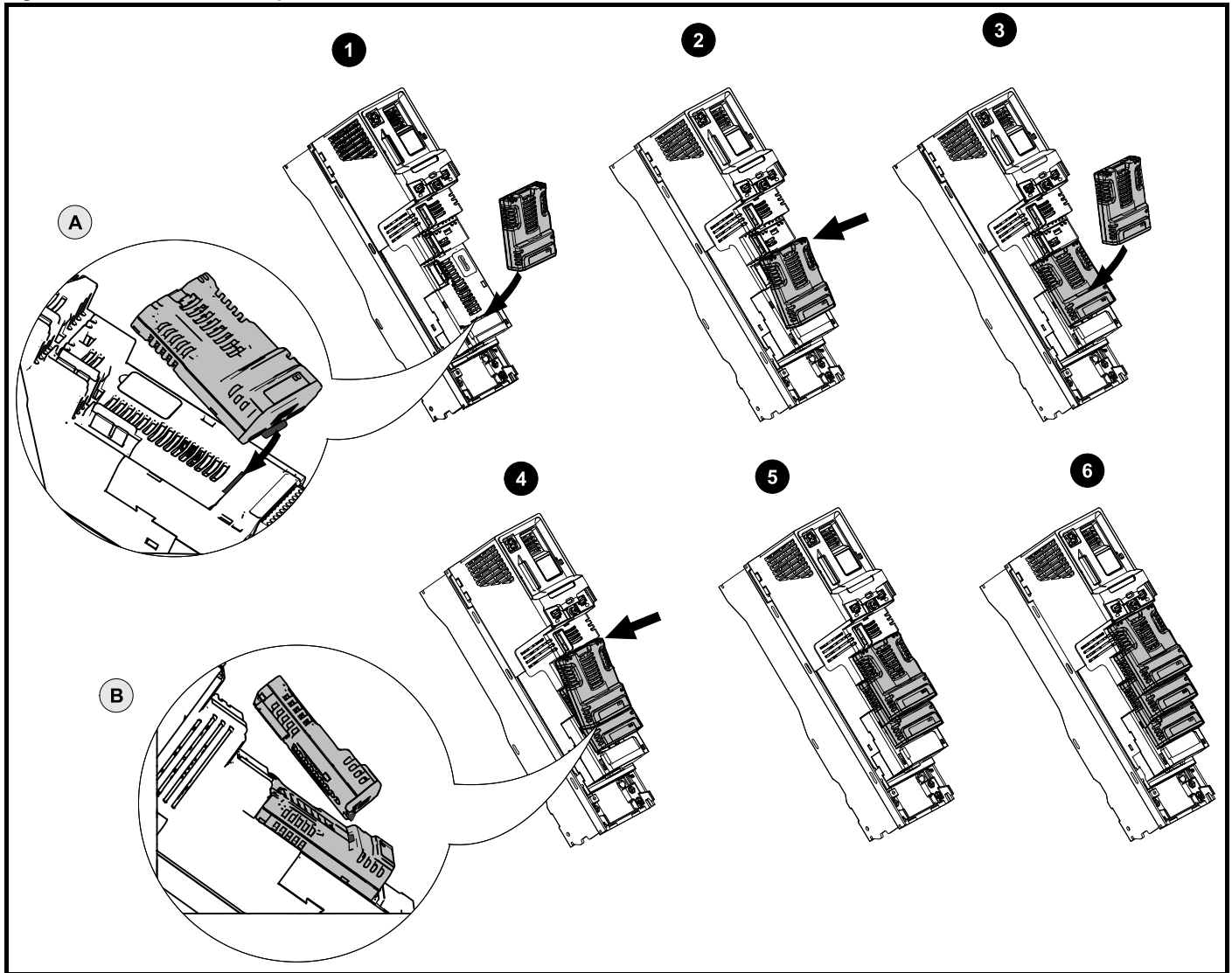

#### Installing the first option module

**NOTE**

Option module slots must be used in the following order: slot 3, slot 2 and slot 1 (refer to Figure 2-3 *Options available with the drive* on page 15 for slot numbers).

- Move the option module in direction shown (1).
- Align and insert the option module tab in to the slot provided (2), this is highlighted in the detailed view (A).
- Press down on the option module until it clicks into place.

#### Installing the second option module

- Move the option module in direction shown (3).
- Align and insert the option module tab in to the slot provided on the already installed option module (4), this is highlighted in the detailed view (B).
- Press down on the option module until it clicks into place. Image (5) shows two option modules fully installed.

#### Installing the third option module

- Repeat the above process.

The drive has the facility for all three option module slots to be used at the same time, image (6) shows the three option modules installed.

**Figure 3-2 Removal of an option module**

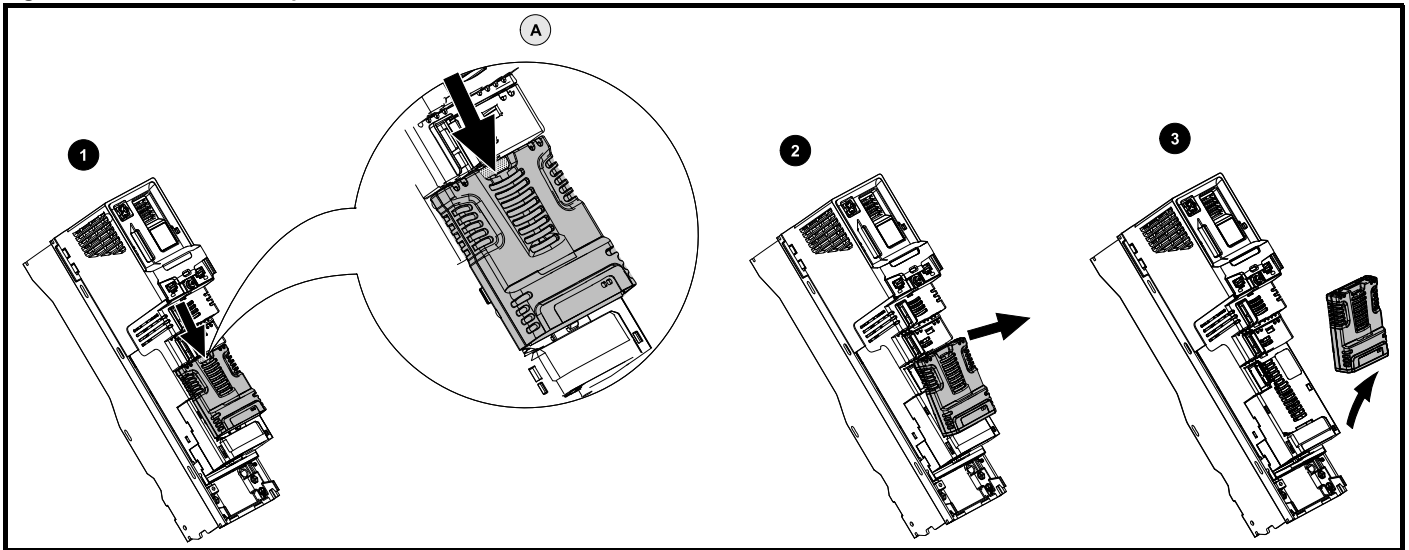

- Press down on the tab (1) to release the option module from the drive housing, the tab is highlighted in the detailed view (A).
- Tilt the option module towards you as shown (2).
- Totally remove the option module in direction shown (3).

**Figure 3-3 Installation and removal of the KI-Keypad**

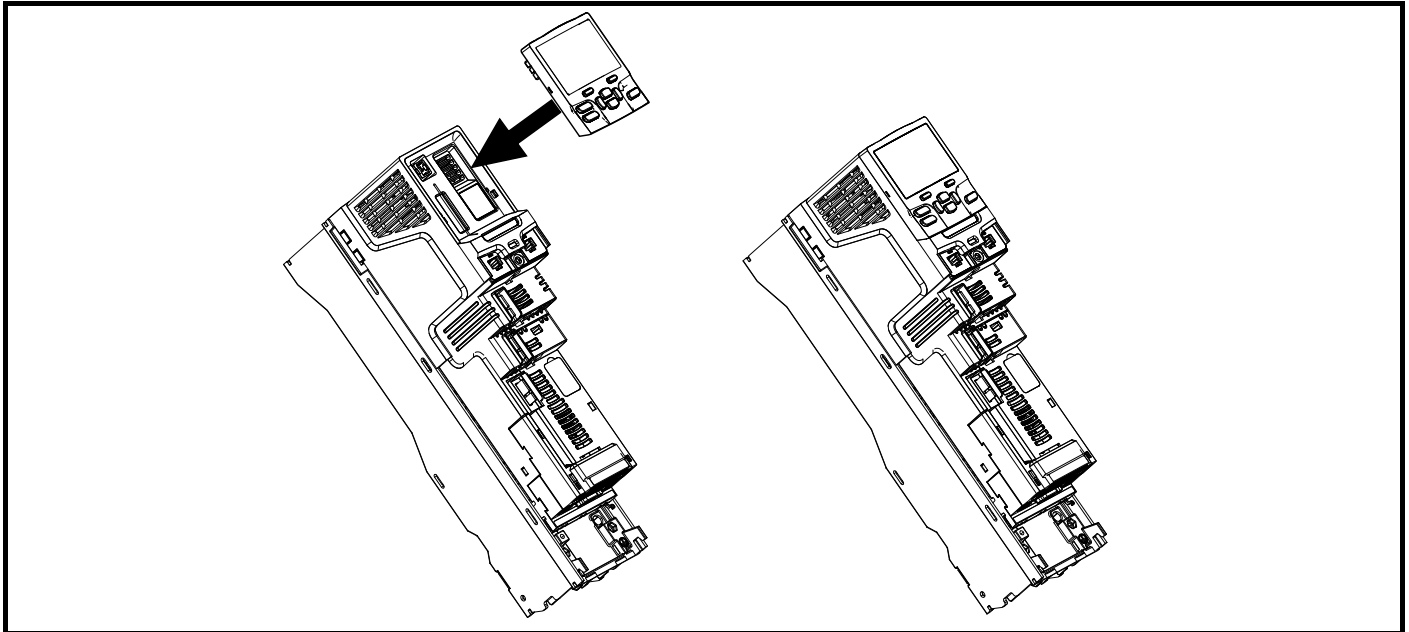

To install, align the keypad and press gently in the direction shown until it clicks into position.

To remove, reverse the installation instructions.

**NOTE**

The keypad can be installed / removed while the drive is powered up and running a motor, providing that the drive is not operating in keypad mode.

### 3.1.1 Real time clock battery replacement

Those keypads which have the real time clock feature contain a battery to ensure the clock works when the drive is powered down. The battery has a long life time but if the battery needs to be replaced or removed, follow the instructions below.

Low battery voltage is indicated by  low battery symbol on the keypad display.

**Figure 3-4 KI-Keypad RTC (rear view)**

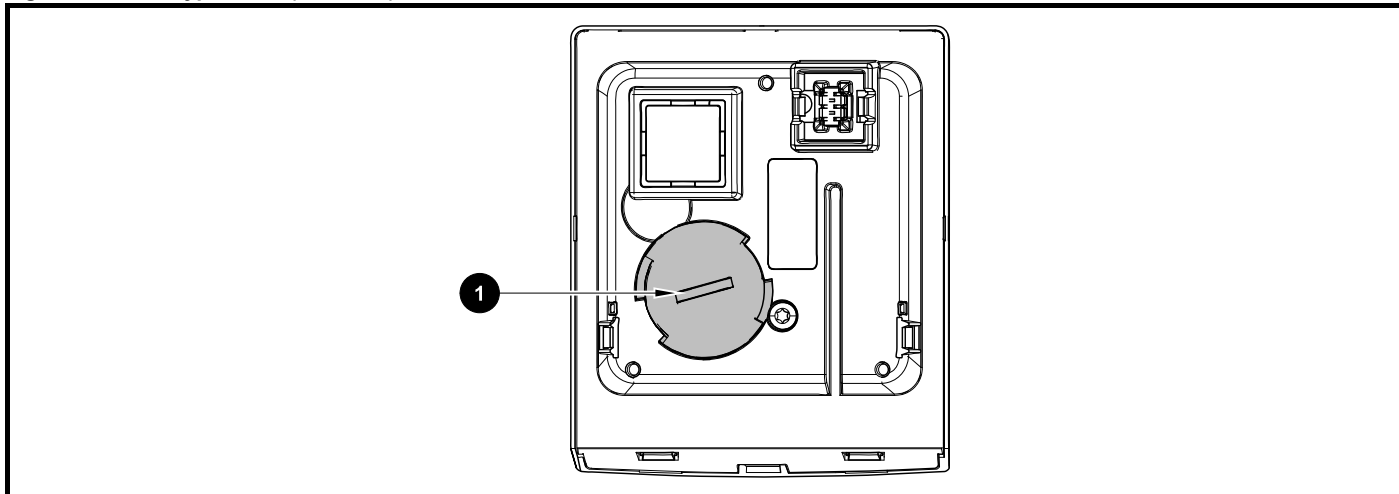

Figure 3-4 above illustrates the rear view of the KI-Keypad RTC.

1. To remove the battery cover insert a flat head screwdriver into the slot as shown (1), push and turn anti-clockwise until the battery cover is released.
2. Replace the battery (the battery type is: CR2032).
3. Reverse point 1 above to replace battery cover.

**NOTE**

Ensure the battery is disposed of correctly.

## 4 Electrical installation

### 4.1 24 Vdc supply

The 24 Vdc supply connected to control terminals 1 & 2 provides the following functions:

- It can be used to supplement the drive's own internal 24 V supply when multiple option modules are being used and the current drawn by these module is greater than the drive can supply.
- It can be used as a back-up power supply to keep the control circuits of the drive powered up when the line power supply is removed. This allows any fieldbus modules, application modules, encoders or serial communications to continue to operate.
- It can be used to commission the drive when the line power supply is not available, as the display operates correctly. However, the drive will be in the Under voltage state unless either line power supply or low voltage DC operation is enabled, therefore diagnostics may not be possible. (Power down save parameters are not saved when using the 24 V back-up power supply input).
- If the DC bus voltage is too low to run the main SMPS in the drive, then the 24 V supply can be used to supply all the low voltage power requirements of the drive. *Low Under Voltage Threshold Select* (06.067) must also be enabled for this to happen.

#### NOTE

On size 6 and larger, the power 24 Vdc supply (terminals 51, 52) must be connected to enable the 24 Vdc supply to be used as a backup supply, when the line power supply is removed. If the power 24 Vdc supply is not connected none of the above mentioned functions can be used, "Waiting For Power System" will be displayed on the keypad and no drive operations are possible. The location of the power 24 Vdc can be identified from Figure 4-1 *Location of the 24 Vdc power supply connection on size 6* on page 21.

**Table 4-1 24 Vdc Supply connections**

Function	Sizes 3-5	Sizes 6-11
Supplement the drive's internal supply	Terminal 1, 2	Terminal 1, 2
Back-up supply for the control circuit	Terminal 1, 2	Terminal 51, 52

The working voltage range of the control 24 V power supply is as follows:

<b>1</b>	<b>0V common</b>
<b>2</b>	<b>+24 Vdc</b>
Nominal operating voltage	24.0 Vdc
Minimum continuous operating voltage	19.2 V
Maximum continuous operating voltage	28.0 V
Minimum start up voltage	21.6 V
Maximum power supply requirement at 24 V	40 W
Recommended fuse	3 A, 50 Vdc

Minimum and maximum voltage values include ripple and noise. Ripple and noise values must not exceed 5 %.

The working range of the 24 V power supply is as follows:

<b>51</b>	<b>0V common</b>
<b>52</b>	<b>+24 Vdc</b>
<b>Size 6</b>	
Nominal operating voltage	24.0 Vdc
Minimum continuous operating voltage	18.6 Vdc
Maximum continuous operating voltage	28.0 Vdc
Minimum startup voltage	18.4 Vdc
Maximum power supply requirement	40 W
Recommended fuse	4 A @ 50 Vdc
<b>Size 7 to 11</b>	
Nominal operating voltage	24.0 Vdc
Minimum continuous operating voltage	19.2 Vdc
Maximum continuous operating voltage	30 Vdc (IEC), 26 Vdc (UL)
Minimum startup voltage	21.6 Vdc
Maximum power supply requirement	60 W
Recommended fuse	4 A @ 50 Vdc

**Figure 4-1 Location of the 24 Vdc power supply connection on size 6**

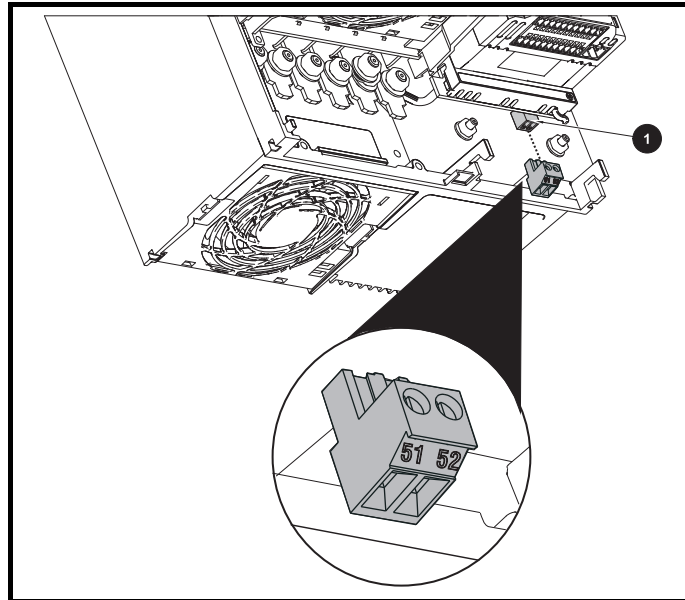

1. 24 Vdc power supply connection

**Figure 4-2 Location of the 24 Vdc power supply connection on size 7**

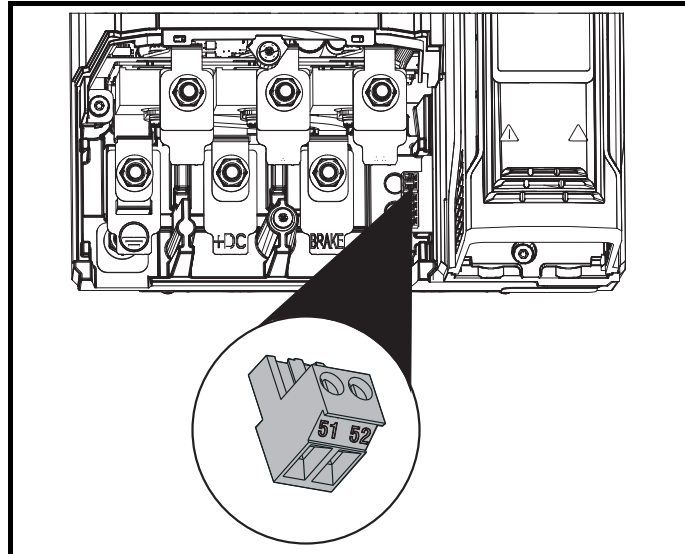

**Figure 4-3** Location of the 24 Vdc power supply connection on size 8 to 11

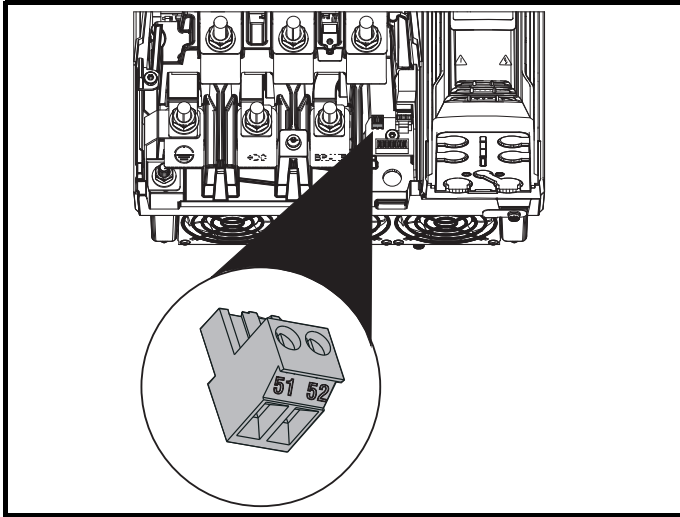

## 4.2 Communication connections

The drive offers a 2 wire EIA 485 interface. This enables the drive set-up, operation and monitoring to be carried out with a PC or controller if required.

**Figure 4-4** Location of the comms connectors

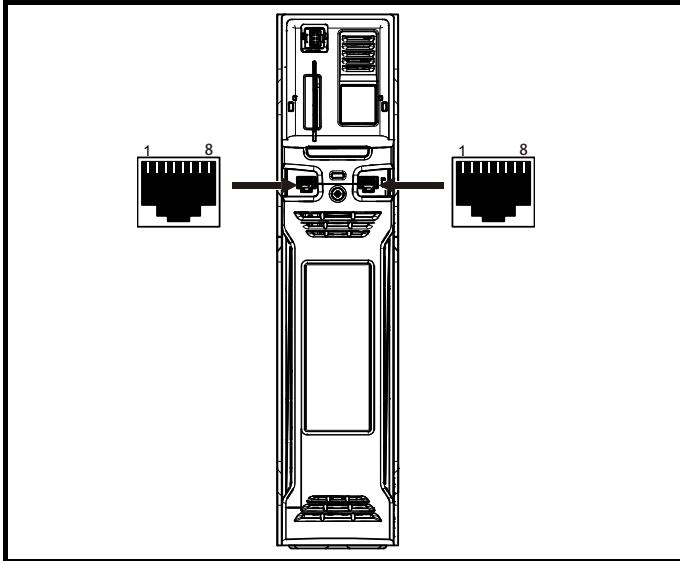

The EIA 485 interface provides two parallel RJ45 connectors, these are provided allowing easy daisy chaining. The drive only supports Modbus RTU protocol. See Table 4-2 for the connection details.

### NOTE

Standard Ethernet cables are not recommended for use when connecting drives on a EIA 485 network as they do not have the correct twisted pairs for the pinout of the serial comms port.



If an Ethernet network adaptor is inadvertently connected to a Unidrive M600 drive, a low impedance load across the EIA 485 24V is applied. If this is connected for a significant period of time, it can introduce the potential risk of damage.

**Table 4-2** Serial communication port pin-outs

Pin	Function
1	120 Ω Termination resistor
2	RX TX
3	Isolated 0 V
4	+24 V (100 mA)
5	Isolated 0 V
6	TX enable
7	RX\ TX\
8	RX\ TX\ (if termination resistors are required, link to pin 1)
Shell	Isolated 0 V

Minimum number of connections are 2, 3, 7 and shield.

### 4.2.1 Isolation of the EIA 485 serial communications port

The serial PC communications port is double insulated and meets the requirements for SELV in EN 50178:1998.



In order to meet the requirements for SELV in IEC60950 (IT equipment) it is necessary for the control computer to be grounded. Alternatively, when a lap-top or similar device is used which has no provision for grounding, an isolation device must be incorporated in the communications lead.

An isolated serial communications lead has been designed to connect the drive to IT equipment (such as laptop computers), and is available from the supplier of the drive. See below for details:

**Table 4-3** Isolated serial comms lead details

Part number	Description
4500-0096	CT USB Comms cable

The "isolated serial communications" lead has reinforced insulation as defined in IEC60950 for altitudes up to 3,000 m.

### 4.2.2 Communication networks and cabling

Any isolated signal circuit has the capability to become live through accidental contact with other conductors; as such they should always be double-insulated from live parts. The routing of network and signal wires should be done so as to avoid close proximity to mains voltage cabling.

### 4.3 Control connections

#### 4.3.1 General

Table 4-4 The control connections consist of:

Function	Qty	Control parameters available	Terminal number
Differential analog input	1	Mode, offset, invert, scaling	5, 6
Single ended analog input	2	Mode, offset, invert, scaling, destination	7, 8
Analog output	2	Source, scaling,	9, 10
Digital input	3	Destination, invert, logic select	27, 28, 29
Digital input / output	3	Input / output mode select, destination / source, invert, logic select	24, 25, 26
Relay	1	Source, invert	41, 42
Drive enable (Safe Torque Off)	1		31
+10 V User output	1		4
+24 V User output	1	Source, invert	22
0V common	6		1, 3, 11, 21, 23, 30
+24V External input	1	Destination, invert	2

**Key:**

Destination parameter:	Indicates the parameter which is being controlled by the terminal / function
Source parameter:	Indicates the parameter being output by the terminal
Mode parameter:	Analog - indicates the mode of operation of the terminal, i.e. voltage 0-10 V, current 4-20 mA etc. Digital - indicates the mode of operation of the terminal, i.e. positive / negative logic (the Drive Enable terminal is fixed in positive logic), open collector.

All analog terminal functions can be programmed in menu 7.  
All digital terminal functions (including the relay) can be programmed in menu 8.



**WARNING**

The control circuits are isolated from the power circuits in the drive by basic insulation (single insulation) only. The installer must ensure that the external control circuits are insulated from human contact by at least one layer of insulation (supplementary insulation) rated for use at the AC supply voltage.



**WARNING**

If the control circuits are to be connected to other circuits classified as Safety Extra Low Voltage (SELV) (e.g. to a personal computer), an additional isolating barrier must be included in order to maintain the SELV classification.



**CAUTION**

If any of the digital inputs (including the drive enable input) are connected in parallel with an inductive load (i.e. contactor or motor brake) then suitable suppression (i.e. diode or varistor) should be used on the coil of the load. If no suppression is used then over voltage spikes can cause damage to the digital inputs and outputs on the drive.



**CAUTION**

Ensure the logic sense is correct for the control circuit to be used. Incorrect logic sense could cause the motor to be started unexpectedly.  
Positive logic is the default state for the drive.

**NOTE**

Any signal cables which are carried inside the motor cable (i.e. motor thermistor, motor brake) will pick up large pulse currents via the cable capacitance. The shield of these signal cables must be connected to

ground close to the point of exit of the motor cable, to avoid this noise current spreading through the control system.

**NOTE**

The Safe Torque Off drive enable terminal is a positive logic input only. It is not affected by the setting of *Input Logic Polarity* (08.029).

**NOTE**

The common 0 V from analog signals should, wherever possible, not be connected to the same 0 V terminal as the common 0 V from digital signals. Terminals 3 and 11 should be used for connecting the 0V common of analog signals and terminals 21, 23 and 30 for digital signals. This is to prevent small voltage drops in the terminal connections causing inaccuracies in the analog signals.

**NOTE**

A two wire motor thermistor can be connected to analog input 3 by connecting the thermistor between terminal 8 and any 0 V common terminal. It is also possible to connect a 4-wire thermistor to analog input 3 as shown below. Pr **07.015** and Pr **07.046** need to be set-up for the thermistor type required.

Figure 4-5 Connection of 4-wire thermistor

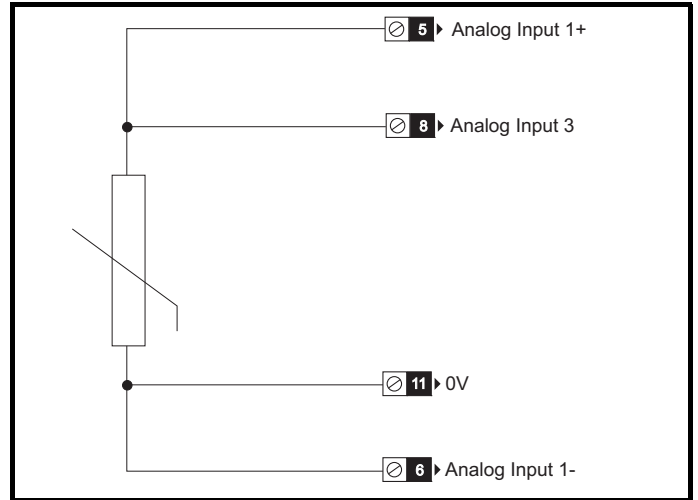
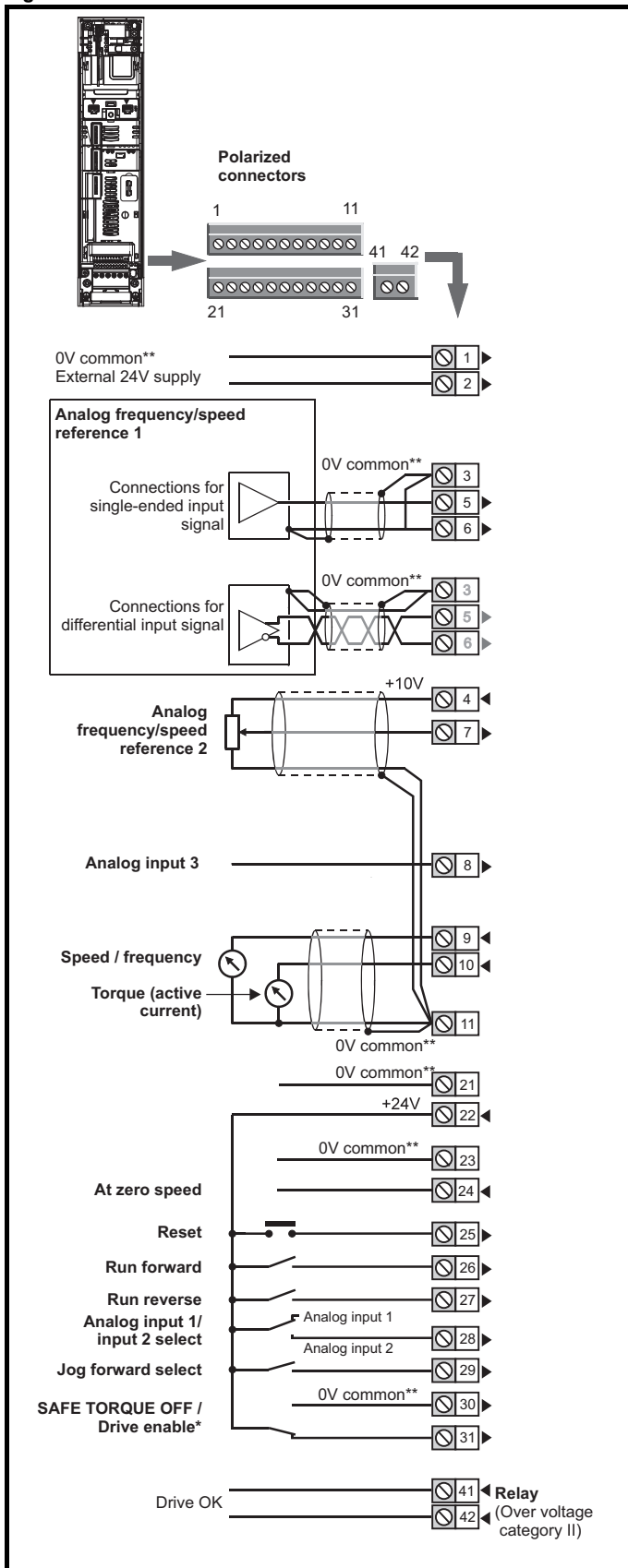

Figure 4-6 Default terminal functions



\*The Safe Torque Off / Drive enable terminal is a positive logic input only.

\*\* 0V common is connected to ground internally in size 9 to 11 modular drives.

### 4.3.2 Control terminal specification

1 0V common	
Function	Common connection for all external devices

2 +24V external input	
Function	To supply the control circuit without providing a supply to the power stage
Programmability	Can be switched on or off to act as a digital input by setting the source Pr 08.063 and input invert Pr 08.053
Nominal voltage	+24.0 Vdc
Minimum continuous operating voltage	+19.2 Vdc
Maximum continuous operating voltage	+28.0 Vdc
Minimum start-up voltage	21.6 Vdc
Recommended power supply	40 W 24 Vdc nominal
Recommended fuse	3 A, 50 Vdc

3 0V common	
Function	Common connection for all external devices

4 +10V user output	
Function	Supply for external analog devices
Voltage	10.2 V nominal
Voltage tolerance	±1 %
Nominal output current	10 mA
Protection	Current limit and trip @ 30 mA

<b>4</b>	<b>Precision reference Analog input 1</b>
<b>5</b>	<b>Non-inverting input</b>
<b>6</b>	<b>Inverting input</b>
<b>Default function</b>	<b>Frequency/speed reference</b>
Type of input	Bipolar differential analog voltage or current, thermistor input
Mode controlled by:	Pr <b>07.007</b>
Operating in Voltage mode	
Full scale voltage range	±10 V ±2 %
Maximum offset	±10 mV
Absolute maximum voltage range	±36 V relative to 0 V
Working common mode voltage range	±13 V relative to 0 V
Input resistance	≥100 kΩ
Monotonic	Yes (including 0 V)
Dead band	None (including 0 V)
Jumps	None (including 0 V)
Maximum offset	20 mV
Maximum non linearity	0.3% of input
Maximum gain asymmetry	0.5 %
Input filter bandwidth single pole	~3 kHz
Operating in current mode	
Current ranges	0 to 20 mA ±5 %, 20 to 0 mA ±5 %, 4 to 20 mA ±5 %, 20 to 4 mA ±5 %
Maximum offset	250 μA
Absolute maximum voltage (reverse biased)	±36 V relative to 0 V
Equivalent input resistance	≤300 Ω
Absolute maximum current	±30 mA
Operating in thermistor input mode (in conjunction with analog input 3)	
Internal pull-up voltage	2.5 V
Trip threshold resistance	User defined in Pr <b>07.048</b>
Short-circuit detection resistance	50 Ω ± 40 %
Common to all modes	
Resolution	12 bits (11 bits plus sign)
Sample / update period	250 μs with destinations Pr <b>01.036</b> , Pr <b>01.037</b> , Pr <b>03.022</b> or Pr <b>04.008</b> in RFC-A and RFC-S modes. 4 ms for open loop mode and all other destinations in RFC-A or RFC-S modes.

<b>7</b>	<b>Analog input 2</b>
<b>Default function</b>	<b>Frequency / speed reference</b>
Type of input	Bipolar single-ended analog voltage or unipolar current
Mode controlled by...	Pr <b>07.011</b>
<b>Operating in voltage mode</b>	
Full scale voltage range	±10 V ±2 %
Maximum offset	±10 mV
Absolute maximum voltage range	±36 V relative to 0 V
Input resistance	≥100 k Ω
<b>Operating in current mode</b>	
Current ranges	0 to 20 mA ±5 %, 20 to 0 mA ±5 %, 4 to 20 mA ±5 %, 20 to 4 mA ±5 %
Maximum offset	250 μA
Absolute maximum voltage (reverse bias)	±36 V relative to 0V
Absolute maximum current	±30 mA
Equivalent input resistance	≤ 300 Ω
<b>Common to all modes</b>	
Resolution	12 bits (11 bits plus sign)
Sample / update	250 μs with destinations Pr <b>01.036</b> , Pr <b>01.037</b> or Pr <b>03.022</b> , Pr <b>04.008</b> in RFC-A or RFC-S. 4ms for open loop mode and all other destinations in RFC-A or RFC-S mode.

<b>8</b>	<b>Analog input 3</b>
<b>Default function</b>	<b>Voltage input</b>
Type of input	Bipolar single-ended analog voltage, or thermistor input
Mode controlled by...	Pr <b>07.015</b>
<b>Operating in Voltage mode (default)</b>	
Voltage range	±10 V ±2 %
Maximum offset	±10 mV
Absolute maximum voltage range	±36 V relative to 0 V
Input resistance	≥100 k Ω
<b>Operating in thermistor input mode</b>	
Supported thermistor types	Din 44082, KTY 84, PT100, PT 1000, PT 2000, 2.0mA
Internal pull-up voltage	2.5 V
Trip threshold resistance	User defined in Pr <b>07.048</b>
Reset resistance	User defined in Pr <b>07.048</b>
Short-circuit detection resistance	50 Ω ± 40 %
<b>Common to all modes</b>	
Resolution	12 bits (11 bits plus sign)
Sample / update period	4 ms

<b>9</b>	<b>Analog output 1</b>
<b>10</b>	<b>Analog output 2</b>
<b>Terminal 9 default function</b>	<b>OL&gt; Motor FREQUENCY output signal</b>
	<b>RFC&gt; SPEED output signal</b>
<b>Terminal 10 default function</b>	<b>Motor active current</b>
Type of output	Bipolar single-ended analog voltage
<b>Operating in Voltage mode (default)</b>	
Voltage range	±10 V ±5 %
Maximum offset	±120 mV
Maximum output current	±20 mA
Load resistance	≥1 k Ω
Protection	20 mA max. Short circuit protection
<b>Common to all modes</b>	
Resolution	10-bit
Sample / update period	250 μs (output will only change at update the rate of the source parameter if slower)

<b>11</b>	<b>0V common</b>
<b>Function</b>	<b>Common connection for all external devices</b>

<b>21</b>	<b>0V common</b>
<b>Function</b>	<b>Common connection for all external devices</b>

<b>22</b>	<b>+24 V user output (selectable)</b>
<b>Terminal 22 default function</b>	<b>+24 V user output</b>
Programmability	Can be switched on or off to act as a fourth digital output (positive logic only) by setting the source Pr <b>08.028</b> and source invert Pr <b>08.018</b>
Nominal output current	100 mA combined with DIO3
Maximum output current	100 mA 200 mA (total including all Digital I/O)
Protection	Current limit and trip
Sample / update period	2 ms when configured as an output (output will only change at the update rate of the source parameter if slower)

<b>23</b>	<b>0V common</b>
<b>Function</b>	<b>Common connection for all external devices</b>

<b>24</b>	<b>Digital I/O 1</b>
<b>25</b>	<b>Digital I/O 2</b>
<b>26</b>	<b>Digital I/O 3</b>
<b>Terminal 24 default function</b>	<b>AT ZERO SPEED output</b>
<b>Terminal 25 default function</b>	<b>DRIVE RESET input</b>
<b>Terminal 26 default function</b>	<b>RUN FORWARD input</b>
Type	Positive or negative logic digital inputs, positive logic voltage source outputs
Input / output mode controlled by...	Pr <b>08.031</b> , Pr <b>08.032</b> and Pr <b>08.033</b>
<b>Operating as an input</b>	
Logic mode controlled by...	Pr <b>08.029</b>
Absolute maximum applied voltage range	-3 V to +30 V
Impedance	>2 mA @15 V (IEC 61131-2, type 1, 6.6 k Ω)
Input thresholds	10 V ±0.8 V (IEC 61131-2, type 1)
<b>Operating as an output</b>	
Nominal maximum output current	100 mA (DIO1 & 2 combined) 100 mA (DIO3 & 24 V User Output Combined)
Maximum output current	100 mA 200 mA (total including all Digital I/O)
<b>Common to all modes</b>	
Voltage range	0 V to +24 V
Sample / Update period	2 ms (output will only change at the update rate of the source parameter)

<b>27</b>	<b>Digital Input 4</b>
<b>28</b>	<b>Digital Input 5</b>
<b>Terminal 27 default function</b>	<b>RUN REVERSE input</b>
<b>Terminal 28 default function</b>	<b>Analog INPUT 1 / INPUT 2 select</b>
Type	Negative or positive logic digital inputs
Logic mode controlled by...	Pr <b>08.029</b>
Voltage range	0 V to +24 V
Absolute maximum applied voltage range	-3 V to +30 V
Impedance	>2 mA @15 V (IEC 61131-2, type 1, 6.6 k Ω)
Input thresholds	10 V ±0.8 V (IEC 61131-2, type 1)
Sample / Update period	250 μs when configured as an input with destinations Pr <b>06.035</b> or Pr <b>06.036</b> . 600 μs when configured as an input with destination Pr <b>06.029</b> . 2 ms in all other cases.

<b>29</b>	<b>Digital Input 6</b>
<b>Terminal 29 default function</b>	<b>JOG SELECT input</b>
Type	Negative or positive logic digital inputs
Logic mode controlled by...	Pr <b>08.029</b>
Voltage range	0 V to +24 V
Absolute maximum applied voltage range	-3 V to +30 V
Impedance	>2 mA @15 V (IEC 61131-2, type 1, 6.6 k Ω)
Input thresholds	10 V ±0.8 V (IEC 61131-2, type 1)
Sample / Update period	250 μs when configured as an input with destinations Pr <b>06.035</b> or Pr <b>06.036</b> . 2 ms in all other cases.

<b>30</b>	<b>0V common</b>
<b>Function</b>	<b>Common connection for all external devices</b>

<b>31</b>	<b>Safe Torque Off function (drive enable)</b>
Type	Positive logic only digital input
Voltage range	0 V to +24 V
Absolute maximum applied voltage	30 V
Logic Threshold	10 V ± 5 V
Low state maximum voltage for disable to SIL3 and PL e	5 V
Impedance	>4 mA @15 V (IEC 61131-2, type 1, 3.3 k Ω)
Low state maximum current for disable to SIL3 and PL e	0.5 mA
Response time	Nominal: 8 ms Maximum: 20 ms
<p>The Safe Torque Off function may be used in a safety-related application in preventing the drive from generating torque in the motor to a high level of integrity. The system designer is responsible for ensuring that the complete system is safe and designed correctly according to the relevant safety standards. If the Safe Torque Off function is not required, this terminal is used for enabling the drive.</p>	

Refer to section 4.4 for further information.

<b>41</b>	<b>Relay contacts</b>
<b>42</b>	
<b>Default function</b>	<b>Drive healthy indicator</b>
Contact voltage rating	240 Vac, Installation over-voltage category II
Contact maximum current rating	2 A AC 240 V 4 A DC 30 V resistive load 0.5 A DC 30 V inductive load (L/R = 40 ms)
Contact minimum recommended rating	12 V 100 mA
Contact type	Normally open
Default contact condition	Closed when power applied and drive healthy
Update period	4 ms

<b>51</b>	<b>0V common</b>
<b>52</b>	<b>+24 Vdc</b>
<b>Size 6</b>	
Nominal operating voltage	24.0 Vdc
Minimum continuous operating voltage	18.6 Vdc
Maximum continuous operating voltage	28.0 Vdc
Minimum startup voltage	18.4 Vdc
Maximum power supply requirement	40 W
Recommended fuse	4 A @ 50 Vdc
<b>Size 7 to 11</b>	
Nominal operating voltage	24.0 Vdc
Minimum continuous operating voltage	19.2 Vdc
Maximum continuous operating voltage	30 Vdc (IEC), 26 Vdc (UL)
Minimum startup voltage	21.6 Vdc
Maximum power supply requirement	60 W
Recommended fuse	4 A @ 50 Vdc



To prevent the risk of a fire hazard in the event of a fault, a fuse or other over-current protection must be installed in the relay circuit.

## 4.4 Safe Torque Off (STO)

The Safe Torque Off function provides a means for preventing the drive from generating torque in the motor, with a very high level of integrity. It is suitable for incorporation into a safety system for a machine. It is also suitable for use as a conventional drive enable input.

The safety function is active when the STO input is in the logic-low state as specified in the control terminal specification. The function is defined according to EN 61800-5-2 and IEC 61800-5-2 as follows. (In these standards a drive offering safety-related functions is referred to as a PDS(SR)):

'Power that can cause rotation (or motion in the case of a linear motor) is not applied to the motor. The PDS(SR) will not provide energy to the motor which can generate torque (or force in the case of a linear motor)'

This safety function corresponds to an uncontrolled stop in accordance with stop category 0 of IEC 60204-1.

The Safe Torque Off function makes use of the special property of an inverter drive with an induction motor, which is that torque cannot be generated without the continuous correct active behaviour of the inverter circuit. All credible faults in the inverter power circuit cause a loss of torque generation.

The Safe Torque Off function is fail-safe, so when the Safe Torque Off input is disconnected the drive will not operate the motor, even if a combination of components within the drive has failed. Most component failures are revealed by the drive failing to operate. Safe Torque Off is also independent of the drive firmware. This meets the requirements of the following standards, for the prevention of operation of the motor.

### Machinery Applications

The Safe Torque Off function has been independently assessed by Notified Body, TÜV Rheinland for use as a safety component of a machine:

*Prevention of unintended motor operation: The safety function "Safe Torque Off" can be used in applications up to Cat 4. PL e according to EN ISO 13849-1, SIL 3 according to EN 61800-5-2/ EN 62061/ IEC 61508, and in lift applications according to EN 81-1 and EN81-2.*

Type examination certificate number	Date of issue	Models
01.205/5270.01/14	11-11-2014	M600

This certificate is available for download from the TÜV Rheinland website at: <http://www.tuv.com>

### Safety Parameters as verified by TÜV Rheinland:

According to IEC 61508-1 to 07 / EN 61800-5-2 / EN 62061

Type	Value	Percentage of SIL 3 allowance
Proof test interval	20 years	
High demand or a continuous mode of operation		
PFH (1/h)	$4.21 \times 10^{-11}$ 1/h	<1 %
Low demand mode of operation (not EN 61800-5-2)		
PFDavg	$3.68 \times 10^{-6}$	< 1 %

According to EN ISO 13849-1

Type	Value	Classification
Category	4	
Performance Level (PL)	e	
MTTF <sub>D</sub>	>2500 years	High
DC <sub>avg</sub>	≥99 %	High
Mission time	20 years	

### NOTE

Logic levels comply with IEC 61131-2:2007 for type 1 digital inputs rated at 24 V. Maximum level for logic low to achieve SIL3 and PL e 5 V and 0.5 mA.

### Lift (Elevator) Applications

The Safe Torque Off function has been independently assessed for use as a safety component in lift (elevator) applications by Notified Body, TÜV Nord:

*The Unidrive M drives series with Safe Torque Off (STO) function if applied according to the "Conditions of application" fulfil the safety requirements of the standards EN81-1, EN81-2, EN 81-50 and EN60664-1 and are in conformity with all relevant requirements of the Directive 95/16/EC.*

Certificate of Conformity number	Date of issue	Models
44799 13196202	04-08-2015	M600

The Safe Torque Off function can be used to eliminate electro-mechanical contactors, including special safety contactors, which would otherwise be required for safety applications.

For further information contact the supplier of the drive.

### UL Approval

The Safe Torque Off function has been independently assessed by Underwriters Laboratories (UL). The on-line certification (yellow card) reference is: FSPC.E171230.

### Safety Parameters as verified by UL:

According to IEC 61508-1 to 7

Type	Value
Safety Rating	SIL 3
SFF	> 99 %
PFH (1/h)	$4.43 \times 10^{-10}$ 1/h (<1 % of SIL 3 allowance)
HFT	1
Beta Factor	2 %
CFF	Not applicable

According to EN ISO 13849-1

Type	Value
Category	4
Performance Level (PL)	e
MTTF <sub>D</sub>	2574 years
Diagnostic coverage	High
CCF	65

### Note on response time of Safe Torque Off, and use with safety controllers with self-testing outputs:

Safe Torque Off has been designed to have a response time of greater than 1 ms so that it is compatible with safety controllers whose outputs are subject to a dynamic test with a pulse width not exceeding 1 ms.

### Note on the use of servo motors, other permanent-magnet motors, reluctance motors and salient-pole induction motors:

When the drive is disabled through Safe Torque Off, a possible (although highly unlikely) failure mode is for two power devices in the inverter circuit to conduct incorrectly.

This fault cannot produce a steady rotating torque in any AC motor. It produces no torque in a conventional induction motor with a cage rotor. If the rotor has permanent magnets and/or saliency, then a transient alignment torque may occur. The motor may briefly try to rotate by up to 180° electrical, for a permanent magnet motor, or 90° electrical, for a salient pole induction motor or reluctance motor. This possible failure mode must be allowed for in the machine design.



**WARNING**

The design of safety-related control systems must only be done by personnel with the required training and experience. The Safe Torque Off function will only ensure the safety of a machine if it is correctly incorporated into a complete safety system. The system must be subject to a risk assessment to confirm that the residual risk of an unsafe event is at an acceptable level for the application.



**WARNING**

Safe Torque Off inhibits the operation of the drive, this includes inhibiting braking. If the drive is required to provide both braking and Safe Torque Off in the same operation (e.g. for emergency stop) then a safety timer relay or similar device must be used to ensure that the drive is disabled a suitable time after braking. The braking function in the drive is provided by an electronic circuit which is not fail-safe. If braking is a safety requirement, it must be supplemented by an independent fail-safe braking mechanism.



**WARNING**

Safe Torque Off does not provide electrical isolation. The supply to the drive must be disconnected by an approved isolation device before gaining access to power connections.

With Safe Torque Off there are no single faults in the drive which can permit the motor to be driven. Therefore it is not necessary to have a second channel to interrupt the power connection, nor a fault detection circuit.

It is important to note that a single short-circuit from the Safe Torque Off input to a DC supply of > 5 V could cause the drive to be enabled. This can be excluded under EN ISO 13849-2 by the use of protected wiring. The wiring can be protected by either of the following methods:

- By placing the wiring in a segregated cable duct or other enclosure.

or

- By providing the wiring with a grounded shield in a positive-logic grounded control circuit. The shield is provided to avoid a hazard from an electrical fault. It may be grounded by any convenient method; no special EMC precautions are required.



**WARNING**

It is essential to observe the maximum permitted voltage of 5 V for a safe low (disabled) state of Safe Torque Off. The connections to the drive must be arranged so that voltage drops in the 0V wiring cannot exceed this value under any loading condition. It is strongly recommended that the Safe Torque Off circuit be provided with a dedicated 0V conductor which should be connected to terminal 30 at the drive.

#### Safe Torque Off over-ride

The drive does not provide any facility to over-ride the Safe Torque Off function, for example for maintenance purposes.

#### SISTEMA software utility

A library for use with the SISTEMA software utility providing relevant parameters for Unidrive M Safe Torque Off function and SI-Safety Module is available, please contact the supplier of the drive for further info.

## 5 Getting started

This chapter introduces the user interfaces, menu structure and security levels of the drive.

### 5.1 Understanding the display

The keypad can only be mounted on the drive.

#### 5.1.1 KI-Keypad

The KI-Keypad display consists of two rows of text. The upper row shows the drive status or the menu and parameter number currently being viewed. The lower row of the display line shows the parameter value or the specific trip type. The last two characters on the first row may display special indications. If more than one of these indications is active then the indications are prioritized as shown in Table 5-2.

When the drive is powered up the lower row will show the power up parameter defined by *Parameter Displayed At Power-Up* (11.022).

Figure 5-1 KI-Keypad

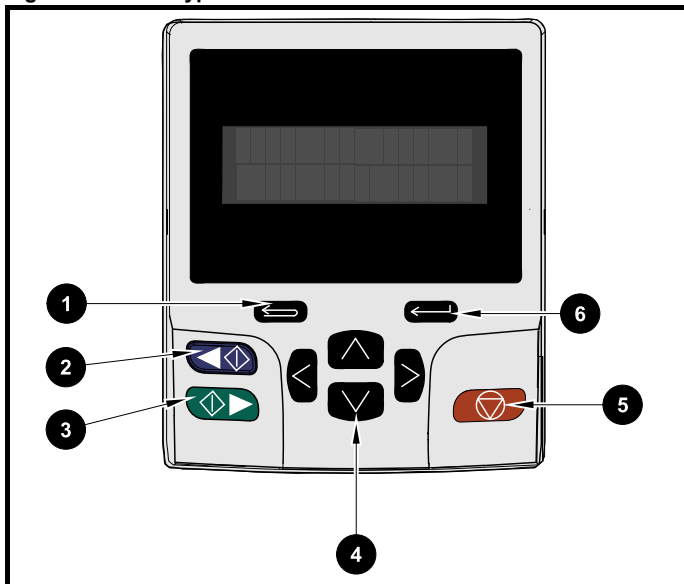

1. Escape button
2. Start reverse (Auxiliary button)
3. Start forward
4. Navigation keys (x4)
5. Stop / Reset (red) button
6. Enter button

#### NOTE







The red stop  button is also used to reset the drive.

The parameter value is correctly displayed in the lower row of the keypad display, see table below.

Table 5-1 Keypad display formats

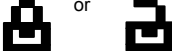
Display formats	Value
IP Address	127.000.000.000
MAC Address	01ABCDEF2345
Time	12:34:56
Date	31-12-11 or 12-31-11
Version number	01.02.02.00
Character	ABCD
32 bit number with decimal point	21474836.47
16 bit binary number	0100001011100101
Text	M600
Number	1.5 Hz

Table 5-2 Active action icon

Active action icon	Description	Row (1=top)	Priority in row
	Accessing non-volatile media card	1	1
	Alarm active	1	2
	Keypad real-time clock battery low	1	3
	Drive security active and locked or unlocked	1	4
	Motor map 2 active	2	1
	User program running	3	1
	Keypad reference active	4	1

### 5.2 Keypad operation

#### 5.2.1 Control buttons

The keypad consists of:

- Navigation Keys - Used to navigate the parameter structure and change parameter values.
- Enter / Mode button - Used to toggle between parameter edit and view mode.
- Escape / Exit button - Used to exit from parameter edit or view mode. In parameter edit mode, if parameter values are edited and the exit button pressed the parameter value will be restored to the value it had on entry to edit mode.
- Start forward button - Use to provide a 'Run' command if keypad mode is selected.
- Start reverse button - Used to control the drive if keypad mode is selected and the reverse button is activated. If *Enable Auxiliary Key* (06.013) = 1, then the keypad reference is toggled between run forward and run reverse each time the button is pressed. If *Enable Auxiliary Key* (06.013) = 2, then the button functions as a run reverse key.
- Stop / Reset button - Used to reset the drive. In keypad mode can be used for 'Stop'.

Figure 5-2 Display modes

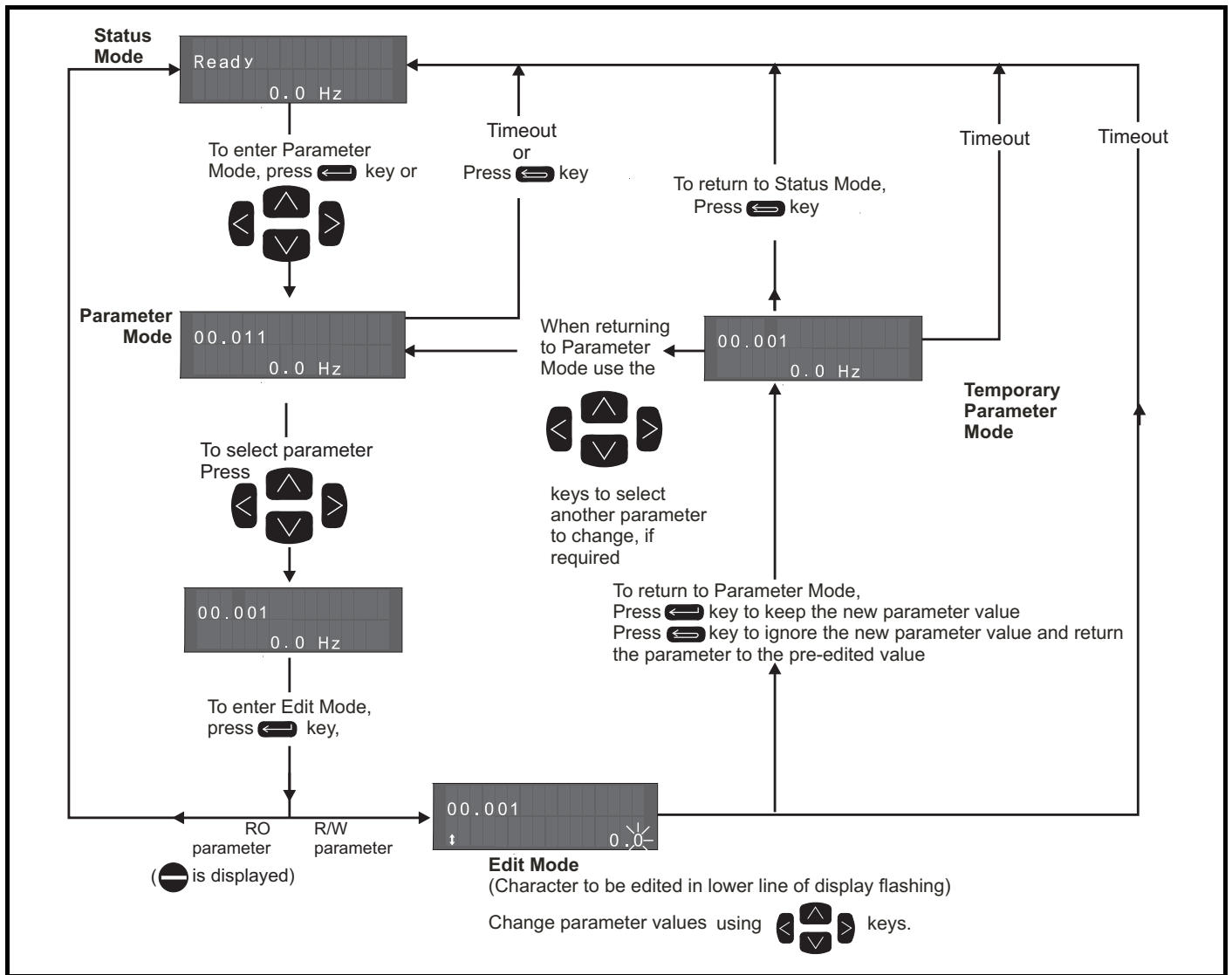

**NOTE**

The navigation keys can only be used to move between menus if Pr 00.049 has been set to show 'All Menus'. Refer to section 5.9 *Parameter access level and security* on page 36.

**5.2.2 Quick access mode**

The quick access mode allows direct access to any parameter without scrolling through menus and parameters.

To enter the quick access mode, press and hold the Enter button on the keypad while in 'parameter mode'.

Figure 5-3 Quick access mode



**5.2.3 Keypad shortcuts**

In 'parameter mode':

- If the up and down keypad buttons are pressed together, then the keypad display will jump to the start of the parameter menu being viewed, i.e. Pr 05.005 being viewed, when the above buttons pressed together will jump to Pr 05.000.
- If the left and right keypad buttons are pressed together, then the keypad display will jump to the last viewed parameter in Menu 0.

In 'parameter edit mode':

- If the up and down keypad buttons are pressed together, then the parameter value of the parameter being edited will be set to 0.
- If the left and right keypad buttons are pressed together, the least significant digit (furthest right) will be selected on the keypad display for editing.

Figure 5-4 Mode examples

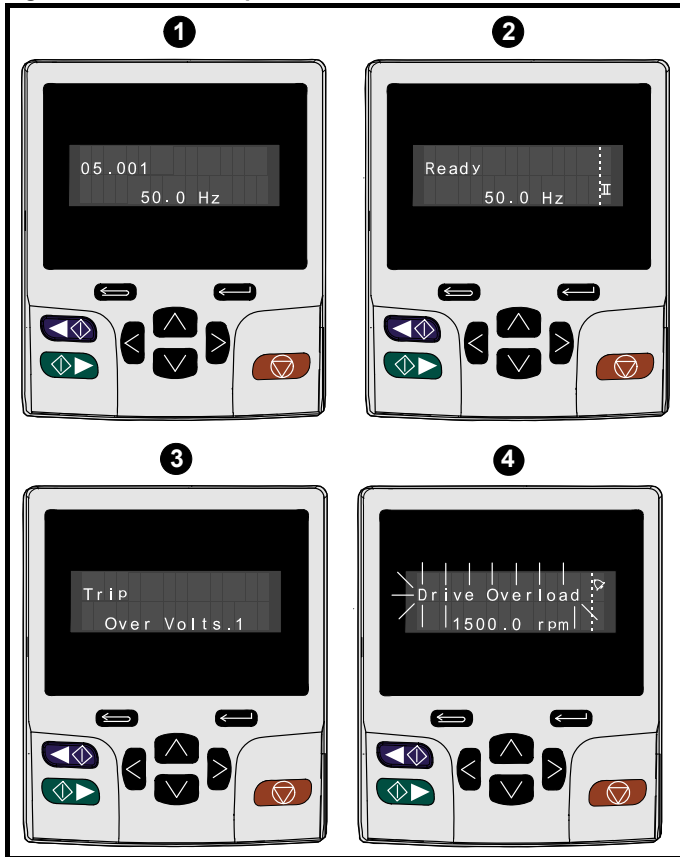

1. Parameter view mode: Read write or Read only

2. Status mode: Drive healthy status

If the drive is ok and the parameters are not being edited or viewed, the upper row of the display will show one of the following:

- 'Inhibit', 'Ready' or 'Run'.

3. Status mode: Trip status

When the drive is in trip condition, the upper row of the display will indicate that the drive has tripped and the lower row of the display will show the trip code. For further information regarding trip codes, refer to Table 11-3 *Trip indications* on page 185.

4. Status mode: Alarm status

During an 'alarm' condition the upper row of the display flashes between the drive status (Inhibit, Ready or Run, depending on what is displayed) and the alarm.

**WARNING** Do not change parameter values without careful consideration; incorrect values may cause damage or a safety hazard.

**NOTE**

When changing the values of parameters, make a note of the new values in case they need to be entered again.

**NOTE**

For new parameter-values to apply after the line power supply to the drive is interrupted, new values must be saved. Refer to section 5.7 *Saving parameters* on page 35.

## 5.3 Menu structure

The drive parameter structure consists of menus and parameters.

The drive initially powers up so that only Menu 0 can be viewed. The up and down arrow buttons are used to navigate between parameters and once Pr 00.049 has been set to 'All Menus' the left and right buttons are used to navigate between menus. For further information, refer to section 5.9 *Parameter access level and security* on page 36

Figure 5-5 Parameter navigation

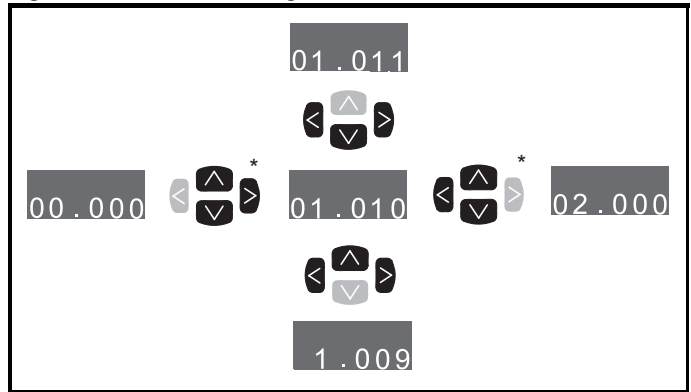

\* Can only be used to move between menus if all menus have been enabled (Pr 00.049). Refer to section 5.9 *Parameter access level and security* on page 36.

The menus and parameters roll over in both directions.

i.e. if the last parameter is displayed, a further press will cause the display to rollover and show the first parameter.

When changing between menus the drive remembers which parameter was last viewed in a particular menu and thus displays that parameter.

Figure 5-6 Menu structure

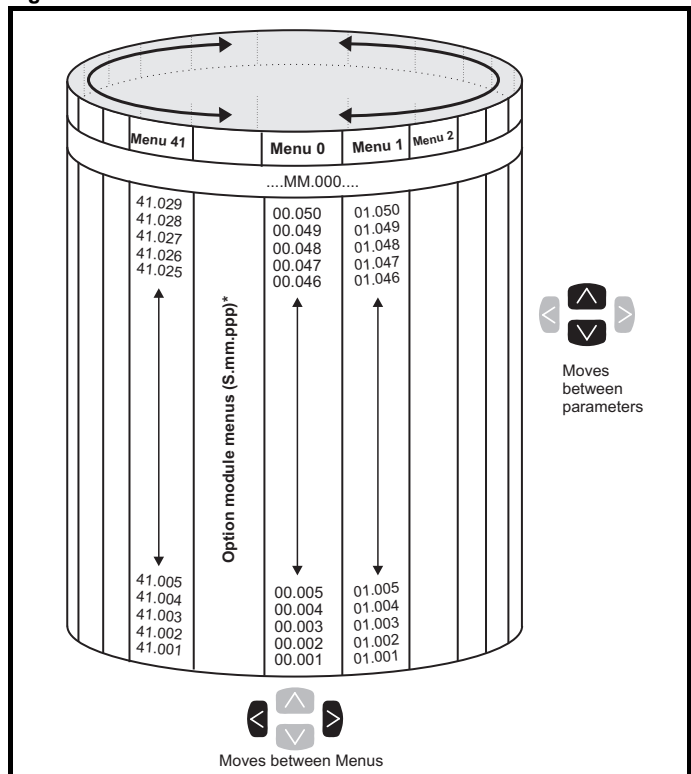

\* The option module menus (S.mm.ppp) are only displayed if option modules are installed. Where S signifies the option module slot number and the mm.ppp signifies the menu and the parameter number of the option module's internal menus and parameter.

## 5.4 Menu 0

Menu 0 is used to bring together various commonly used parameters for basic easy set up of the drive. The parameters displayed in Menu 0 can be configured in Menu 22.

Appropriate parameters are copied from the advanced menus into Menu 0 and thus exist in both locations.

For further information, refer to Chapter 6 *Basic parameters* on page 38.

**Figure 5-7 Menu 0 copying**

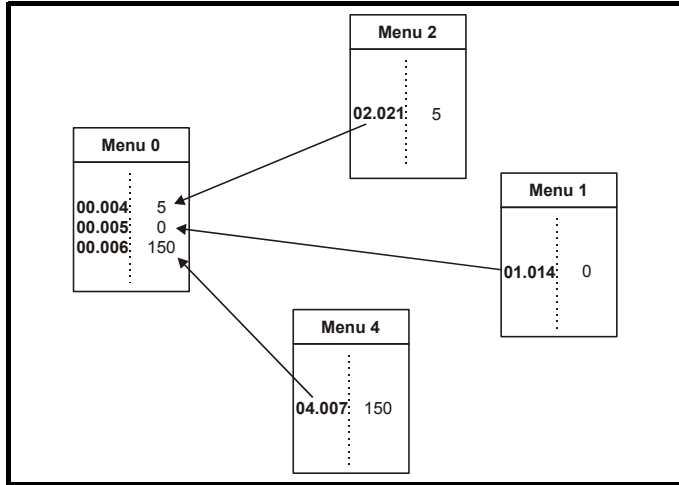

## 5.5 Advanced menus

The advanced menus consist of groups or parameters appropriate to a specific function or feature of the drive. Menus 0 to 41 can be viewed on the KI-Keypad.

The option module menus (S.mm.ppp) are only displayed if option modules are installed. Where S signifies the option module slot number and the mm.ppp signifies the menu and parameter number of the option module's internal menus and parameter.



**Table 5-3 Advanced menu descriptions**

Menu	Description
0	Commonly used basic set up parameters for quick / easy programming
1	Frequency / Speed reference
2	Ramps
3	Speed feedback and speed control
4	Torque and current control
5	Motor control
6	Sequencer and clock
7	Analog I/O, Temperature monitoring
8	Digital I/O
9	Programmable logic, motorized pot, binary sum, timers and scope
10	Status and trips
11	Drive set-up and identification, serial communications
12	Threshold detectors and variable selectors
13	Standard motion control
14	User PID controller
15	Option module slot 1 set-up menu
16	Option module slot 2 set-up menu
17	Option module slot 3 set-up menu
18	General option module application menu 1
19	General option module application menu 2
20	General option module application menu 3
21	Second motor parameters
22	Menu 0 set-up
23	Not allocated
28	Reserved menu
29	Reserved menu
30	Onboard user programming application menu
Slot 1	Slot 1 option menus*
Slot 2	Slot 2 option menus*
Slot 3	Slot 3 option menus*

\*Only displayed when the option modules are installed.

### 5.5.1 KI-Keypad set-up menu

To enter the keypad set-up menu press and hold the escape  button on the keypad from status mode. All the keypad parameters are saved to the keypad non-volatile memory when exiting from the keypad set-up menu.

To exit from the keypad set-up menu press the escape  or  or  button. Below are the keypad set-up parameters.

**Table 5-4 KI-Keypad set-up parameters**

Parameters		Range	Type
Keypad.00	Language*	Classic English (0) English (1) German (2) French (3) Italian (4) Spanish (5) Chinese (6)	RW
Keypad.01	Show Units	Off (0), On (1)	RW
Keypad.02	Backlight Level	0 to 100 %	RW
Keypad.03	Keypad Date	01.01.10 to 31.12.99	RO
Keypad.04	Keypad Time	00:00:00 to 23:59:59	RO
Keypad.05	Show Raw Text Parameter Values	Off (0), On (1)	RW
Keypad.06	Software Version	00.00.00.00 to 99.99.99.99	RO
Keypad.07	Language version	00.00.00.00 to 99.99.99.99	RO
Keypad.08	Font version	0 to 1000	RO
Keypad.09	Show menu names	Off or on	RW

**NOTE**

It is not possible to access the keypad parameters via any communications channel.

\* The languages available will depend on the keypad software version.

### 5.5.2 Display messages

The following tables indicate the various possible mnemonics which can be displayed by the drive and their meaning.

**Table 5-5 Status indications**

Upper row string	Description	Drive output stage
<b>Inhibit</b>	The drive is inhibited and cannot be run. The Safe Torque Off signal is not applied to Safe Torque Off terminals or Pr <b>06.015</b> is set to 0. The other conditions that can prevent the drive from enabling are shown as bits in <i>Enable Conditions</i> (06.010)	Disabled
<b>Ready</b>	The drive is ready to run. The drive enable is active, but the drive inverter is not active because the final drive run is not active	Disabled
<b>Stop</b>	The drive is stopped / holding zero speed	Enabled
<b>Run</b>	The drive is active and running	Enabled
<b>Scan</b>	The drive is enabled in Regen mode and is trying to synchronize to the supply	Enabled
<b>Supply Loss</b>	Supply loss condition has been detected	Enabled
<b>Deceleration</b>	The motor is being decelerated to zero speed / frequency because the final drive run has been deactivated	Enabled
<b>dc injection</b>	The drive is applying dc injection braking	Enabled
<b>Position</b>	Positioning / position control is active during an orientation stop	Enabled
<b>Trip</b>	The drive has tripped and no longer controlling the motor. The trip code appears in the lower display	Disabled
<b>Active</b>	The Regen unit is enabled and synchronized to the supply	Enabled
<b>Under Voltage</b>	The drive is in the under voltage state either in low voltage or high voltage mode	Disabled
<b>Heat</b>	The motor pre-heat function is active	Enabled
<b>Phasing</b>	The drive is performing a 'phasing test on enable'	Enabled

### 5.5.3 Alarm indications

An alarm is an indication given on the display by alternating the alarm string with the drive status string on the upper row and showing the alarm symbol in the last character in the upper row. Alarms strings are not displayed when a parameter is being edited, but the user will still see the alarm character on the upper row.

**Table 5-6 Alarm indications**

Alarm string	Description
<b>Brake Resistor</b>	Brake resistor overload. <i>Braking Resistor Thermal Accumulator</i> (10.039) in the drive has reached 75.0 % of the value at which the drive will trip.
<b>Motor Overload</b>	<i>Motor Protection Accumulator</i> (04.019) in the drive has reached 75.0 % of the value at which the drive will trip and the load on the drive is >100 %.
<b>Ind Overload</b>	Regen inductor overload. <i>Inductor Protection Accumulator</i> (04.019) in the drive has reached 75.0 % of the value at which the drive will trip and the load on the drive is >100 %.
<b>Drive Overload</b>	Drive over temperature. <i>Percentage Of Drive Thermal Trip Level</i> (07.036) in the drive is greater than 90 %.
<b>Auto Tune</b>	The autotune procedure has been initialized and an autotune in progress.
<b>Limit Switch</b>	Limit switch active. Indicates that a limit switch is active and that is causing the motor to be stopped.

**Table 5-7 Option module and NV media card and other status indications at power-up**

First row string	Second row string	Status
<b>Booting</b>	<b>Parameters</b>	Parameters are being loaded
Drive parameters are being loaded from a NV Media Card		
<b>Booting</b>	<b>User Program</b>	User program being loaded
User program is being loaded from a NV Media Card to the drive		
<b>Booting</b>	<b>Option Program</b>	User program being loaded
User program is being loaded from a NV Media Card to the option module in slot X		
<b>Writing To</b>	<b>NV Card</b>	Data being written to NV Media Card
Data is being written to a NV Media Card to ensure that its copy of the drive parameters is correct because the drive is in Auto or Boot mode		
<b>Waiting For</b>	<b>Power System</b>	Waiting for power stage
The drive is waiting for the processor in the power stage to respond after power-up		
<b>Waiting For</b>	<b>Options</b>	Waiting for an option module
The drive is waiting for the options modules to respond after power-up		
<b>Uploading From</b>	<b>Options</b>	Loading parameter database
At power-up it may be necessary to update the parameter database held by the drive because an option module has changed or because an applications module has requested changes to the parameter structure. This may involve data transfer between the drive an option modules. During this period 'Uploading From Options' is displayed		

## 5.6 Changing the operating mode

Changing the operating mode returns all parameters to their default value, including the motor parameters. *User security status* (00.049) and *User security code* (00.034) are not affected by this procedure).

### Procedure

Use the following procedure only if a different operating mode is required:

1. Ensure the drive is not enabled, i.e. terminal 31 is open or Pr **06.015** is Off (0)
2. Enter either of the following values in Pr **mm.000**, as appropriate:  
1253 (50Hz AC supply frequency)  
1254 (60Hz AC supply frequency)
3. Change the setting of Pr **00.048** as follows:

Pr 00.048 setting		Operating mode
	1	Open-loop
	2	RFC-A
	3	RFC-S
	4	Regen

The figures in the second column apply when serial communications are used.

4. Either:
  - Press the red reset button
  - Toggle the reset digital input
  - Carry out a drive reset through serial communications by setting Pr **10.038** to 100.

### NOTE

Entering 1253 or 1254 in Pr **mm.000** will only load defaults if the setting of Pr **00.048** has been changed.

## 5.7 Saving parameters

When changing a parameter in Menu 0, the new value is saved when pressing the Enter button to return to parameter view mode from parameter edit mode.

If parameters have been changed in the advanced menus, then the change will not be saved automatically. A save function must be carried out.

### Procedure

1. Select 'Save Parameters\*' in Pr **mm.000** (alternatively enter a value of 1001 in Pr **mm.000**)
2. Either:
  - Press the red reset button
  - Toggle the reset digital input, or
  - Carry out a drive reset through serial communications by setting Pr **10.038** to 100

## 5.8 Restoring parameter defaults

Restoring parameter defaults by this method saves the default values in the drives memory. *User security status* (00.049) and *User security code* (00.034) are not affected by this procedure).

### Procedure

1. Ensure the drive is not enabled, i.e. terminal 31 is open or Pr **06.015** is Off (0)
2. Select 'Reset 50 Hz Defs' or 'Reset 60 Hz Defs' in Pr **mm.000**. (alternatively, enter 1233 (50 Hz settings) or 1244 (60 Hz settings) in Pr **mm.000**).
3. Either:
  - Press the red  reset button
  - Toggle the reset digital input
  - Carry out a drive reset through serial communications by setting Pr **10.038** to 100

## 5.9 Parameter access level and security

The parameter access level determines whether the user has access to Menu 0 only or to all the advanced menus (Menus 1 to 41) in addition to Menu 0.

The User Security determines whether the access to the user is read only or read write.

Both the User Security and Parameter Access Level can operate independently of each other as shown in Table 5-8.

**Table 5-8 Parameter access level and security**

User security status (00.049)	Access level	User security (00.034)	Menu 0 status	Advanced menu status
0	Menu 0	None	RW	Not visible
1	All Menus	None	RW	RW
2	Read-only Menu 0	Open	RW	Not visible
		Closed	RO	Not visible
3	Read-only	Open	RW	RW
		Closed	RO	RO
4	Status only	Open	RW	RW
		Closed	Not visible	Not visible
5	No access	Open	RW	RW
		Closed	Not visible	Not visible

The default settings of the drive are Parameter Access Level Menu 0 and user Security Open i.e. read / write access to Menu 0 with the advanced menus not visible.

### 5.9.1 User Security Level / Access Level

The drive provides a number of different levels of security that can be set by the user via *User Security Status* (00.049); these are shown in the table below.

User Security Status (Pr 00.049)	Description
Menu 0 (0)	All writable parameters are available to be edited but only parameters in Menu 0 are visible
All menus (1)	All parameters are visible and all writable parameters are available to be edited
Read-only Menu 0 (2)	Access is limited to Menu 0 parameters only. All parameters are read-only
Read-only (3)	All parameters are read-only however all menus and parameters are visible
Status only (4)	The keypad remains in status mode and no parameters can be viewed or edited
No access (5)	The keypad remains in status mode and no parameters can be viewed or edited. Drive parameters cannot be accessed via a comms/ fieldbus interface in the drive or any option module

### 5.9.2 Changing the User Security Level /Access Level

The security level is determined by the setting of Pr **00.049** or Pr **11.044**. The Security Level can be changed through the keypad even if the User Security Code has been set.

### 5.9.3 User Security Code

The User Security Code, when set, prevents write access to any of the parameters in any menu.



#### Setting User Security Code

Enter a value between 1 and 2147483647 in Pr **00.034** and press the

 button; the security code has now been set to this value. In order to activate the security, the Security level must be set to desired level in Pr **00.049**. When the drive is reset, the security code will have been

activated and the drive returns to Menu 0 and the  symbol is displayed in the right hand corner of the keypad display. The value of Pr **00.034** will return to 0 in order to hide the security code.

#### Unlocking User Security Code

Select a parameter that need to be edited and press the  button, the upper display will now show 'Security Code'. Use the arrow buttons to set the security code and press the  button. With the correct security code entered, the display will revert to the parameter selected in edit mode.

If an incorrect security code is entered, the following message 'Incorrect security code' is displayed, then the display will revert to parameter view mode.

#### Disabling User Security

Unlock the previously set security code as detailed above. Set Pr **00.034** to 0 and press the  button. The User Security has now been disabled, and will not have to be unlocked each time the drive is powered up to allow read / write access to the parameters.

## 5.10 Displaying parameters with non-default values only

By selecting 'Show non-default' in Pr **mm.000** (Alternatively, enter 12000 in Pr **mm.000**), the only parameters that will be visible to the user will be those containing a non-default value. This function does not require a drive reset to become active. In order to deactivate this function, return to Pr **mm.000** and select 'No action' (alternatively enter a value of 0). Please note that this function can be affected by the access level enabled, refer to section 5.9 *Parameter access level and security* on page 36 for further information regarding access level.

## 5.11 Displaying destination parameters only

By selecting 'Destinations' in Pr **mm.000** (Alternatively enter 12001 in Pr **mm.000**), the only parameters that will be visible to the user will be destination parameters. This function does not require a drive reset to become active. In order to deactivate this function, return to Pr **mm.000** and select 'No action' (alternatively enter a value of 0).

Please note that this function can be affected by the access level enabled, refer to section 5.9 *Parameter access level and security* on page 36 for further information regarding access level.

## 5.12 Communications

The Unidrive M600 drive offers a 2 wire EIA 485 interface. This enables the drive set-up, operation and monitoring to be carried out with a PC or controller if required.

### 5.12.1 EIA 485 Serial communications

The EIA 485 interface provides two parallel RJ45 connectors allowing easy daisy chaining. The drive only supports Modbus RTU protocol.

The serial communications port of the drive is a RJ45 socket, which is isolated from the power stage and the other control terminals (see section 4.2 *Communication connections* on page 22 for connection and isolation details).

The communications port applies a 2 unit load to the communications network.

#### USB/EIA 232 to EIA 485 Communications

An external USB/EIA 232 hardware interface such as a PC cannot be used directly with the 2-wire EIA 485 interface of the drive. Therefore a suitable converter is required.

Suitable USB to EIA 485 and EIA 232 to EIA 485 isolated converters are available from Control Techniques as follows:

- CT USB Comms cable (CT Part No. 4500-0096)
- CT EIA 232 Comms cable (CT Part No. 4500-0087)

#### NOTE

When using the CT EIA 232 Comms cable the available baud rate is limited to 19.2 k baud.

When using one of the above converters or any other suitable converter with the drive, it is recommended that no terminating resistors be connected on the network. It may be necessary to 'link out' the terminating resistor within the converter depending on which type is used. The information on how to link out the terminating resistor will normally be contained in the user information supplied with the converter.

## Serial communications set-up parameters

The following parameters need to be set according to the system requirements.

Serial communications set-up parameters		
<i>Serial Mode</i> (00.035)	8 2 NP (0), 8 1 NP (1), 8 1 EP (2), 8 1 OP (3), 8 2 NP M (4), 8 1 NP M (5), 8 1 EP M (6), 8 1 OP M (7), 7 2 NP (8), 7 1 NP (9), 7 1 EP (10), 7 1 OP (11), 7 2 NP M (12), 7 1 NP M (13), 7 1 EP M (14), 7 1 OP M (15)	The drive only supports the Modbus RTU protocol and is always a slave. This parameter defines the supported data formats used by the EIA 485 comms port (if installed) on the drive. This parameter can be changed via the drive keypad, via a option module or via the comms interface itself.
<i>Serial Baud Rate</i> (00.036)	300 (0), 600 (1), 1200 (2), 2400 (3), 4800 (4), 9600 (5), 19200 (6), 38400 (7), 57600(8), 76800(9), 115200 (10)	This parameter can be changed via the drive keypad, via a option module or via the comms interface itself. If it is changed via the comms interface, the response to the command uses the original baud rate. The master should wait at least 20 ms before sending a new message using the new baud rate.
<i>Serial Address</i> (00.037)	1 to 247	This parameter defines the serial address and an addresses between 1 and 247 are permitted.
<i>Reset Serial Communications</i> (00.052)	0 to 1	When the above parameters are modified the changes do not have an immediate effect on the serial communication system. The new values are used after the next power up or if Reset Serial Communications is set to 1.

#### NOTE

Please refer to section 7.7 *CT Modbus RTU specification* on page 92 for further details on the CT Modbus RTU specification.

## 6 Basic parameters

Menu 0 is used to bring together various commonly used parameters for basic easy set up of the drive. All the parameters in Menu 0 appear in other menus in the drive (denoted by {...}). Menu 22 can be used to configure the parameters in Menu 0.

### Parameter ranges and Variable minimum/maximums:

Some parameters in the drive have a variable range with a variable minimum and a variable maximum value which is dependent on one of the following:

- The settings of other parameters
- The drive rating
- The drive mode
- Combination of any of the above

For more information please see section 10.1 *Parameter ranges and Variable minimum/maximums*: on page 109.

## 6.1 Menu 0: Basic parameters

Parameter			Range			Default			Type						
			OL	RFC-A	RFC-S	OL	RFC-A	RFC-S							
00.001	Minimum Reference Clamp	{01.007}	VM_NEGATIVE_REF_CLAMP1 Hz / rpm			0 Hz / rpm			RW	Num					US
00.002	Maximum Reference Clamp1	{01.006}	VM_POSITIVE_REF_CLAMP1 Hz / rpm			50 Hz default: 50.0 Hz 60 Hz default: 60.0 Hz	50 Hz default: 1500.0 rpm 60 Hz default: 1800.0 rpm		RW	Num					US
00.003	Acceleration Rate 1	{02.011}	0.0 to VM_ACCEL_RATE s/100 Hz	0.000 to VM_ACCEL_RATE s/1000 rpm		5.0 s/100 Hz		2.000 s/1000 rpm		RW	Num				US
00.004	Deceleration Rate 1	{02.021}	0.0 to VM_ACCEL_RATE s/100 Hz	0.000 to VM_ACCEL_RATE s/1000 rpm		10.0 s/100 Hz		2.000 s/1000 rpm		RW	Num				US
00.005	Reference Selector	{01.014}	A1 A2 (0), A1 Preset (1), A2 Preset (2) Preset (3), Keypad (4), Precision (5) Keypad Ref (6)			A1 A2 (0)			RW	Txt					US
00.006	Symmetrical Current Limit	{04.007}	0.0 to VM_MOTOR1_CURRENT_LIMIT %			165.0 %*		175.0 %**		RW	Num		RA		US
00.007	Open-loop Control Mode / Action On Enable	{05.014}	Ur S (0), Ur I (1), Fixed (2), Ur Auto (3), Ur I (4), Square (5)			Ur I (4)				RW	Txt				US
	Speed Controller Proportional Gain Kp1	{03.010}	0.0000 to 200.000 s/rad					0.0100 s/rad		RW	Num				US
00.008	Low Frequency Voltage Boost	{05.015}	0.0 to 25.0 %			3.0 %				RW	Num				US
	Speed Controller Integral Gain Ki1	{03.011}	0.00 to 655.35 s <sup>2</sup> /rad					0.05 s <sup>2</sup> /rad		RW	Num				US
00.009	Dynamic V to F Select	{05.013}	Off (0) or On (1)			Off (0)				RW	Bit				US
	Speed Controller Differential Feedback Gain Kd 1	{03.012}	0.00000 to 0.65535 1/rad					0.00000 1/rad		RW	Num				US
00.010	Motor Rpm	{05.004}	±180000 rpm							RO	Num	ND	NC	PT	FI
	Speed Feedback	{03.002}	VM_SPEED rpm							RO	Num	ND	NC	PT	FI
00.011	Output Frequency	{05.001}	VM_SPEED_FREQ_REF Hz	±2000.0 Hz						RO	Num	ND	NC	PT	FI
00.012	Current Magnitude	{04.001}	0.000 to VM_DRIVE_CURRENT_UNIPOLAR A							RO	Bit	ND	NC	PT	FI
00.013	Torque Producing Current	{04.002}	VM_DRIVE_CURRENT A							RO	Bit	ND	NC	PT	FI
00.014	Torque Mode Selector	{04.011}	0 or 1		0 to 5		0			RW	Num				US
00.015	Ramp Mode	{02.004}	Fast (0), Standard (1), Std boost (2)	Fast (0), Standard (1)		Standard (1)			RW	Txt					US
00.016	Ramp Enable	{02.002}	Off (0) or On (1)					On (1)		RW	Bit				US
00.017	Digital Input 6 Destination	{08.026}	0.000 to 59.999				06.031		RW	Num	DE		PT		US
	Current Reference Filter 1 Time Constant	{04.012}			0.0 to 25.0 ms				RW	Num					US
00.019	Analog Input 2 Mode	{07.011}	4-20 mA Low (-4), 20-4 mA Low (-3), 4-20 mA Hold (-2), 20-4 mA Hold (-1), 0-20 mA (0), 20-0 mA (1), 4-20 mA Trip (2), 20-4 mA Trip (3), 4-20 mA (4), 20-4 mA (5), Volt (6)			Volt (6)			RW	Txt					US
00.020	Analog Input 2 Destination	{07.014}	00.000 to 59.999					01.037		RW	Num	DE		PT	US
00.021	Analog Input 3 Mode	{07.015}	Volt (6), Therm Short Cct (7), Thermistor (8), Therm No Trip (9)			Volt (6)			RW	Txt					US
00.022	Bipolar Reference Enable	{01.010}	Off (0) or On (1)			Off (0)			RW	Bit					US
00.023	Jog Reference	{01.005}	0.0 to 400.0 Hz	0.0 to 4000.0 rpm				0.0 Hz / rpm		RW	Num				US
00.024	Preset Reference 1	{01.021}	VM_SPEED_FREQ_REF Hz / rpm					0.0 Hz / rpm		RW	Num				US
00.025	Preset Reference 2	{01.022}	VM_SPEED_FREQ_REF Hz / rpm					0.0 Hz / rpm		RW	Num				US
00.026	Preset Reference 3	{01.023}	VM_SPEED_FREQ_REF Hz			0.0 Hz				RW	Num				US
	Overspeed Threshold	{03.008}	0 to 40000 rpm					0 rpm		RW	Num				US
00.027	Preset Reference 4	{01.024}	VM_SPEED_FREQ_REF Hz			0.0 Hz				RW	Num				US
00.028	Enable Auxiliary Key	{06.013}	Disabled (0), Forward / Reverse (1), Reverse (2)			Disabled (0)			RW	Txt					US
00.029	NV Media Card File Previously Loaded	{11.036}	0 to 999					0		RO	Num		NC	PT	
00.030	Parameter Cloning	{11.042}	None (0), Read (1), Program (2), Auto (3), Boot (4)			None (0)			RW	Txt			NC		US
00.031	Rated Voltage	{11.033}	200 V (0), 400 V (1), 575 V (2), 690 V (3)							RO	Txt	ND	NC	PT	
00.032	Maximum Heavy Duty Rating	{11.032}	0.000 to 99999.999 A							RO	Num	ND	NC	PT	

Parameter			Range			Default			Type					
			OL	RFC-A	RFC-S	OL	RFC-A	RFC-S						
00.033	Catch A Spinning Motor	{06.009}	Disable (0), Enable (1), Fwd Only (2), Rev Only (3)			Disable (0)			RW	Txt				US
	Rated Speed Optimization Select	{05.016}		Disabled (0), Classic slow (1), Classic fast (2), Combined (3), VARs only (4), Voltage only (5)			Disabled (0)			RW	Txt			
00.034	User Security Code	{11.030}	0 to 2147483647			0			RW	Num	ND	NC	PT	US
00.035	Serial Mode	{11.024}	8 2 NP (0), 8 1 NP (1), 8 1 EP (2), 8 1 OP (3), 8 2 NP M (4), 8 1 NP M (5), 8 1 EP M (6), 8 1 OP M (7), 7 2 NP (8), 7 1 NP (9), 7 1 EP (10), 7 1 OP (11), 7 2 NP M (12), 7 1 NP M (13), 7 1 EP M (14), 7 1 OP M (15)			8 2 NP (0)			RW	Txt				US
00.036	Serial Baud Rate	{11.025}	300 (0), 600 (1), 1200 (2), 2400 (3), 4800 (4), 9600 (5), 19200 (6), 38400 (7), 57600 (8), 76800 (9), 115200 (10)			19200 (6)			RW	Txt				US
00.037	Serial Address	{11.023}	1 to 247			1			RW	Num				US
00.038	Current Controller Kp Gain	{04.013}	0 to 30000			20	150		RW	Num				US
00.039	Current Controller Ki Gain	{04.014}	0 to 30000			40	2000		RW	Num				US
00.040	Auto-tune	{05.012}	0 to 2	0 to 5	0 to 6	0			RW	Num		NC		
00.041	Maximum Switching Frequency	{05.018}	2 (0) kHz, 3 (1) kHz, 4 (2) kHz, 6 (3) kHz, 8 (4) kHz, 12 (5) kHz, 16 (6) kHz			3 (1) kHz			RW	Txt		RA		US
00.042	Number Of Motor Poles	{05.011}	Automatic (0) to 480 Poles (240)			Automatic (0)		8 Poles (4)	RW	Num				US
00.043	Rated Power Factor***	{05.010}	0.000 to 1.000			0.850			RW	Num		RA		US
00.044	Rated Voltage	{05.009}	0 to VM_AC_VOLTAGE_SET V			200V drive: 230V 50Hz default 400V drive: 400V 60Hz default 400V drive: 460V 575V drive: 575V 690V drive: 690V			RW	Num		RA		US
00.045	Rated Speed	{05.008}	0 to 33000 rpm	0.00 to 33000.00 rpm	0.00 to 33000.00 rpm	Eur - 1500 rpm USA - 1800 rpm	Eur - 1450.00 rpm USA - 1750.00 rpm	3000.00 rpm	RW	Num				US
00.046	Rated Current	{05.007}	0.000 to VM_RATED_CURRENT A			Maximum Heavy Duty Rating (Pr 00.032 {11.032}) A			RW	Num		RA		US
00.047	Rated Frequency	{05.006}	0.0 to 550.0 Hz			50Hz: 50.0 60Hz: 60.0			RW	Num				US
	Volts per 1000 rpm	{05.033}				0 to 10000 V / 1000 rpm			98 V / 1000 rpm	RW	Num			US
00.048	User Drive Mode	{11.031}	Open-loop (1), RFC-A (2), RFC-S (3), Regen (4)			Open-loop (1)	RFC-A (2)	RFC-S (3)	RW	Txt	ND	NC	PT	
00.049	User Security Status	{11.044}	Menu 0 (0), All Menus (1), Read-only Menu 0 (2), Read-only (3), Status Only (4), No Access (5)			Menu 0 (0)			RW	Txt	ND		PT	
00.050	Software Version	{11.029}	0 to 99999999						RO	Num	ND	NC	PT	
00.051	Action On Trip Detection	{10.037}	00000 to 11111			00000			RW	Bin				US
00.052	Reset Serial Communications	{11.020}	Off (0) or On (1)			Off (0)			RW	Bit	ND	NC		
00.053	Motor Thermal Time Constant 1	{04.015}	1.0 to 3000.0 s			89.0 s			RW	Num				US
00.054	RFC Low Speed Mode	{05.064}				Injection (0), Non-salient (1) Current (2), Current No Test (3)			Non-salient (1)	RW	Txt			US
00.055	Low Speed Sensorless Mode Current	{05.071}				0.0 to 1000.0 %			20.0 %	RW	Num		RA	US
00.056	No-load Lq	{05.072}				0.000 to 500.000 mH			0.000 mH	RW	Num		RA	US
00.057	Iq Test Current For Inductance Measurement	{05.075}				0 to 200 %			100 %	RW	Num			US
00.058	Phase Offset At Iq Test Current	{05.077}				±90.0 °			0.0 °	RW	Num		RA	US
00.059	Lq At The Defined Iq Test Current	{05.078}				0.000 to 500.000 mH			0.000 mH	RW	Num		RA	US
00.060	Id Test Current for Inductance Measurement	{05.082}				-100 to 0 %			-50 %	RW	Num			US
00.061	Lq At The Defined Id Test Current	{05.084}				0.000 to 500.000 mH			0.000 mH	RW	Num		RA	US

\* For size 9 and above the default is 141.9 %

\*\* For size 9 and above the default is 150.0 %

\*\*\* Following a rotating autotune Pr 00.043 {05.010} is continuously written by the drive, calculated from the value of Stator Inductance (Pr 05.025). To manually enter a value into Pr 00.043 {05.010},

Pr 05.025 will need to be set to 0. Please refer to the description of Pr 05.010 in the *Parameter Reference Guide* for further details

RW	Read / Write	RO	Read only	Num	Number parameter	Bit	Bit parameter	Txt	Text string	Bin	Binary parameter	FI	Filtered
ND	No default value	NC	Not copied	PT	Protected parameter	RA	Rating dependent	US	User save	PS	Power-down save	DE	Destination



Figure 6-1 Menu 0 logic diagram

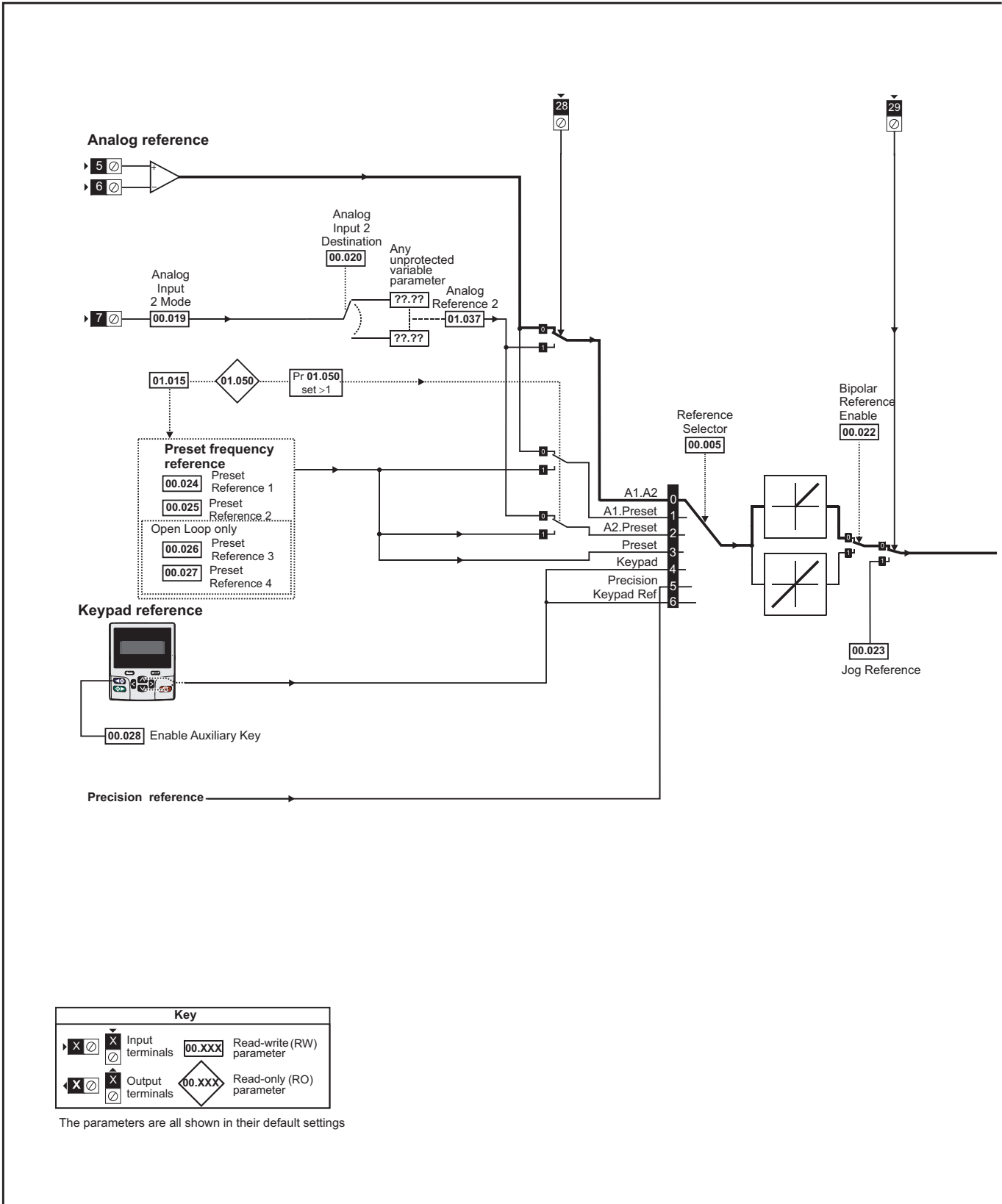

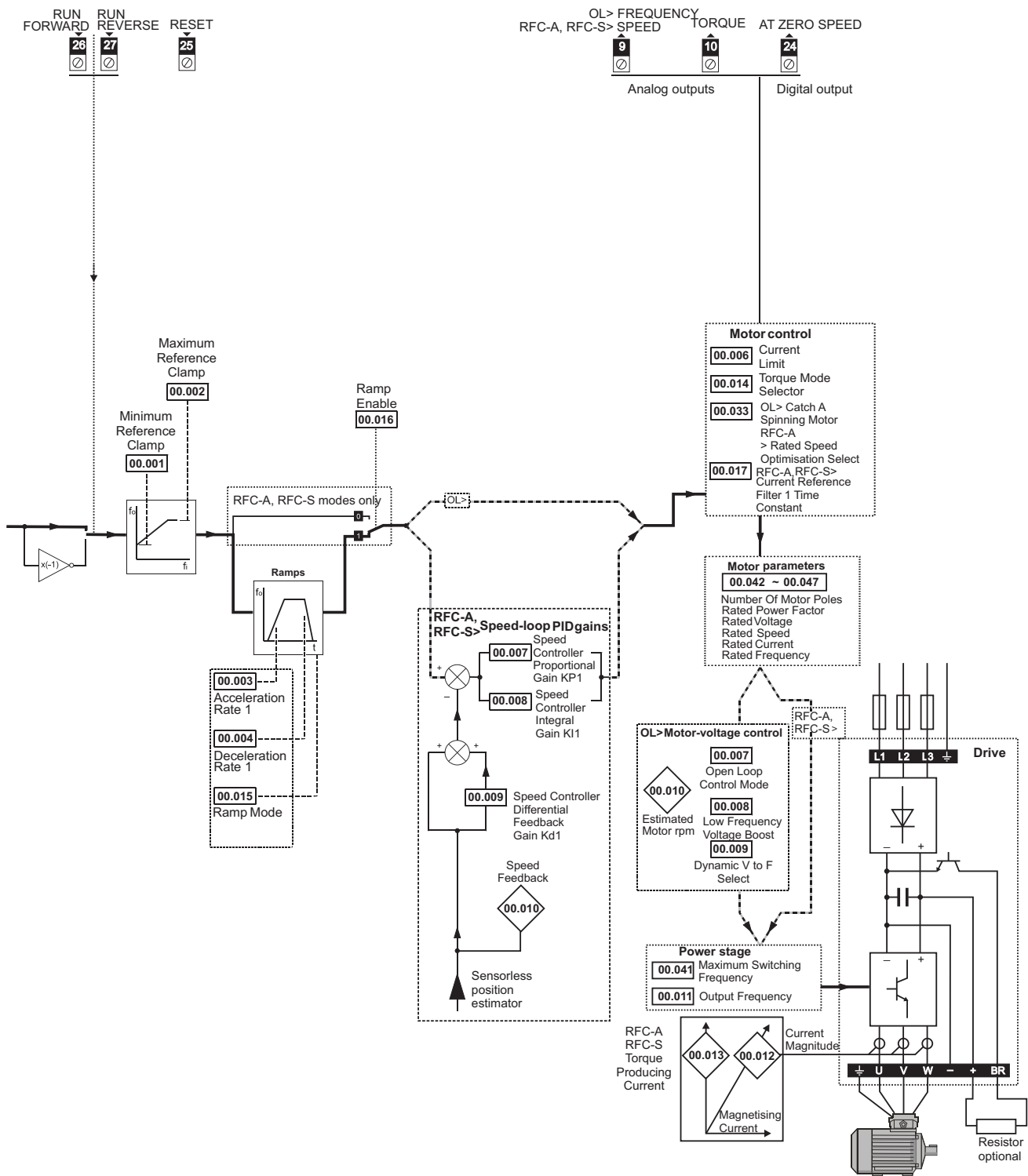

## 6.2 Parameter descriptions

### 6.2.1 Pr mm.000

Pr **mm.000** is available in all menus, commonly used functions are provided as text strings in Pr **mm.000** shown in Table 6-1. The functions in Table 6-1 can also be selected by entering the appropriate numeric values (as shown in Table 6-2) in Pr **mm.000**. For example, enter 4001 in Pr **mm.000** to store drive parameters on an NV media card.

**Table 6-1 Commonly used functions in xx.000**

Value	Equivalent value	String	Action
0	0	[No Action]	
1001	1	[Save parameters]	Save parameter under all conditions
6001	2	[Load file 1]	Load the drive parameters or user program file from NV media card file 001
4001	3	[Save to file 1]	Transfer the drive parameters to parameter file 001
6002	4	[Load file 2]	Load the drive parameters or user program file from NV media card file 002
4002	5	[Save to file 2]	Transfer the drive parameters to parameter file 002
6003	6	[Load file 3]	Load the drive parameters or user program file from NV media card file 003
4003	7	[Save to file 3]	Transfer the drive parameters to parameter file 003
12000	8	[Show non-default]	Displays parameters that are different from defaults
12001	9	[Destinations]	Displays parameters that are set
1233	10	[Reset 50Hz Defs]	Load parameters with standard (50 Hz) defaults
1244	11	[Reset 60Hz Defs]	Load parameters with US (60 Hz) defaults
1070	12	[Reset modules]	Reset all option modules
11001	13	[Read Enc. NP P1]	No function
11051	14	[Read Enc. NP P2]	

**Table 6-2 Functions in Pr mm.000**

Value	Action
1000	Save parameters when <i>Under Voltage Active</i> (Pr <b>10.016</b> ) is not active and <i>Low Under Voltage Threshold Select</i> mode (Pr <b>06.067</b> = Off) is not active.
1001	Save parameter under all conditions
1070	Reset all option modules
1233	Load standard (50 Hz) defaults
1234	Load standard (50 Hz) defaults to all menus except option module menus (i.e 15 to 20 and 24 to 28)
1244	Load US (60 Hz) defaults
1245	Load US (60 Hz) defaults to all menus except option module menus (i.e 15 to 20 and 24 to 28)
1253	Change drive mode and load standard (50 Hz) defaults
1254	Change drive mode and load US (60 Hz) defaults
1255	Change drive mode and load standard (50 Hz) defaults except for menus 15 to 20 and 24 to 28
1256	Change drive mode and load US (60 Hz) defaults except for menus 15 to 20 and 24 to 28
1299	Reset {Stored HF} trip.
2001*	Create a boot file on a non-volatile media card based on the present drive parameters including all Menu 20 parameters
4yyy*	NV media card: Transfer the drive parameters to parameter file xxx
5yyy*	NV media card: Transfer the onboard user program to onboard user program file xxx
6yyy*	NV media card: Load the drive parameters from parameter file xxx or the onboard user program from onboard user program file xxx
7yyy*	NV media card: Erase file xxx
8yyy*	NV Media card: Compare the data in the drive with file xxx
9555*	NV media card: Clear the warning suppression flag
9666*	NV media card: Set the warning suppression flag
9777*	NV media card: Clear the read-only flag
9888*	NV media card: Set the read-only flag
9999*	NV media card: Erase and format the NV media card
59999	Delete onboard user program
12000**	Only display parameters that are different from their default value. This action does not require a drive reset.
12001**	Only display parameters that are used to set-up destinations (i.e. DE format bit is 1). This action does not require a drive reset.
40yyy	Back-up all drive data.
60yyy	Load all drive data.

\* See Chapter 8 *NV Media Card Operation* on page 99 for more information on these functions.

\*\* These functions do not require a drive reset to become active. All other functions require a drive reset to initiate the function.

To allow easy access to some commonly used functions, refer to the table overleaf. Equivalent values and strings are also provided in the table above.

## 6.3 Full descriptions

**Table 6-3 Key to parameter table coding**

Coding	Attribute
<b>RW</b>	Read/Write: can be written by the user
<b>RO</b>	Read only: can only be read by the user
<b>Bit</b>	1 bit parameter. 'On' or 'Off' on the display
<b>Num</b>	Number: can be uni-polar or bi-polar
<b>Txt</b>	Text: the parameter uses text strings instead of numbers.
<b>Bin</b>	Binary parameter
<b>IP</b>	IP Address parameter
<b>Mac</b>	Mac Address parameter
<b>Date</b>	Date parameter
<b>Time</b>	Time parameter
<b>Chr</b>	Character parameter
<b>FI</b>	Filtered: some parameters which can have rapidly changing values are filtered when displayed on the drive keypad for easy viewing.
<b>DE</b>	Destination: This parameter selects the destination of an input or logic function.
<b>RA</b>	Rating dependent: this parameter is likely to have different values and ranges with drives of different voltage and current ratings. Parameters with this attribute will be transferred to the destination drive by non-volatile storage media when the rating of the destination drive is different from the source drive and the file is a parameter file. However, the values will be transferred if only the current rating is different and the file is a difference from default type file.
<b>ND</b>	No default: The parameter is not modified when defaults are loaded
<b>NC</b>	Not copied: not transferred to or from non-volatile media during copying.
<b>PT</b>	Protected: cannot be used as a destination.
<b>US</b>	User save: parameter saved in drive EEPROM when the user initiates a parameter save.
<b>PS</b>	Power-down save: parameter automatically saved in drive EEPROM when the under volts (UV) state occurs.

### 6.3.1 Parameter x.00

00.000 {mm.000} Parameter zero				
RW	Num	ND	NC	PT
↕	0 to 65,535	⇒		

### 6.3.2 Speed limits

00.001 {01.007} Minimum Reference Clamp		
RW	Num	US
OL	VM_NEGATIVE_REF_CLAMP1 Hz / rpm	0.0 Hz
RFC-A	↕	⇒
RFC-S		0.0 rpm

(When the drive is jogging, [00.001] has no effect.)

#### Open-loop

Set Pr **00.001** at the required minimum output frequency of the drive for both directions of rotation. The drive speed reference is scaled between Pr **00.001** and Pr **00.002**. [00.001] is a nominal value; slip compensation may cause the actual frequency to be higher.

#### RFC-A / RFC-S

Set Pr **00.001** at the required minimum motor speed for both directions of rotation. The drive speed reference is scaled between Pr **00.001** and Pr **00.002**.

00.002 {01.006} Maximum Reference Clamp		
RW	Num	US
OL	VM_POSITIVE_REF_CLAMP1 Hz / rpm	50Hz default: 50.0 Hz 60Hz default: 60.0 Hz
RFC-A	↕	⇒
RFC-S		50Hz default: 1500.0 rpm 60Hz default: 1800.0 rpm

(The drive has additional over-speed protection).

#### Open-loop

Set Pr **00.002** at the required maximum output frequency for both directions of rotation. The drive speed reference is scaled between Pr **00.001** and Pr **00.002**. [00.002] is a nominal value; slip compensation may cause the actual frequency to be higher.

#### RFC-A / RFC-S

Set Pr **00.002** at the required maximum motor speed for both directions of rotation. The drive speed reference is scaled between Pr **00.001** and Pr **00.002**.

For operating at high speeds see section 7.6 *High speed operation* on page 90.

### 6.3.3 Ramps, speed reference selection, current limit

00.003 {02.011} Acceleration Rate 1		
RW	Num	US
OL	0.0 to VM_ACCEL_RATE	5.0 s/100 Hz
RFC-A	↕	⇒
RFC-S	0.000 to VM_ACCEL_RATE	2.000 s/1000 rpm

Set Pr **00.003** at the required rate of acceleration.

Note that larger values produce lower acceleration. The rate applies in both directions of rotation.

00.004 {02.021} Deceleration Rate 1		
RW	Num	US
OL	0.0 to VM_ACCEL_RATE	10.0 s/100 Hz
RFC-A	↕	⇒
RFC-S	0.000 to VM_ACCEL_RATE	2.000 s/1000 rpm

Set Pr **00.004** at the required rate of deceleration.

Note that larger values produce lower deceleration. The rate applies in both directions of rotation.

00.005 {01.014} Reference Selector												
RW	Txt											US
OL	A1 A2 (0), A1 Preset (1), A2 Preset (2), Preset (3), Keypad (4), Precision (5), Keypad Ref (6)	⇕	⇒	A1 A2 (0)								
RFC-A												
RFC-S												

Use Pr **00.005** to select the required frequency/speed reference as follows:

Setting	Description
A1 A2	0 Analog input 1 OR analog input 2 selectable by digital input, terminal 28
A1 Preset	1 Analog input 1 OR preset frequency/speed
A2 Preset	2 Analog input 2 OR preset frequency/speed
Preset	3 Pre-set frequency/speed
Keypad	4 Keypad mode
Precision	5 Precision reference
Keypad Ref	6 Keypad Reference

00.006 {04.007} Symmetrical Current Limit												
RW	Num											US
OL	0.0 to VM_MOTOR1_CURRENT_LIMIT %	⇕	⇒	165 %								
RFC-A												
RFC-S				175 %								

Pr **00.006** limits the maximum output current of the drive (and hence maximum motor torque) to protect the drive and motor from overload. Set Pr **00.006** at the required maximum torque as a percentage of the rated torque of the motor, as follows:

$$[00.006] = \frac{T_R}{T_{RATED}} \times 100 (\%)$$

Where:

$T_R$  Required maximum torque  
 $T_{RATED}$  Motor rated torque

Alternatively, set Pr **00.006** at the required maximum active (torque-producing) current as a percentage of the rated active current of the motor, as follows:

$$[00.006] = \frac{I_R}{I_{RATED}} \times 100 (\%)$$

Where:

$I_R$  Required maximum active current  
 $I_{RATED}$  Motor rated active current

### 6.3.4 Voltage boost, (open-loop), Speed-loop PID gains (RFC-A / RFC-S)

00.007 {05.014} Open-loop Control Mode (OL)												
00.007 {03.010} Speed Controller Proportional Gain Kp1 (RFC)												
RW	Txt / Num											US
OL	Ur S (0), Ur (1), Fixed (2), Ur Auto (3), Ur I (4), Square (5)	⇕	⇒	Ur I (4)								
RFC-A												
RFC-S				0.0100 s/rad								

#### Open-loop

There are six voltage modes available, which fall into two categories, vector control and fixed boost. For further details, refer to section 7.1.1 *Open loop motor control* on page 77.

#### RFC-A/ RFC-S

Pr **00.007 (03.010)** operates in the feed-forward path of the speed-control loop in the drive. See Figure 10-4 *Menu 3 RFC-A, RFC-S logic diagram* on page 128 for a schematic of the speed controller. For information on setting up the speed controller gains, refer to Chapter 7 *Optimization* on page 77.

00.008 {05.015} Low Frequency Voltage Boost (OL)												
00.008 {03.011} Speed Controller Integral Gain Ki1 (RFC)												
RW	Num											US
OL	0.0 to 25.0 %	⇕	⇒	3.0 %								
RFC-A												
RFC-S				0.05 s <sup>2</sup> /rad								

#### Open-loop

When *Open-loop Control Mode* (00.007) is set at **Fd** or **SrE**, set Pr **00.008 (05.015)** at the required value for the motor to run reliably at low speeds.

Excessive values of Pr **00.008** can cause the motor to be overheated.

#### RFC-A/ RFC-S

Pr **00.008 (03.011)** operates in the feed-forward path of the speed-control loop in the drive. For information on setting up the speed controller gains See section 10.4 *Menu 3: Speed feedback and speed control* on page 127. For information on setting up the speed controller gains, refer to Chapter 7 *Optimization* on page 77.

00.009 {05.013} Dynamic V to F Select (OL)												
00.009 {03.012} Speed Controller Differential Feedback Gain Kd 1 (RFC)												
RW	Bit											US
OL	Off (0) or On (1)	⇕	⇒	Off (0)								
RFC-A												
RFC-S				0.00000 1/rad								

#### Open-loop

Set Pr **00.009 (05.013)** at 0 when the V/f characteristic applied to the motor is to be fixed. It is then based on the rated voltage and frequency of the motor.

Set Pr **00.009** at 1 when reduced power dissipation is required in the motor when it is lightly loaded. The V/f characteristic is then variable resulting in the motor voltage being proportionally reduced for lower motor currents. Figure 6-2 shows the change in V/f slope when the motor current is reduced.

**Figure 6-2 Fixed and variable V/f characteristics**

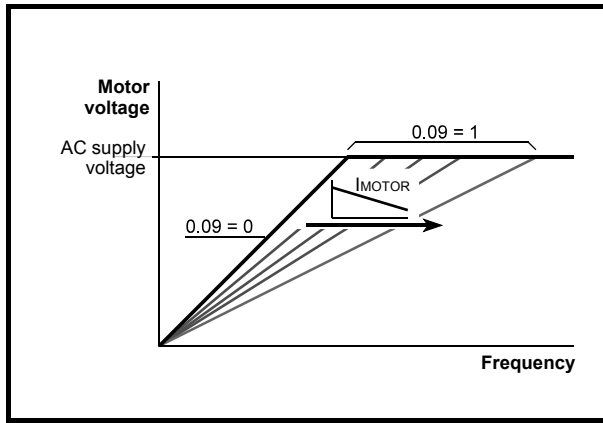

**RFC-A / RFC-S**

Pr **00.009 (03.012)** operates in the feedback path of the speed-control loop in the drive. See Figure 10-4 *Menu 3 RFC-A, RFC-S logic diagram* on page 128 for a schematic of the speed controller. For information on setting up the speed controller gains, refer to Chapter 7 *Optimization* on page 77.

**6.3.5 Monitoring**

00.010 {05.004} Motor Rpm												
RO	Bit										US	
OL	↕	±180000 rpm						⇒				

**Open-loop**

Pr **00.010 (05.004)** indicates the value of motor speed that is estimated from the following:

- 02.001 Post Ramp Reference
- 00.042 Number Of Motor Poles

00.010 {03.002} Speed Feedback												
RO	Num	FI				ND	NC	PT				
RFC-A	↕	VM_SPEED rpm						⇒				
RFC-S												

**RFC-A / RFC-S**

Pr **00.010 (03.002)** indicates the value of motor speed that is obtained from the speed feedback.

00.011 {05.001} Output Frequency (OL and RFC-A)												
RO	Num	FI				ND	NC	PT				
OL	↕	VM_SPEED_FREQ_REF Hz						⇒				
RFC-A												
RFC-S	↕	±2000.0 Hz						⇒				

**Open-loop / RFC-A / RFC-S**

Pr **00.011** displays the frequency at the drive output.

00.012 {04.001} Current Magnitude												
RO	Bit	FI				ND	NC	PT				
OL		0.000 to VM_DRIVE_CURRENT_UNIPOLAR A						⇒				
RFC-A	↕											
RFC-S												

Pr **00.012** displays the rms value of the output current of the drive in each of the three phases. The phase currents consist of an active component and a reactive component, which can form a resultant current vector as shown in the following diagram:

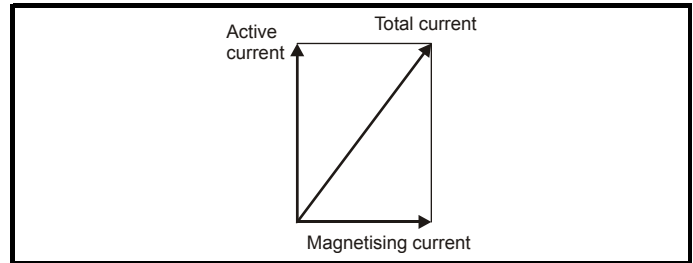

The active current is the torque producing current and the reactive current is the magnetizing or flux-producing current.

00.013 {04.002} Torque Producing Current												
RO	Bit	FI				ND	NC	PT				
OL								⇒				
RFC-A	↕	VM_DRIVE_CURRENT A						⇒				
RFC-S												

When the motor is being driven below its rated speed, the torque is proportional to [00.013].

**6.3.6 Jog reference, Ramp mode selector, Stop and torque mode selectors**

Pr **00.014** is used to select the required control mode of the drive as follows:

00.014 {04.011} Torque Mode Selector												
RW	Num										US	
OL	↕	0 or 1						⇒	0			
RFC-A	↕	0 to 5						⇒	0			
RFC-S												

Setting	Open-Loop	RFC-A/S
0	Frequency control	Speed control
1	Torque control	Torque control
2		Torque control with speed override
3		Coiler/uncoiler mode
4		Speed control with torque feed-forward
5		Bi-directional torque control with speed override

00.015 {02.004} Ramp Mode Select	
RW	Txt
OL	Fast (0), Standard (1), Std boost (2) ⇒ Standard (1)
RFC-A	Fast (0), Standard (1) ⇒ Standard (1)
RFC-S	

Pr 00.015 sets the ramp mode of the drive as shown below:

### 0: Fast ramp

Fast ramp is used where the deceleration follows the programmed deceleration rate subject to current limits. This mode must be used if a braking resistor is connected to the drive.

### 1: Standard ramp

Standard ramp is used. During deceleration, if the voltage rises to the standard ramp level (Pr 02.008) it causes a controller to operate, the output of which changes the demanded load current in the motor. As the controller regulates the link voltage, the motor deceleration increases as the speed approaches zero speed. When the motor deceleration rate reaches the programmed deceleration rate the controller ceases to operate and the drive continues to decelerate at the programmed rate. If the standard ramp voltage (Pr 02.008) is set lower than the nominal DC bus level the drive will not decelerate the motor, but it will coast to rest. The output of the ramp controller (when active) is a current demand that is fed to the frequency changing current controller (Open-loop modes) or the torque producing current controller (RFC-A or RFC-S modes). The gain of these controllers can be modified with Pr 00.038 {04.013} and Pr 00.039 {04.014}.

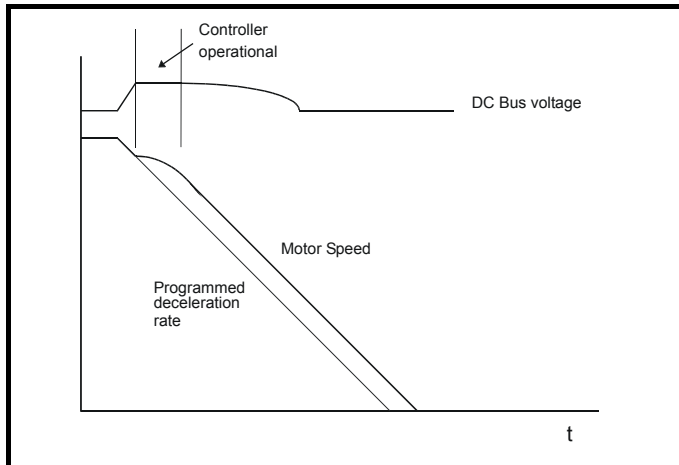

### 2: Standard ramp with motor voltage boost

This mode is the same as normal standard ramp mode except that the motor voltage is boosted by 20 %. This increases the losses in the motor, dissipating some of the mechanical energy as heat giving faster deceleration.

00.016 {02.002} Ramp Enable	
RW	Bit
OL	⇒
RFC-A	Off (0) or On (1) ⇒ On (1)
RFC-S	

Setting Pr 00.016 to 0 allows the user to disable the ramps. This is generally used when the drive is required to closely follow a speed reference which already contains acceleration and deceleration ramps.

00.017 {08.026} Digital Input 6 Destination				
RW	Num	DE	PT	US
OL	00.000 to 59.999	⇒	06.031	

### Open-loop

Pr 00.017 sets the destination of digital input T29.

00.017 {04.012} Current Reference Filter Time Constant		
RW	Num	US
RFC-A	0.0 to 25.0 ms ⇒	1.0 ms
RFC-S		2.0 ms

### RFC-A / RFC-S

A first order filter, with a time constant defined by Pr 00.017, is provided on the current demand to reduce acoustic noise and vibration produced as a result of position feedback quantisation noise. The filter introduces a lag in the speed loop, and so the speed loop gains may need to be reduced to maintain stability as the filter time constant is increased.

00.019 {07.011} Analog Input 2 Mode		
RW	Num	US
OL	4-20 mA Low (-4), 20-4 mA Low (-3), 4-20 mA Hold (-2), 20-4 mA Hold (-1), 0-20 mA (0), 20-0 mA (1), 4-20 mA Trip (2), 20-4 mA Trip (3), 4-20 mA (4), 20-4 mA (5), Volt (6)	⇒ Volt (6)
RFC-A		
RFC-S		

In modes 2 and 3, a current loop loss trip is generated if the current falls below 3 mA.

In modes -4, -3, 2 and 3 the analog input level goes to 0.0 % if the input current falls below 3 mA.

In modes -2 and -1 the analog input remains at the value it had in the previous sample before the current fell below 3 mA.

Pr Value	Pr string	Comments
-4	4-20 mA Low	4-20 mA low value on current loss (1)
-3	20-4 mA Low	20-4 mA low value on current loss (1)
-2	4-20 mA Hold	4-20 mA hold at level before loss on current loss
-1	20-4 mA Hold	20-4 mA hold at level before loss on current loss
0	0-20 mA	
1	20-0 mA	
2	4-20 mA Trip	4-20 mA trip on current loss
3	20-4 mA Trip	20-4 mA trip on current loss
4	4-20 mA	
5	20-4 mA	
6	Volt	

00.020 {07.014} Analog Input 2 Destination				
RW	Num	DE	PT	US
OL	00.000 to 59.999 ⇒	01.037		
RFC-A				
RFC-S				

Pr 00.020 sets the destination of analog input 2.

00.021 {07.015} Analog Input 3 Mode												
RW	Txt										US	
OL		Volt (6),						Volt (6)				
RFC-A	⇕	Therm Short Cct (7),					⇒					
RFC-S		Thermistor (8),										
		Therm No Trip (9)										

00.025 {01.022} Preset Reference 2												
RW	Num										US	
OL		VM_SPEED_FREQ_						0.0 Hz / rpm				
RFC-A	⇕	REF Hz / rpm					⇒					
RFC-S												

Pr value	Pr string	Comments
6	Volt	
7	Therm Short Cct	Temperature measurement input with short circuit detection
8	Thermistor	Temperature measurement without short circuit detection
9	Therm No Trip	Temperature measurement input with no trips

00.026 {01.023} Preset Reference 3 (OL)												
00.026 {03.008} Overspeed Threshold (RFC)												
RW	Num										US	
OL	⇕	VM_SPEED_FREQ_R						0.0 Hz / rpm				
RFC-A		EF Hz					⇒					
RFC-S	⇕	0 to 40000 rpm										

**Open-loop**



If the preset reference has been selected (see Pr 00.005), the speed at which the motor runs is determined by these parameters.

**RFC-A / RFC-S**

If the speed feedback Pr 00.010 {03.002} exceeds this level in either direction, an overspeed trip is produced. If this parameter is set to zero, the overspeed threshold is automatically set to 120 % x SPEED\_FREQ\_MAX.

00.022 {01.010} Bipolar Reference Enable												
RW	Bit										US	
OL		Off (0) or On (1)						Off (0)				
RFC-A	⇕						⇒					
RFC-S												

Pr 00.022 determines whether the reference is uni-polar or bi-polar as follows:

Pr 00.022	Function	
0	Unipolar speed/frequency reference	
1	Bipolar speed/frequency reference	

00.027 {01.024} Preset Reference 4 (OL)												
RW	Num										US	
OL	⇕	VM_SPEED_FREQ_R						0.0				
RFC-A		EF Hz					⇒					
RFC-S	⇕						⇒					

**Open-loop**

Refer to Pr 00.024 to Pr 00.026.

00.023 {01.005} Jog Reference												
RW	Num										US	
OL	⇕	0.0 to 400.0 Hz					⇒	0.0				
RFC-A	⇕	0.0 to 4000.0 rpm					⇒	0.0				
RFC-S												

Enter the required value of jog frequency/speed.

The frequency/speed limits affect the drive when jogging as follows:

Frequency-limit parameter	Limit applies
Pr 00.001 Minimum reference clamp	No
Pr 00.002 Maximum reference clamp	Yes

00.028 {06.013} Enable Auxiliary Key												
RW	Txt										US	
OL		Disabled (0), Forward /						Disabled (0)				
RFC-A	⇕	Reverse (1), Reverse (2)					⇒					
RFC-S												

When a keypad is installed, this parameter enables the forward/reverse key.

00.024 {01.021} Preset Reference 1												
RW	Num										US	
OL		VM_SPEED_FREQ_						0.0 Hz / rpm				
RFC-A	⇕	REF Hz / rpm					⇒					
RFC-S												

00.029 {11.036} NV Media Card File Previously Loaded												
RO	Num							NC	PT			
OL		0 to 999						0				
RFC-A	⇕						⇒					
RFC-S												

This parameter shows the number of the data block last transferred from a NV Media Card to the drive.

00.030 {11.42} Parameter Cloning												
RW	Txt					NC		US*				
OL												
RFC-A	⇕	None (0), Read (1), Program (2), Auto (3), Boot (4)					⇒	None (0)				
RFC-S												

\* Only a value of 3 or 4 in this parameter is saved.

**NOTE**

If Pr **00.030** is equal to 1 or 2, this value is not transferred to the EEPROM or the drive. If Pr **00.030** is set to a 3 or 4 the value is transferred.

Pr String	Pr value	Comment
None	0	Inactive
Read	1	Read parameter set from the NV Media Card
Program	2	Programming a parameter set to the NV Media Card
Auto	3	Auto save
Boot	4	Boot mode

For further information, please refer to Chapter 8 *NV Media Card Operation* on page 99.

00.031 {11.033} Drive Rated Voltage												
RO	Txt					ND	NC	PT				
OL												
RFC-A	⇕	200 V (0), 400 V (1), 575 V (2), 690 V (3)					⇒					
RFC-S												

Pr **00.031** indicates the voltage rating of the drive.

00.032 {11.032} Maximum Heavy Duty Rating												
RO	Num					ND	NC	PT				
OL												
RFC-A	⇕	0.000 to 99999.999 A					⇒					
RFC-S												

Pr **00.032** indicates the maximum continuous Heavy Duty current rating.

00.033 {06.009} Catch A Spinning Motor (OL)												
00.033 {05.016} Rated Speed Optimization Select (RFC-A)												
RW	Txt									US		
OL	⇕	Disable (0), Enable (1), Fwd Only (2), Rev Only (3)					⇒	Disable (0)				
RFC-A	⇕	Disable (0), Classic slow (1), Classic fast (2), Combined (3), VARs only (4), Voltage only (5)					⇒	Disable (0)				

**Open-loop**

When the drive is enabled with Pr **00.033** = 0, the output frequency starts at zero and ramps to the required reference. When the drive is enabled when Pr **00.033** has a non-zero value, the drive performs a start-up test to determine the motor speed and then sets the initial output frequency to the synchronous frequency of the motor. Restrictions may be placed on the frequencies detected by the drive as follows:

Pr 00.033	Pr string	Function
0	Disable	Disabled
1	Enable	Detect all frequencies
2	Fwd only	Detect positive frequencies only
3	Rev only	Detect negative frequencies only

**RFC-A**

The motor rated full load rpm parameter (Pr **00.045**) in conjunction with the motor rated frequency parameter (Pr **00.046**) defines the full load slip of the motor. The slip is used in the motor model for closed-loop vector control. The full load slip of the motor varies with rotor resistance which can vary significantly with motor temperature. When Pr **00.033** is set to 1 or 2, the drive can automatically sense if the value of slip defined by Pr **00.045** and Pr **00.046** has been set incorrectly or has varied with motor temperature. If the value is incorrect parameter Pr **00.045** is automatically adjusted. The adjusted value in Pr **00.045** is not saved at power-down. If the new value is required at the next power-up it must be saved by the user.

Automatic optimization is only enabled when the speed is above 12.5 % of rated speed, and when the load on the motor load rises above 62.5 % rated load. Optimization is disabled again if the load falls below 50 % of rated load.

For best optimization results the correct values of stator resistance (Pr **05.017**), transient inductance (Pr **05.024**), stator inductance (Pr **05.025**) and saturation breakpoints (Pr **05.029**, Pr **05.030**) should be stored in the relevant parameters. These values can be obtained by the drive during an autotune (see Pr **00.040** for further details).

Rated rpm auto-tune is not available if the drive is not using external position/speed feedback.

The gain of the optimizer, and hence the speed with which it converges, can be set at a normal low level when Pr **00.033** is set to 1. If this parameter is set to 2 the gain is increased by a factor of 16 to give faster convergence.

00.034 {11.030} User security code												
RW	Num					ND	NC	PT	US			
OL												
RFC-A	⇕	0 to 2147483647					⇒	0				
RFC-S												

If any number other than 0 is programmed into this parameter, user security is applied so that no parameters except Pr **00.049** can be adjusted with the keypad. When this parameter is read via a keypad it appears as zero. For further details refer to section 5.9.3 *User Security Code* on page 36.

00.035 {11.024} Serial Mode	
RW	Txt
OL	8 2 NP (0), 8 1 NP (1), 8 1 EP (2), 8 1 OP (3), 8 2 NP M (4), 8 1 NP M (5), 8 1 EP M (6), 8 1 OP M (7), 7 2 NP (8), 7 1 NP (9), 7 1 EP (10), 7 1 OP (11), 7 2 NP M (12), 7 1 NP M (13), 7 1 EP M (14), 7 1 OP M (15)
RFC-A	
RFC-S	8 2 NP (0)

This parameter defines the communications protocol used by the EIA 485 comms port on the drive. This parameter can be changed via the drive keypad, via a Solutions Module or via the comms interface itself. If it is changed via the comms interface, the response to the command uses the original protocol. The master should wait at least 20 ms before send a new message using the new protocol. (Note: ANSI uses 7 data bits, 1 stop bit and even parity; Modbus RTU uses 8 data bits, 2 stops bits and no parity).

Pr Value	Pr String
0	8 2 NP
1	8 1 NP
2	8 1 EP
3	8 1 OP
4	8 2 NP M
5	8 1 NP M
6	8 1 EP M
7	8 1 OP M
8	7 2 NP
9	7 1 NP
10	7 1 EP
11	7 1 OP
12	7 2 NP M
13	7 1 NP M
14	7 1 EP M
15	7 1 OP M

The core drive always uses the Modbus rtu protocol and is always a slave. *Serial Mode Pr 00.035 {11.024}* defines the data format used by the serial comms interface. The bits in the value of *Serial Mode Pr 00.035 {11.024}* define the data format as follows. Bit 3 is always 0 in the core product as 8 data bits are required for Modbus rtu. The parameter value can be extended in derivative products which provide alternative communications protocols if required.

Bits	3	2	1 and 0
Format	Number of data bits 0 = 8 bits 1 = 7 bits	Register mode 0 = Standard 1 = Modified	Stop bits and Parity 0 = 2 stop bits, no parity 1 = 1 stop bit, no parity 2 = 1 stop bit, even parity 3 = 1 stop bit, odd parity

Bit 2 selects either standard or modified register mode. The menu and parameter numbers are derived for each mode as given in the following table. Standard mode is compatible with Unidrive SP. Modified mode is provided to allow register numbers up to 255 to be addressed. If any menus with numbers above 63 should contain more than 99 parameters, then these parameters cannot be accessed via Modbus rtu.

Register mode	Register address
Standard	(mm x 100) + ppp - 1 where mm ≤ 162 and ppp ≤ 99
Modified	(mm x 256) + ppp - 1 where mm ≤ 63 and ppp ≤ 255

Changing the parameters does not immediately change the serial communications settings. See *Reset Serial Communications Pr 00.052 {11.020}* for more details.

00.036 {11.025} Serial Baud Rate	
RW	Txt
OL	300 (0), 600 (1), 1200 (2), 2400 (3), 4800 (4), 9600 (5), 19200 (6), 38400 (7), 57600 (8), 76800 (9), 115200 (10)
RFC-A	
RFC-S	19200 (6)

This parameter can be changed via the drive keypad, via a Solutions Module or via the comms interface itself. If it is changed via the comms interface, the response to the command uses the original baud rate. The master should wait at least 20 ms before send a new message using the new baud rate.

00.037 {11.023} Serial Address	
RW	Num
OL	
RFC-A	1 to 247
RFC-S	1

Used to define the unique address for the drive for the serial interface. The drive is always a slave address 0 is used to globally address all slaves, and so this address should not be set in this parameter

00.038 {04.013} Current Controller Kp Gain	
RW	Num
OL	20
RFC-A	0 to 30000
RFC-S	150

00.039 {04.014} Current Controller Ki Gain	
RW	Num
OL	40
RFC-A	0 to 30000
RFC-S	2000

These parameters control the proportional and integral gains of the current controller used in the open loop drive. The current controller either provides current limits or closed loop torque control by modifying the drive output frequency. The control loop is also used in its torque mode during line power supply loss, or when the controlled mode standard ramp is active and the drive is decelerating, to regulate the flow of current into the drive.

00.040 {05.012}		Auto-tune											
RW	Num											NC	
OL	↕	0 to 2					⇒	0					
RFC-A	↕	0 to 5					⇒						
RFC-S	↕	0 to 6					⇒						

### Open-Loop

There are two autotune tests available in open loop mode, a stationary and a rotating test. A rotating autotune should be used whenever possible so the measured value of power factor of the motor is used by the drive.

#### Autotune test 1:

- A stationary autotune can be used when the motor is loaded and it is not possible to remove the load from the motor shaft. The stationary test measures the *Stator Resistance (05.017)*, *Transient Inductance (05.024)*, *Maximum Deadtime Compensation (05.059)* and current at *Maximum Deadtime Compensation (05.060)* which are required for good performance in vector control modes (see Open Loop Control Mode (00.007), later in this table). If *Enable Stator Compensation (05.049) = 1*, then *Stator Base Temperature (05.048)* is made equal to *Stator Temperature (05.046)*. The stationary autotune does not measure the power factor of the motor so the value on the motor nameplate must be entered into Pr 00.043. To perform a Stationary autotune, set Pr 00.040 to 1, and provide the drive with both an enable signal (on terminal 31) and a run signal (on terminal 26 or 27).

#### Autotune test 2:

- A rotating autotune should only be used if the motor is unloaded. A rotating autotune first performs a stationary autotune, as above, then a rotating test is performed in which the motor is accelerated with currently selected ramps up to a frequency of *Rated Frequency (Pr 00.047 {05.006})*  $\times \frac{2}{3}$ , and the frequency is maintained at that level for 4 seconds. *Stator Inductance (05.025)* is measured and this value is used in conjunction with other motor parameters to calculate *Rated Power Factor (05.010)*. To perform a Rotating autotune, set Pr 00.040 to 2, and provide the drive with both an enable signal (on terminal 31) and a run signal (on terminal 26 or 27).

Following the completion of an autotune test the drive will go into the inhibit state. The drive must be placed into a controlled disable condition before the drive can be made to run at the required reference. The drive can be put in to a controlled disable condition by removing the Safe Torque Off signal from terminal 31, setting the *Drive Enable (06.015)* to Off (0) or disabling the drive via the *Control Word (06.042)* and *Control Word Enable (06.043)*.

### RFC-A

There are five autotune tests available in RFC-A sensorless mode, a stationary test, a rotating test and two inertia measurement tests. A stationary autotune will give moderate performance whereas a rotating autotune will give improved performance as it measures the actual values of the motor parameters required by the drive. An inertia measurement test should be performed separately to a stationary or rotating autotune see Optimization section for further details.

It is highly recommended that a rotating autotune is performed (Pr 00.040 set to 2).

#### Autotune test 1:

- A stationary autotune can be used when the motor is loaded and it is not possible to remove the load from the motor shaft. The stationary autotune measures the *Stator Resistance (05.017)* and *Transient*

*Inductance (05.024)* of the motor. These are used to calculate the current loop gains, and at the end of the test the values in Pr 00.038 {04.013} and Pr 00.039 {04.014} are updated. *Maximum Deadtime Compensation (05.059)* and *Current At Maximum Deadtime Compensation (05.060)* for the drive are also measured. Additionally, if *Enable Stator Compensation (05.049) = 1*, then *Stator Base Temperature (05.048)* is made equal to *Stator Temperature (05.046)*. A stationary autotune does not measure the power factor of the motor so the value on the motor nameplate must be entered into Pr 00.043.

To perform a Stationary autotune, set Pr 00.040 to 1, and provide the drive with both an enable signal (on terminal 31) and a run signal (on terminal 26 or 27).

#### Autotune test 2:

- A rotating autotune should only be used if the motor is unloaded. A rotating autotune first performs a stationary autotune, a rotating test is then performed which the motor is accelerated with currently selected ramps up to a frequency of *Rated Frequency Pr 00.047 {05.006}*  $\times \frac{2}{3}$ , and the frequency is maintained at the level for up to 40 s. During the rotating autotune the *Stator Inductance (05.025)*, and the motor saturation breakpoints (Pr 05.029, Pr 05.030, Pr 06.062 and Pr 05.063) are modified by the drive. The *Rated Power Factor (Pr 05.010)* is also modified by the *Stator Inductance (05.035)*. To perform a Rotating autotune, set Pr 00.040 to 2, and provide the drive with both an enable signal (on terminal 31) and a run signal (on terminal 26 or 27).

Following the completion of an autotune test, the drive will go into the inhibit state. The drive must be placed into a controlled disable condition before the drive can be made to run at the required reference. The drive can be put in to a controlled disable condition by removing the Safe Torque Off signal from terminal 31, setting the *Drive Enable (06.015)* to Off (0) or disabling the drive via the control word (Pr 06.042 & Pr 06.043).

### RFC-S

There are six autotune tests available in RFC-S sensorless mode, a stationary autotune and two inertia measurement tests. Please see Optimization section for further details on the inertia tests.

#### Autotune test 1:

- The stationary autotune can be used to measure all the necessary parameters for basic control. The tests measures *Stator Resistance (05.017)*, *Ld (05.024)*, *No Load Lq Pr 00.056 {05.072}*, *Maximum Deadtime Compensation (05.059)* and *Current At Maximum Deadtime Compensation (05.060)*. If *Enable Stator Compensation (05.049) = 1* then *Stator Base Temperature (05.048)* is made equal to *Stator Temperature (05.046)*. The *Stator Resistance (05.017)* and the *Ld (05.024)* are then used to set up *Current controller Kp Gain Pr 00.038 {04.013}* and *Current Controller Ki Gain Pr 00.039 {04.014}*. To perform a Stationary autotune, set Pr 00.040 to 1, and provide the drive with both an enable signal (on terminal 31) and a run signal (on terminal 26 or 27).

#### Autotune test 2:

- In sensorless mode, if Rotating autotune is selected (Pr 00.040 = 2), then a stationary autotune is performed.

Following the completion of an autotune test the drive will go into the inhibit state. The drive must be placed into a controlled disable condition before the drive can be made to run at the required reference. The drive can be put in to a controlled disable condition by removing the Safe Torque Off signal from terminal 31, setting the drive *Enable Parameter (06.015)* to Off (0) or disabling the drive via the control word (Pr 06.042 & Pr 06.043).

00.041 {05.018}		Maximum Switching Frequency					
RW	Txt			RA	NC		
OL	↕	2 (0) kHz, 3 (1) kHz, 4 (2) kHz, 6 (3) kHz, 8 (4) kHz, 12 (5) kHz, 16 (6) kHz		⇒	3 (1) kHz		
RFC-A							
RFC-S							

This parameter defines the required switching frequency. The drive may automatically reduce the actual switching frequency (without changing this parameter) if the power stage becomes too hot. A thermal model of the IGBT junction temperature is used based on the heatsink temperature and an instantaneous temperature drop using the drive output current and switching frequency. The estimated IGBT junction temperature is displayed in Pr **07.034**. If the temperature exceeds 135 °C the switching frequency is reduced if this is possible (i.e >3 kHz). Reducing the switching frequency reduces the drive losses and the junction temperature displayed in Pr **07.034** also reduces. If the load condition persists the junction temperature may continue to rise again above 145 °C and the drive cannot reduce the switching frequency further the drive will initiate an 'Oht Inverter' trip. Every second the drive will attempt to restore the switching frequency to the level set in Pr **00.041**.

The full range of switching frequencies is not available on all ratings of Unidrive M. See section 7.5 *Switching frequency* on page 90 for the maximum available switching frequency for each drive rating.

### 6.3.7 Motor parameters

00.042 {05.011}		Number Of Motor Poles					
RW	Num						US
OL	↕	Automatic (0) to 480 Poles (240)		⇒	Automatic (0)		
RFC-A							
RFC-S				⇒	8 Poles (4)		

#### Open-loop

This parameter is used in the calculation of motor speed, and in applying the correct slip compensation. When Automatic (0) is selected, the number of motor poles is automatically calculated from the *Rated Frequency* (00.047) and the *Rated Speed* rpm (00.045). The number of poles = 120 \* rated frequency / rpm rounded to the nearest even number.

#### RFC-A

This parameter must be set correctly for the vector control algorithms to operate correctly. When Automatic (0) is selected, the number of motor poles is automatically calculated from the *Rated Frequency* (00.047) and the *Rated Speed* rpm (00.045) rpm. The number of poles = 120 \* rated frequency / rpm rounded to the nearest even number.

#### RFC-S

This parameter must be set correctly for the vector control algorithms to operate correctly. When Automatic (0) is selected the number of poles is set to 6.

00.043 {05.010}		Rated Power Factor					
RW	Num						US
OL	↕	0.000 to 1.000		⇒	0.850		
RFC-A	↕	0.000 to 1.000		⇒	0.850		
RFC-S	↕			⇒			

The power factor is the true power factor of the motor, i.e. the angle between the motor voltage and current.

#### Open-loop

The power factor is used in conjunction with the motor rated current (Pr **00.046**) to calculate the rated active current and magnetizing current of the motor. The rated active current is used extensively to control the drive, and the magnetizing current is used in vector mode Rs compensation. It is important that this parameter is set up correctly.

This parameter is obtained by the drive during a rotational autotune. If a stationary autotune is carried out, then the nameplate value should be entered in Pr **00.043**.

#### RFC-A

If the stator inductance (Pr **05.025**) contains a non-zero value, the power factor used by the drive is continuously calculated and used in the vector control algorithms (this will not update Pr **00.043**).

If the stator inductance is set to zero (Pr **05.025**) then the power factor written in Pr **00.043** is used in conjunction with the motor rated current and other motor parameters to calculate the rated active and magnetizing currents which are used in the vector control algorithm.

This parameter is obtained by the drive during a rotational autotune. If a stationary autotune is carried out, then the nameplate value should be entered in Pr **00.043**.

#### NOTE

Following a rotating autotune Pr **00.043** {05.010} is continuously written by the drive, calculated from the value of Stator Inductance (Pr **05.025**). To manually enter a value into Pr **00.043** {05.010}, Pr **05.025** will need to be set to 0. Please refer to the description of Pr **05.010** in the *Parameter Reference Guide* for further details

00.044 {05.009}		Rated Voltage					
RW	Num			RA			US
OL	↕	0 to		⇒	200 V drive: 230 V		
RFC-A		VM_AC_VOLTAGE_S			50Hz default 400 V drive: 400 V		
RFC-S		ET			60Hz default 400 V drive: 460 V 575 V drive: 575 V 690 V drive: 690 V		

Enter the value from the rating plate of the motor.

00.045 {05.008}		Rated Speed					
RW	Num			ND			US
OL	↕	0 to 33000 rpm		⇒	50 Hz default: 1500 rpm 60 Hz default: 1800 rpm		
RFC-A	↕	0.00 to 33000.00 rpm		⇒	50 Hz default: 1450.00 rpm 60 Hz default: 1750.00 rpm		
RFC-S	↕	0.00 to 33000.00 rpm		⇒	3000.00 rpm		

#### Open-loop

This is the speed at which the motor would rotate when supplied with its base frequency at rated voltage, under rated load conditions (= synchronous speed - slip speed). Entering the correct value into this parameter allows the drive to increase the output frequency as a function of load in order to compensate for this speed drop.

Slip compensation is disabled if Pr **00.045** is set to 0 or to synchronous speed, or if Pr **05.027** is set to 0.

If slip compensation is required this parameter should be set to the value from the rating plate of the motor, which should give the correct rpm for a hot machine. Sometimes it will be necessary to adjust this when the drive is commissioned because the nameplate value may be inaccurate. Slip compensation will operate correctly both below base speed and within the field weakening region. Slip compensation is normally used to correct for the motor speed to prevent speed variation with load. The rated load rpm can be set higher than synchronous speed to deliberately introduce speed droop. This can be useful to aid load sharing with mechanically coupled motors.

### RFC-A

Rated speed is used with motor rated frequency to determine the full load slip of the motor which is used by the vector control algorithm. Incorrect setting of this parameter can result in the following:

- Reduced efficiency of motor operation
- Reduction of maximum torque available from the motor
- Failure to reach maximum speed
- Over-current trips
- Reduced transient performance
- Inaccurate control of absolute torque in torque control modes

The nameplate value is normally the value for a hot machine, however, some adjustment may be required when the drive is commissioned if the nameplate value is inaccurate. The rated full load rpm can be optimized by the drive (For further information, refer to section 7.1.2 *RFC-A Mode* on page 80).

### RFC-S

The rated speed used as follows:

- Operation without position feedback i.e. sensorless Mode Active (Pr **03.078**)= 1
- Where the motor operates above this speed and flux weakening is active
- In the motor thermal model

00.046 {05.007} Rated Current	
RW	Num
OL	↕
RFC-A	↕
RFC-S	↕
	0.000 to VM_RATED_CURRENT ⇒ Maximum Heavy Duty Rating Pr 00.032 {11.032}

Enter the name-plate value for the motor rated current.

00.047 {05.006} Rated Frequency (OL, RFC-A)	
00.047 {05.033} Volts per 1000 rpm (RFC-S)	
RW	Num
OL	↕
RFC-A	↕
RFC-S	↕
	0.0 to 550.0 Hz ⇒ 50 Hz default: 50.0 Hz 60 Hz default: 60.0 Hz
	0 to 10000 V / 1000 rpm ⇒ 98 V / 1000 rpm

Enter the value from the rating plate of the motor.

### 6.3.8 Operating-mode selection

00.048 {11.031} User Drive Mode	
RW	Txt
OL	⇒
RFC-A	↕
RFC-S	↕
	Open-loop (1), RFC-A (2), RFC-S (3), Regen (4) ⇒ Open-loop (1) ⇒ RFC-A (2) ⇒ RFC-S (3)

The settings for Pr **00.048** are as follows:

Setting	Operating mode
1	Open-loop
2	RFC-A
3	RFC-S
4	Regen

This parameter defines the drive operating mode. Pr **mm.000** must be set to '1253' (European defaults) or '1254' (USA defaults) before this parameter can be changed. When the drive is reset to implement any change in this parameter, the default settings of all parameters will be set according to the drive operating mode selected and saved in memory.

### 6.3.9 Status information

00.049 {11.044} User Security Status	
RW	Txt
OL	⇒
RFC-A	↕
RFC-S	↕
	Menu 0 (0), All Menus (1), Read-only Menu 0 (2), Read-only (3), Status Only (4), No Access (5) ⇒ Menu 0 (0)

This parameter controls access via the drive keypad as follows:

Security level	Description
0 (Menu 0)	All writable parameters are available to be edited but only parameters in Menu 0 are visible.
1 (All Menus)	All writable parameters are visible and available to be edited.
2 (Read-only Menu 0)	All parameters are read-only. Access is limited to Menu 0 parameters only.
3 (Read-only)	All parameters are read-only however all menus and parameters are visible.
4 (Status Only)	The keypad remains in status mode and no parameters can be viewed or edited.
5 (No Access)	The keypad remains in status mode and no parameters can be viewed or edited. Drive parameters cannot be accessed via a comms / fieldbus interface in the drive or any option module.

The keypad can adjust this parameter even when user security is set.

00.050 {11.029} Software Version	
RO	Num
OL	⇒
RFC-A	↕
RFC-S	↕
	0 to 99999999 ⇒

The parameter displays the software version of the drive.

00.051 {10.037} Action On Trip Detection	
RW	Bin
OL	⇒
RFC-A	↕
RFC-S	↕
	00000 to 11111 ⇒ 00000

Each bit in this parameter has the following functions:

Bit	Function
0	Stop on non-important trips
1	Disable braking resistor overload detection
2	Disable phase loss stop
3	Disable braking resistor temperature monitoring
4	Disable parameter freeze on trip

#### Example

Pr **00.051 {10.037}** = 8 (1000<sub>binary</sub>) Th Brake Res trip is disabled

Pr **00.051 {10.037}** = 12 (1100<sub>binary</sub>) Th Brake Res and phase loss trip is disabled

#### Stop on non-important trips

If bit 0 is set to one the drive will attempt to stop before tripping if any of the following trip conditions are detected: I/O Overload, An Input 1 Loss, An Input 2 Loss or Keypad Mode.

#### Disable braking resistor overload detection

For details of braking resistor overload detection mode see Pr **10.030**.

#### Disable phase loss trip

Normally the drive will stop when the input phase loss condition is detected. If this bit is set to 1 the drive will continue to run and will only trip when the drive is brought to a stop by the user.

#### Disable braking resistor temperature monitoring

Size 3, 4 and 5 drives have an internal user install braking resistor with a thermistor to detect overheating of the resistor. As default bit 3 of Pr **00.051 {10.037}** is set to zero, and so if the braking resistor and its thermistor is not installed the drive will produce a trip (Th Brake Res) because the thermistor appears to be open-circuit. This trip can be disabled so that the drive can run by setting bit 3 of Pr **00.051 {10.037}** to one. If the resistor is installed then no trip is produced unless the thermistor fails, and so bit 3 of Pr **00.051 {10.037}** can be left at zero. This feature only applies to size 3, 4 and 5 drives. For example if Pr **00.051 {10.037}** = 8, then Th Brake Res trip will be disabled.

#### Disable parameter freeze on trip

If this bit is 0 then the parameters listed below are frozen on trip until the trip is cleared. If this bit is 1 then this feature is disabled.

Open-loop mode	RFC-A and RFC-S modes
Reference Selected (01.001)	Reference Selected (01.001)
Pre-skip Filter Reference (01.002)	Pre-skip Filter Reference (01.002)
Pre-ramp Reference (01.003)	Pre-ramp Reference (01.003)
Post Ramp Reference (02.001)	Post Ramp Reference (02.001)
	Final Speed Reference (03.001)
	Speed Feedback Pr 00.010 {03.002}
	Speed Error (03.003)
	Speed Controller Output (03.004)
Current Magnitude Pr 00.012 {04.001}	Current Magnitude Pr 00.012 {04.001}
Torque Producing Current Pr 00.013 {04.002}	Torque Producing Current Pr 00.013 {04.002}
Magnetising Current (04.017)	Magnetising Current (04.017)
Output Frequency Pr 00.011 {05.001}	Output Frequency Pr 00.011 {05.001}
Output Voltage (05.002)	Output Voltage (05.002)
Output Power (05.003)	Output Power (05.003)
D.c. Bus Voltage (05.005)	D.c. Bus Voltage (05.005)
Analog Input 1 (07.001)*	Analog Input 1 (07.001)*
Analog Input 2 (07.002)*	Analog Input 2 (07.002)*
Analog Input 3 (07.003)*	Analog Input 3 (07.003)*

\*Not applicable to Unidrive M702

00.052 {11.020} Reset Serial Communications	
RW	Bit
OL	
RFC-A	⇕
RFC-S	⇕

Off (0) or On (1) ⇔ Off (0)

When *Serial Address* Pr **00.037 {11.023}**, *Serial Mode* Pr **00.035 {11.024}**, *Serial Baud Rate* Pr **00.036 {11.025}**, *Minimum Comms Transmit Delay* (11.026) or *Silent Period* (11.027) are modified the changes do not have an immediate effect on the serial communications system. The new values are used after the next power-up or if *Reset Serial Communications* Pr **00.052 {11.020}** is set to one. *Reset Serial Communications* Pr **00.052 {11.020}** is automatically cleared to zero after the communications system is updated.

00.053 {04.015} Motor Thermal Time Constant	
RW	Num
OL	
RFC-A	⇕
RFC-S	⇕

1.0 to 3000.0 s ⇔ 89.0 s

Pr **00.053** is the motor thermal time constant of the motor, and is used (along with the motor rated current Pr **00.046**, and total motor current Pr **00.012**) in the thermal model of the motor in applying thermal protection to the motor.

Setting this parameter to 0 disables the motor thermal protection.

For further details, refer to section 7.4 *Motor thermal protection* on page 89.

### 6.3.10 Additional parameters for RFC-S sensorless control

00.054 {05.064} RFC Low Speed Mode	
RW	Txt
OL	
RFC-A	⇕
RFC-S	⇕

Injection (0), Non salient (1) Current (2), Current No Test (3) ⇔ Non salient (1)

If sensorless mode is being used and is active (i.e. *Sensorless Mode Active* (03.078) = 1) and the motor speed is below *Rated Speed* (00.045) / 10 then a special low speed algorithm must be used to control the motor. *RFC Low Speed Mode* (00.054) is used to select the algorithm to be used.

#### 0: Injection

A high frequency signal is injected into the motor to detect the motor flux axis. This can be used in a similar way to operation with position feedback except that for the drive to remain stable the speed controller bandwidth may need to be limited to 10 Hz or less and the current limit may need to be limited (see *Low Speed Sensorless Mode Current* (00.055)).

#### 1: Non-salient

If the ratio  $Lq/Ld < 1.1$  on no load then the injection mode cannot be used and this mode should be used instead. This mode does not provide the same level of control as injection mode and has the following restrictions:

- Speed control is possible, but not torque control.
- Spinning start is not possible and the motor must start from standstill.
- Below *Rated Speed* (00.045) / 10 it will not be possible to produce more than approximately 60 % to 70 % of rated torque.

- There may be some movement of the motor shaft in either direction as the motor starts.
- It is not possible to measure the motor inertia using auto-tuning with *Auto-tune* (00.040) = 4.
- Normally the ramp rate should not be slower than 5 s/1000 rpm when operating in the region below *Rated Speed* (00.045) / 10.
- This mode is not intended to control the motor for prolonged periods below *Rated Speed* (00.045) / 10, but is intended to allow the motor to be started from standstill to run outside the low speed region.
- This mode is not intended to allow motor reversals. If the direction does need to be reversed, the motor should be stopped and any oscillations must die away, before the motor is restarted in the other direction.

*Low Speed Sensorless Mode Current* (00.055) defines a current applied in the motor d axis to aid starting. The default value is suitable for most motors with a load of up to 60% rated torque. However, in some applications this level may need to be adjusted.

### 2: Current

This method, which applies a rotating current vector at the frequency defined by the speed reference, can be used with any motor with no saliency or moderate saliency. It should only be used with motors where more of the torque is produced in conjunction with the magnet flux rather than from saliency torque. This mode does not provide the same level of control at low speed as injection mode, but is easier to set up and more flexible than "Non-salient" mode. The following should be considered:

1. Only speed control can be used when low speed mode operation is active.
2. A current specified by *Low Speed Sensorless Mode Current* (00.055) is applied when low speed mode is active. This current should be sufficient to start the motor with the highest expected load. If the motor has some saliency with no-load applied, and a suitable saturation characteristic, the drive can detect the rotor position and apply the current at the correct angle to avoid starting transient. If the motor is non-salient as defined by the conditions for *Inductance trip* then the drive will not attempt to detect the rotor position and the current will be applied at an arbitrary angle. This could cause a starting transient if the level of current applied is high, and so *Low Speed Sensorless Mode Current* (00.055) should not be set to a higher level than necessary. To minimise the movement as a result of applying the current, it is increased over the period defined by *Sensorless Mode Current Ramp* (05.063) in the form of a squared characteristic (i.e. it is increased with a low rate of change at the beginning and the rate of change is gradually increased).
3. It is not possible to measure the motor inertia using auto-tuning with *Auto-tune* (00.040) = 4.
4. As the level of current when low speed mode is active is not dependent on the applied load, but is as defined by *Low Speed Sensorless Mode Current* (00.055), and so the motor may become too hot if low speed mode is active for a prolonged period of time.
5. Generally *Low Speed Sensorless Mode Current* (00.055) should be set to a level higher than the expected maximum load, and can be set to a much higher level than the load if the saliency and saturation characteristic allow the position of the rotor to be detected on starting. However, *Low Speed Sensorless Mode Current* (00.055) should be matched more closely to the expected load under the following conditions: the load inertia is high compared to the motor inertia, or there is very little damping/loss in the load system, or where the q axis inductance of the motor changes significantly with load.

### 3: Current no test

The "Current" method is used, but no attempt is made to determine the position of the rotor before applying the current. This can be selected for example, if the motor does not have a suitable saturation characteristic to allow the rotor position to be determined during starting, or if faster starting is required. The initial current vector angle will be at an arbitrary position with respect to the actual rotor position. As the vector sweeps round it must make the rotor start to rotate. If the ramp rate is too high the rotor may not keep up with the current vector and the motor may not

start. If this is the case then the ramp rate should be reduced and/or the current used to start the motor should be increased.

Torque control can be used with the "Injection" starting method in the same way as with position feedback. However if torque control is to be used in an application where the other starting methods are used then the following should be considered:

1. Torque control should not be enabled until the low speed algorithm is no longer active and the motor speed must not drop to a level where the low speed mode will become active again while torque control is active. This means that the motor must be started in speed control and torque control should only be selected when the speed is high enough.
2. To stop the motor the drive can simply be disabled or the run should be removed for the drive to stop the motor. Removing the run causes the drive to switch from torque control to speed control, and so the motor speed can be reduced back down through the range where the low speed algorithm is active.

00.055 {05.071} Low Speed Sensorless Mode Current Limit		RW	Num	RA	US
OL	⇕			⇒	
RFC-A					
RFC-S	⇕		0.0 to 1000.0 %	⇒	20.0 %

### Injection mode

For low speed sensorless operation with signal injection (*RFC Low Speed Mode* (00.054) = 0) it is necessary to have a ratio of  $L_q/L_d = 1.1$ . Even if a motor has a larger ratio on no load, this ratio normally reduces as the q axis current is increased from zero. *Low Speed Sensorless Mode Current Limit* (00.055) should be set at a level that is lower than the point where the inductance ratio falls to 1.1. The value of this parameter is used to define the drive current limits when signal injection is active and prevent loss of control of the motor.

### Non-salient mode

For low speed sensorless operation for non-salient motors (*RFC Low Speed Mode* (00.054) = 1) defines a current applied in the d axis to aid starting. For most motors and applications requiring up to 60 % torque on starting, the default value is suitable. However the level of current may need to be increased to make the motor start.

00.056 {05.072} No-load Lq		RW	Num	RA	US
OL	⇕			⇒	
RFC-A					
RFC-S	⇕		0.0000 to 500.000 mH		0.000 mH

Motor q axis inductance with no current in the motor.

00.057 {05.075} Iq Test Current For Inductance Measurement		RW	Num	RA	US
OL	⇕			⇒	
RFC-A					
RFC-S	⇕		0 to 200 %	⇒	100 %

Maximum test current level used for Iq during auto-tuning when measuring the motor inductance and phase offset as a percentage of *Rated Current* (00.046). This value is also used by the sensorless control algorithm to define the motor inductance and a reference frame phase offset at different levels of Iq. The values of *Lq At The Defined Iq Test Current* (00.059), and *Phase Offset At Iq Test Current* (00.058), should be the values which correspond to the test current level. For most

motors, *Phase Offset At Iq Test Current* (00.058) will be zero and have little effect on the performance, however Lq is likely to vary significantly with Iq and should be set up correctly for good performance. If *Lq At The Defined Iq Test Current* (00.059), or *Iq Test Current For Inductance Measurement* (00.057) are zero, then the estimate of Lq will not be affected by the level of Iq, and if *Phase Offset At Iq Test Current* (00.058) or *Iq Test Current For Inductance Measurement* (00.057) are zero the phase offset will not be affected by the level of Iq.

00.058 {05.077} Phase Offset At Iq Test Current	
RW	Num
OL	↕
RFC-A	⇒
RFC-S	↕ ±90.0 ° ⇒ 0.0 °

This parameter defines the offset of the point of minimum inductance as an electrical angle from the point with no current in the motor, to the point with a level of Iq equivalent to *Iq Test Current For Inductance Measurement* (00.057). When the value is left at its default value of zero, no compensation for phase offset with changes in Iq are made. *Phase Offset At Iq Test Current* (00.058) is used for low speed RFC sensorless control using injection mode. A positive value advances the point of minimum inductance with positive Iq. See *RFC Low Speed Mode* (00.054). For most motors a value of zero is acceptable.

00.059 {05.078} Lq At The Defined Iq Test Current	
RW	Num
OL	↕
RFC-A	⇒
RFC-S	↕ 0.000 to 500.000 mH ⇒ 0.000 mH

Motor q axis inductance with no current in the d axis and the current defined by *Iq Test Current For Inductance Measurement* (00.057) in the q axis of the motor. If this parameter is left at its default value of zero, then no compensation is made to the value of Lq with changes in Iq.

00.060 {05.082} Id Test Current For Inductance Measurement	
RW	Num
OL	↕
RFC-A	⇒
RFC-S	↕ -100 to 0 % ⇒ - 50 %

Minimum test current level used for Id during auto-tuning when measuring the motor inductance as a percentage of *Rated Current* (00.046). This is then used in a similar way as *Iq Test Current For Inductance Measurement* (00.057), to estimate the value of Lq used in the control algorithms as Id changes. If *Lq At The Defined Id Test Current* (00.061), or *Id Test Current for Inductance Measurement* (00.060) are set to zero, then no compensation is made for changes in Lq with Id.

00.061 {05.084} Lq At The Id Test Current	
RW	Num
OL	↕
RFC-A	⇒
RFC-S	↕ 0.000 to 500.000 mH ⇒ 0.000 mH

Motor q axis inductance with no current in the q axis and the current defined by *Id Test Current for Inductance Measurement* (00.060) in the d axis of the motor. If this parameter is left at its default value of zero then no compensation is made to the value of Lq with changes in Id.

## 6 Running the motor

This chapter takes the new user through all the essential steps to running a motor for the first time, in each of the possible operating modes.

For information on tuning the drive for the best performance, see *Chapter 7 Optimization* on page 77.



Ensure that no damage or safety hazard could arise from the motor starting unexpectedly.

**WARNING**



The values of the motor parameters affect the protection of the motor. The default values in the drive should not be relied upon. It is essential that the correct value is entered in Pr **00.046 Rated Current**. This affects the thermal protection of the motor.

**CAUTION**



If the drive is started using the keypad it will run to the speed defined by the keypad reference (Pr **01.017**). This may not be acceptable depending on the application. The user must check in Pr **01.017** and ensure that the keypad reference has been set to 0.

**CAUTION**



If the intended maximum speed affects the safety of the machinery, additional independent over-speed protection must be used.

**WARNING**

### 6.1 Quick start connections

#### 6.1.1 Basic requirements

This section shows the basic connections which must be made for the drive to run in the required mode. For minimal parameter settings to run in each mode please see the relevant part of section 6.3 *Quick start commissioning / start-up* on page 64.

**Table 6-1 Minimum control connection requirements for each control mode**

Drive control method	Requirements
Terminal mode	Drive enable Speed / Torque reference Run forward / Run reverse
Keypad mode	Drive enable
Serial communications	Drive enable Serial communications link

**Table 6-2 Minimum requirements for each mode of operation**

Operating mode	Requirements
Open loop mode	Induction motor
RFC – A sensorless (without feedback position)	Induction motor without speed feedback
RFC - S sensorless (without position feedback)	Permanent magnet motor without speed and position feedback

### 6.2 Changing the operating mode

Changing the operating mode returns all parameters to their default value, including the motor parameters. *User Security Status* (Pr **00.049**) and *User Security Code* (Pr **00.034**) are not affected by this procedure).

#### Procedure

Use the following procedure only if a different operating mode is required:

- Enter either of the following values in Pr **mm.000**, as appropriate:  
1253 (50 Hz AC supply frequency)  
1254 (60 Hz AC supply frequency)
- Change the setting of Pr **00.048** as follows:

Pr 00.048 setting		Operating mode
	1	Open-loop
	2	RFC-A
	3	RFC-S

The figures in the second column apply when serial communications are used.

3. Either:

- Press the red reset button
- Toggle the reset digital input
- Carry out a drive reset through serial communications by setting Pr **10.038** to 100 (ensure that Pr. **mm.000** returns to 0).

**Figure 6-1 Minimum connections to get the motor running in any operating mode (size 3 and 4)**

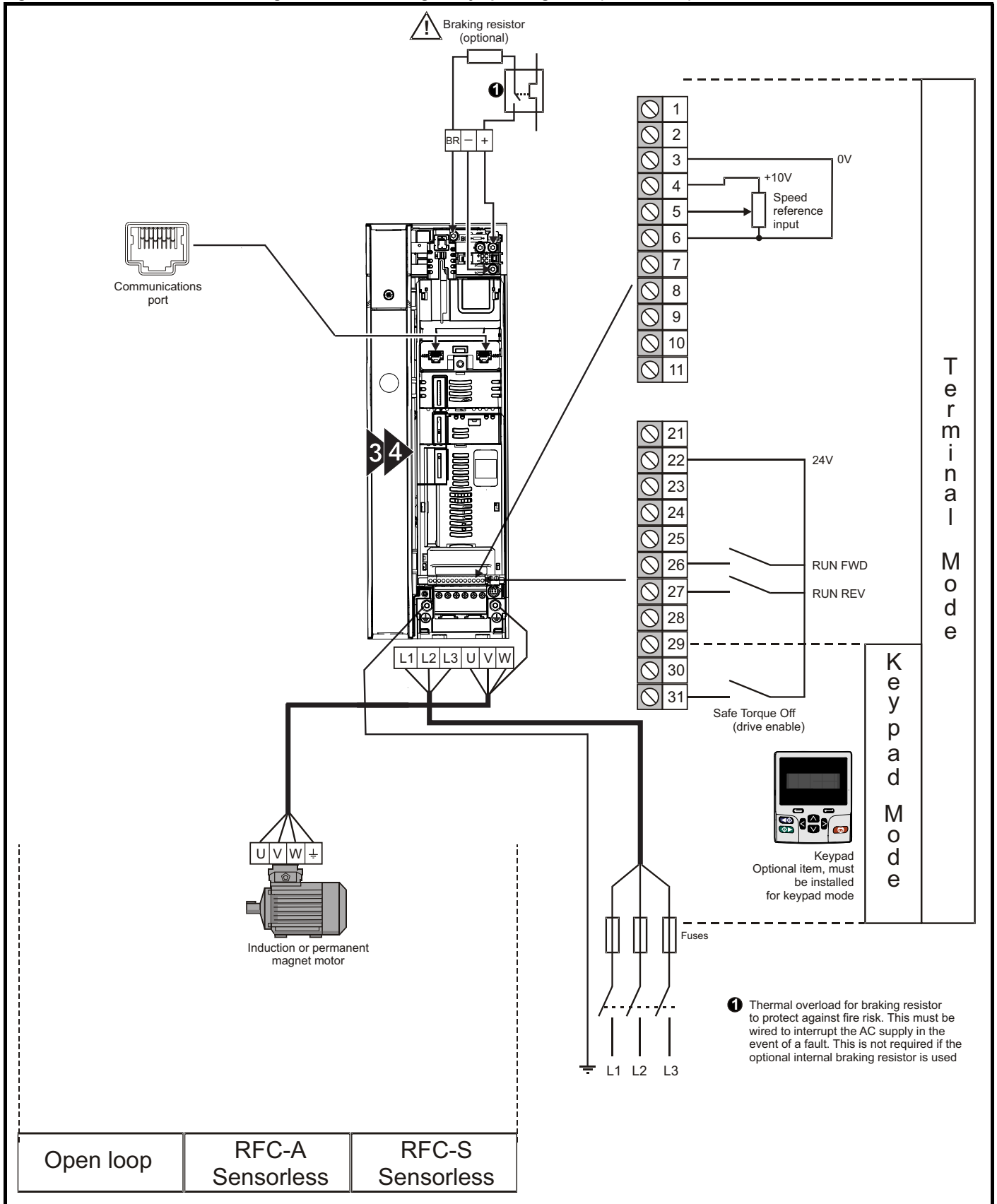

**Figure 6-2 Minimum connections to get the motor running in any operating mode (size 5)**

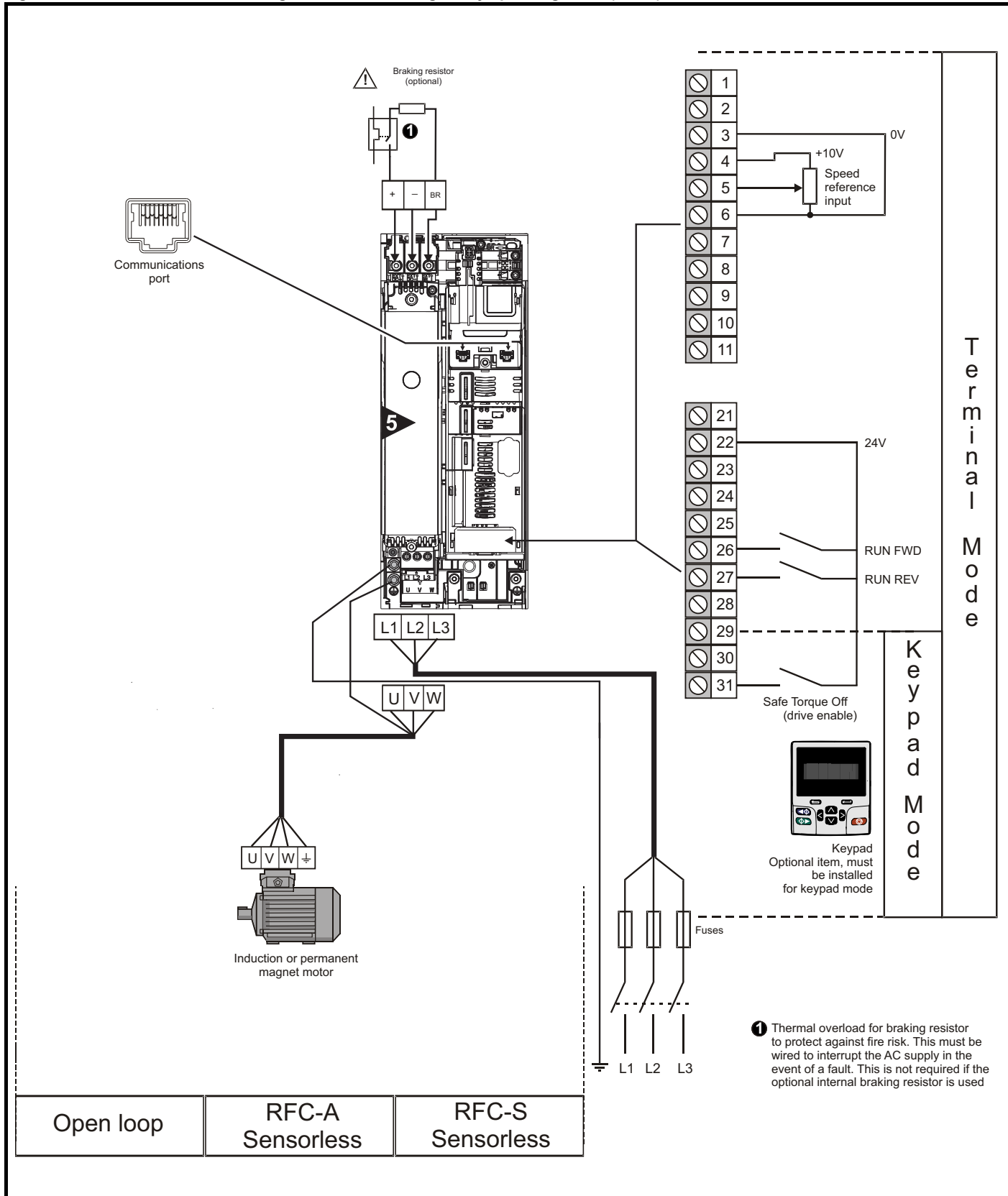

**Figure 6-3 Minimum connections to get the motor running in any operating mode (size 6)**

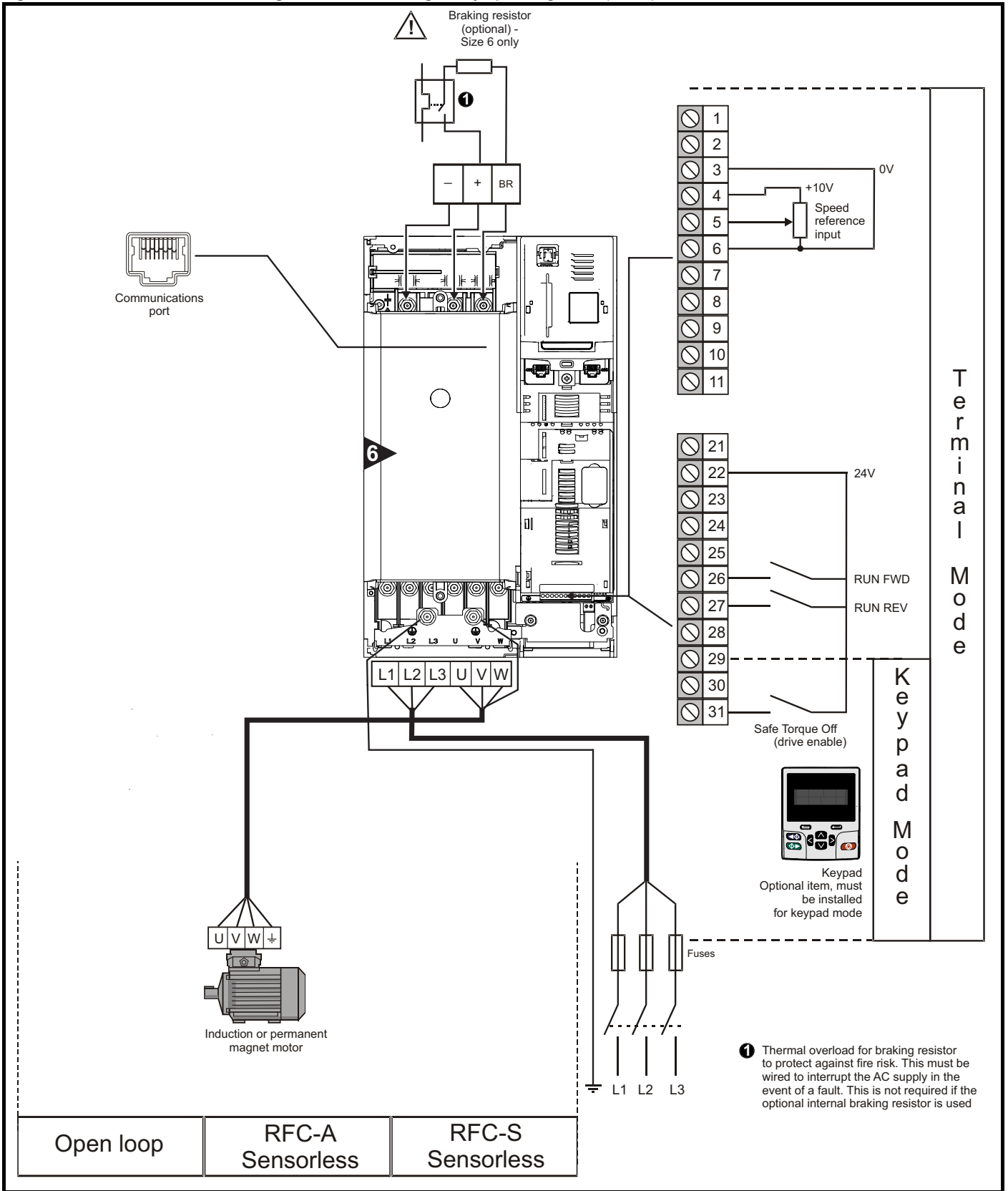

**Figure 6-4 Minimum connections to get the motor running in any operating mode (size 7 onwards)**

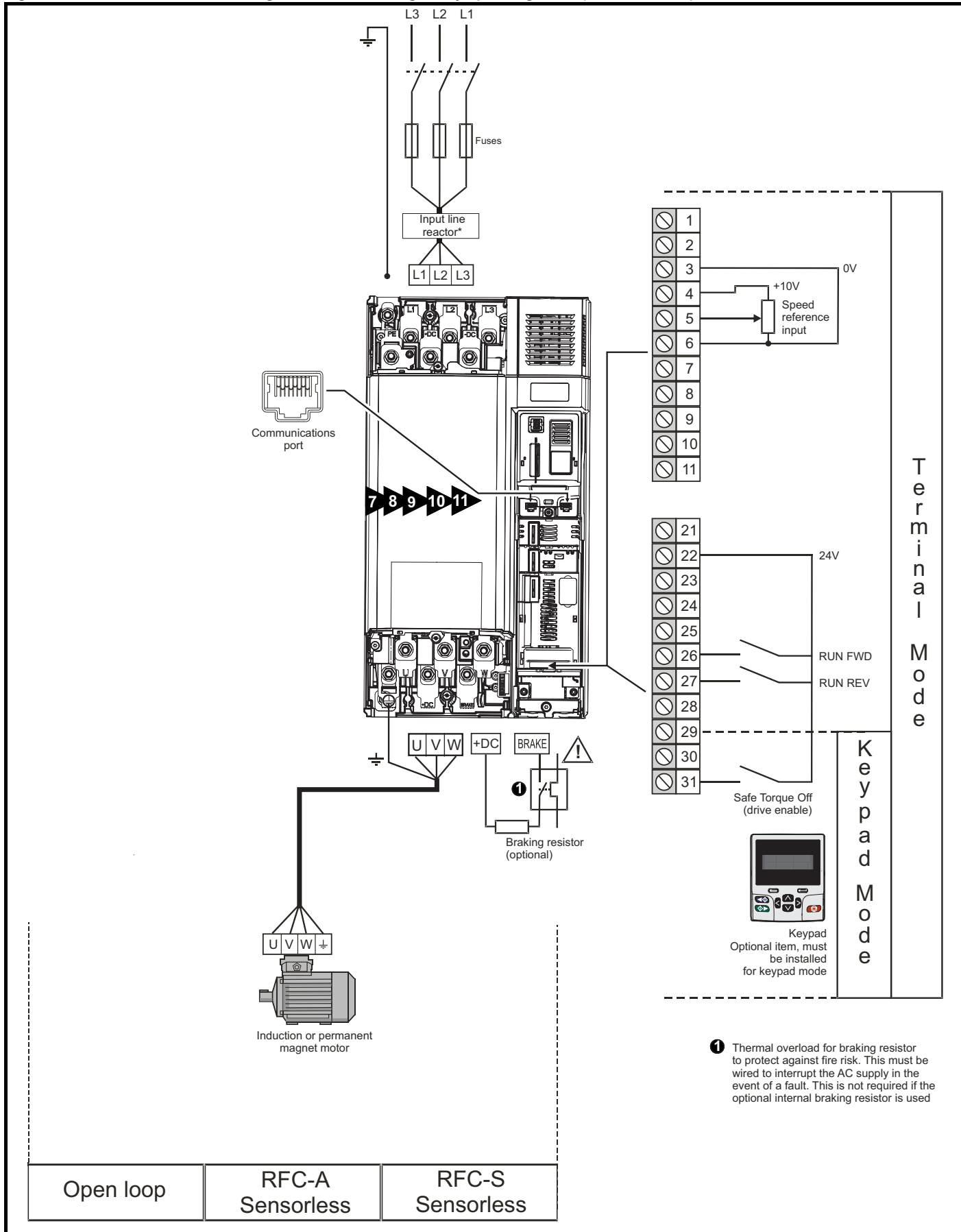

**1** Thermal overload for braking resistor to protect against fire risk. This must be wired to interrupt the AC supply in the event of a fault. This is not required if the optional internal braking resistor is used

\* Required for size 9E, 10E and 11E.

## 6.3 Quick start commissioning / start-up









### 6.3.1 Open loop

Action	Detail	
Before power-up	Ensure: <ul style="list-style-type: none"> <li>The drive enable signal is not given (terminal 31)</li> <li>Run signal is not given</li> <li>Motor is connected</li> </ul>	
Power-up the drive	Verify that Open Loop mode is displayed as the drive powers up. If the mode is incorrect see section 5.6 <i>Changing the operating mode</i> on page 35. Ensure: <ul style="list-style-type: none"> <li>Drive displays 'Inhibit'</li> </ul> If the drive trips, see Chapter 11 <i>Diagnostics</i> on page 183.	
Enter motor nameplate details	Enter: <ul style="list-style-type: none"> <li>Motor rated frequency in Pr <b>00.047</b> (Hz)</li> <li>Motor rated current in Pr <b>00.046</b> (A)</li> <li>Motor rated speed in Pr <b>00.045</b> (rpm)</li> <li>Motor rated voltage in Pr <b>00.044</b> (V) - check if <math>\Delta</math> or <math>\Delta</math> connection</li> </ul>	
Set maximum frequency	Enter: <ul style="list-style-type: none"> <li>Maximum frequency in Pr <b>00.002</b> (Hz)</li> </ul>	
Set acceleration / deceleration rates	Enter: <ul style="list-style-type: none"> <li>Acceleration rate in Pr <b>00.003</b> (s/100 Hz)</li> <li>Deceleration rate in Pr <b>00.004</b> (s/100 Hz) (If braking resistor installed, set Pr <b>00.015</b> = Fast. Also ensure Pr <b>10.030</b> and Pr <b>10.031</b> and Pr <b>10.061</b> are set correctly, otherwise premature 'Brake R Too Hot' trips may be seen).</li> </ul>	
Motor thermistor set-up	The motor thermistor can be selected in Pr <b>00.021</b> ( <b>07.015</b> ). Refer to Pr <b>00.021</b> ( <b>07.015</b> ) for further information.	
Autotune	<p>The drive is able to perform either a stationary or a rotating autotune. The motor must be at a standstill before an autotune is enabled. A rotating autotune should be used whenever possible so the measured value of power factor of the motor is used by the drive.</p> <div style="border: 1px solid black; padding: 5px; margin-bottom: 10px;"> <p><b>WARNING</b> A rotating autotune will cause the motor to accelerate up to <math>2/3</math> base speed in the direction selected regardless of the reference provided. Once complete the motor will coast to a stop. The enable signal must be removed before the drive can be made to run at the required reference. The drive can be stopped at any time by removing the run signal or removing the drive enable.</p> </div> <ul style="list-style-type: none"> <li>A stationary autotune can be used when the motor is loaded and it is not possible to uncouple the load from the motor shaft. A stationary autotune measures stator resistance and transient inductance of the motor and values relating to deadtime compensation from the drive. These are required for good performance in vector control modes. A stationary autotune does not measure the power factor of the motor so the value on the motor nameplate must be entered into Pr <b>00.043</b>.</li> <li>A rotating autotune should only be used if the motor is uncoupled. A rotating autotune first performs a stationary autotune before rotating the motor at <math>2/3</math> base speed in the direction selected. The rotating autotune measures the power factor of the motor.</li> </ul> <p>To perform an autotune:</p> <ul style="list-style-type: none"> <li>Set Pr <b>00.040</b> = 1 for a stationary autotune or set Pr <b>00.040</b> = 2 for a rotating autotune</li> <li>Close the Drive Enable signal (terminal 31). The drive will display 'Ready'.</li> <li>Close the run signal (terminal 26 or 27). The upper row of the display will flash 'Auto Tune' while the drive is performing the autotune.</li> <li>Wait for the drive to display 'Ready' or 'Inhibit' and for the motor to come to a standstill.</li> </ul> <p>If the drive trips, see Chapter 11 <i>Diagnostics</i> on page 183.</p> <ul style="list-style-type: none"> <li>Remove the drive enable and run signal from the drive.</li> </ul>	
Save parameters	Select 'Save Parameters' in Pr <b>mm.000</b> (alternatively enter a value of 1001 in Pr <b>mm.000</b> ) and press the red  reset button or toggle the reset digital input.	
Run	Drive is now ready to run	

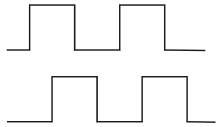
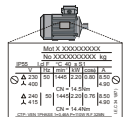
### 6.3.2 RFC - A mode (with position feedback)

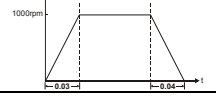
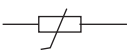
#### Induction motor with position feedback using optional SI-Encoder module

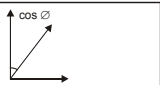
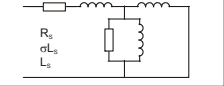
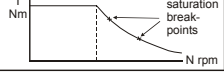
Only an incremental quadrature encoder as supported by the optional SI-Encoder module will be considered here.

Action	Detail	
Before power-up	Ensure: <ul style="list-style-type: none"> <li>The drive enable signal is not given (terminal 31).</li> <li>Run signal is not given</li> <li>Motor and feedback device are connected</li> </ul>	
Power-up the drive	Verify that RFC-A mode is displayed as the drive powers up. If the mode is incorrect see section 5.6 <i>Changing the operating mode</i> on page 35, otherwise restore parameter defaults (See section 5.8 <i>Restoring parameter defaults</i> on page 36). Ensure: <ul style="list-style-type: none"> <li>Drive displays 'Inhibit'</li> </ul> If the drive trips, see Chapter 11 <i>Diagnostics</i> on page 183.	
Enable motor feedback and set parameters	<b>Incremental encoder basic set-up</b> Set Pr <b>03.024</b> = Feedback (0) Enter: <ul style="list-style-type: none"> <li>Encoder power supply in Pr. <b>mm.036</b> = 5 V (0), 8 V (1) or 15 V (2). *</li> </ul> <b>NOTE</b> If output voltage from the encoder is >5 V, then the termination resistors must be disabled Pr <b>mm.039</b> to 0. *   Setting the encoder voltage supply too high for the encoder could result in damage to the feedback device. <b>CAUTION</b> <ul style="list-style-type: none"> <li>Drive encoder Lines Per Revolution (LPR) in Pr <b>mm.034</b> (set according to encoder) *</li> <li>Drive encoder termination resistor setting in Pr <b>mm.039</b>: * <ul style="list-style-type: none"> <li>0 = A-A\, B-B\ termination resistors disabled</li> <li>1 = A-A\, B-B\, termination resistors enabled</li> </ul> </li> </ul> * <b>mm</b> is dependant on the slot into which the SI-Encoder module is installed (15 = Slot 1, 16 = Slot 2, 17 = Slot 3).	
Enter motor nameplate details	<ul style="list-style-type: none"> <li>Motor rated frequency in Pr <b>00.047</b> (Hz)</li> <li>Motor rated current in Pr <b>00.046</b> (A)</li> <li>Motor rated speed in Pr <b>00.045</b> (rpm)</li> <li>Motor rated voltage in Pr <b>00.044</b> (V) - check if <math>\Delta</math> or <math>\Lambda</math> connection</li> </ul>	
Set maximum speed	Enter: Maximum speed in Pr <b>00.002</b> (rpm)	
Set acceleration / deceleration rates	Enter: <ul style="list-style-type: none"> <li>Acceleration rate in Pr <b>00.003</b> (s/1000 rpm)</li> <li>Deceleration rate in Pr <b>00.004</b> (s/1000 rpm) (If braking resistor installed, set Pr <b>00.015</b> = Fast. Also ensure Pr <b>10.030</b>, Pr <b>10.031</b> and Pr <b>10.061</b> are set correctly, otherwise premature 'Brake R Too Hot' trips may be seen).</li> </ul>	
Motor thermistor set-up	The motor thermistor can be selected in Pr <b>00.021</b> { <b>07.015</b> } Refer to Pr <b>00.021</b> { <b>07.015</b> } for further information.	
Autotune	The drive is able to perform either a stationary or a rotating autotune. The motor must be at a standstill before an autotune is enabled. A stationary autotune will give moderate performance whereas a rotating autotune will give improved performance as it measures the actual values of the motor parameters required by the drive.   A rotating autotune will cause the motor to accelerate up to $\frac{2}{3}$ base speed in the direction selected regardless of the reference provided. Once complete the motor will coast to a stop. The enable signal must be removed before the drive can be made to run at the required reference. <b>WARNING</b> The drive can be stopped at any time by removing the run signal or removing the drive enable. <ul style="list-style-type: none"> <li>A stationary autotune can be used when the motor is loaded and it is not possible to uncouple the load from the motor shaft. The stationary autotune measures the stator resistance and transient inductance of the motor and values relating to deadtime compensation from the drive. Measured values are used to calculate the current loop gains, and at the end of the test the values in Pr <b>00.038</b> and Pr <b>00.039</b> are updated. A stationary autotune does not measure the power factor of the motor so the value on the motor nameplate must be entered into Pr <b>00.043</b>.</li> <li>A rotating autotune should only be used if the motor is uncoupled. A rotating autotune first performs a stationary autotune before rotating the motor at <math>\frac{2}{3}</math> base speed in the direction selected. The rotating autotune measures the stator inductance of the motor and calculates the power factor.</li> </ul> To perform an autotune: <ul style="list-style-type: none"> <li>Set Pr <b>00.040</b> = 1 for a stationary autotune or set Pr <b>00.040</b> = 2 for a rotating autotune</li> <li>Close the drive enable signal (terminal 31). The drive will display 'Ready'.</li> <li>Close the run signal (terminal 26 or 27). The upper row of the display will flash 'Auto Tune' while the drive is performing the autotune.</li> <li>Wait for the drive to display 'Ready' or 'Inhibit' and for the motor to come to a standstill</li> </ul> If the drive trips, see Chapter 11 <i>Diagnostics</i> on page 183. <ul style="list-style-type: none"> <li>Remove the drive enable and run signal from the drive.</li> </ul>	  
Save parameters	Select 'Save Parameters' in Pr <b>mm.000</b> (alternatively enter a value of 1001 in Pr <b>mm.000</b> ) and press red 	
Run	Drive is now ready to run	

### 6.3.3 RFC - A Sensorless

#### Induction motor without position feedback





Action	Detail	
Before power-up	Ensure: <ul style="list-style-type: none"> <li>The drive enable signal is not given (terminal 31)</li> <li>Run signal is not given</li> <li>Motor is connected</li> </ul>	
Power-up the drive	Verify that RFC-A mode is displayed as the drive powers up. If the mode is incorrect see section 5.6 <i>Changing the operating mode</i> on page 35, otherwise restore parameter defaults (See section 5.8 <i>Restoring parameter defaults</i> on page 36). Ensure: <ul style="list-style-type: none"> <li>Drive displays 'Inhibit'</li> </ul> If the drive trips, see Chapter 11 <i>Diagnostics</i> on page 183.	
Enter motor nameplate details	Enter: <ul style="list-style-type: none"> <li>Motor rated frequency in Pr <b>00.047</b> (Hz)</li> <li>Motor rated current in Pr <b>00.046</b> (A)</li> <li>Motor rated speed in Pr <b>00.045</b> (rpm)</li> <li>Motor rated voltage in Pr <b>00.044</b> (V) - check if <math>\Delta</math> or <math>\Delta</math> connection</li> </ul>	
Set maximum speed	Enter: <ul style="list-style-type: none"> <li>Maximum speed in Pr <b>00.002</b> (rpm)</li> </ul>	
Set acceleration / deceleration rates	Enter: <ul style="list-style-type: none"> <li>Acceleration rate in Pr <b>00.003</b> (s/1000rpm)</li> <li>Deceleration rate in Pr <b>00.004</b> (s/1000rpm) (If braking resistor installed, set Pr <b>00.015</b> = FAST. Also ensure Pr <b>10.030</b>, Pr <b>10.031</b> and Pr <b>10.061</b> are set correctly, otherwise premature 'Brake R Too Hot' trips may be seen).</li> </ul>	
Autotune	<p>The drive is able to perform either a stationary or a rotating autotune. The motor must be at a standstill before an autotune is enabled. A stationary autotune will give moderate performance whereas a rotating autotune will give improved performance as it measures the actual values of the motor parameters required by the drive.</p> <p><b>NOTE</b> It is highly recommended that a rotating autotune is performed (Pr <b>00.040</b> set to 2).</p> <div style="border: 1px solid black; padding: 5px; margin: 10px 0;"> <p><b>WARNING</b> A rotating autotune will cause the motor to accelerate up to <math>2/3</math> base speed in the direction selected regardless of the reference provided. Once complete the motor will coast to a stop. The enable signal must be removed before the drive can be made to run at the required reference. The drive can be stopped at any time by removing the run signal or removing the drive enable.</p> </div> <ul style="list-style-type: none"> <li>A stationary autotune can be used when the motor is loaded and it is not possible to uncouple the load from the motor shaft. The stationary autotune measures the stator resistance and transient inductance of the motor and values relating to deadtime compensation from the drive. Measured values are used to calculate the current loop gains, and at the end of the test the values in Pr <b>00.038</b> and Pr <b>00.039</b> are updated. A stationary autotune does not measure the power factor of the motor so the value on the motor nameplate must be entered into Pr <b>00.043</b>.</li> <li>A rotating autotune should only be used if the motor is uncoupled. A rotating autotune first performs a stationary autotune before rotating the motor at <math>2/3</math> base speed in the direction selected. The rotating autotune measures the stator inductance of the motor and calculates the power factor.</li> </ul> <p>To perform an autotune:</p> <ul style="list-style-type: none"> <li>Set Pr <b>00.040</b> = 1 for a stationary autotune or set Pr <b>00.040</b> = 2 for a rotating autotune</li> <li>Close the drive enable signal (terminal 31). The drive will display 'Ready' or 'Inhibit'.</li> <li>Close the run signal (terminal 26 or 27). The lower display will flash 'Autotune' while the drive is performing the autotune.</li> <li>Wait for the drive to display 'Ready' or 'Inhibit' and for the motor to come to a standstill.</li> </ul> <p>If the drive trips, see Chapter 11 <i>Diagnostics</i> on page 183.</p> <ul style="list-style-type: none"> <li>Remove the drive enable and run signal from the drive.</li> </ul>	  
Save parameters	Select 'Save Parameters' in Pr <b>mm.000</b> (alternatively enter a value of 1001 in Pr <b>mm.000</b> ) and press red	
Run	Drive is now ready to run	

### 6.3.4 RFC-S Sensorless

#### Permanent magnet motor without position feedback (non Dyneo LSRPM motor)

Action	Detail	
Before power-up	<p>Ensure:</p> <ul style="list-style-type: none"> <li>The drive enable signal is not given (terminal 31).</li> <li>Run signal is not given</li> <li>Motor is connected</li> </ul>	
Power-up the drive	<p>Verify that RFC-S mode is displayed as the drive powers up. If the mode is incorrect see Chapter 5.6 <i>Changing the operating mode</i> on page 35, otherwise restore parameter defaults (see Chapter 5.8 <i>Restoring parameter defaults</i> on page 36).</p> <p>Ensure:</p> <ul style="list-style-type: none"> <li>Drive displays 'inhibit'</li> </ul> <p>If the drive trips, see Chapter 11 <i>Diagnostics</i> on page 183.</p>	
Enter motor nameplate details	<p>Enter:</p> <ul style="list-style-type: none"> <li>Set Pr <b>29.200</b> = 0 (if parameter is present) to disable LSRPM motor quick setup system</li> <li>Motor rated current in Pr <b>00.046</b> (A)</li> </ul> <p>Ensure that this equal to or less than the Heavy Duty rating of the drive otherwise 'Motor Too Hot' trips may occur during the autotune.</p> <ul style="list-style-type: none"> <li>Number of poles in Pr <b>00.042</b></li> <li>Motor rated voltage in Pr <b>00.044</b> (V)</li> </ul>	
Set maximum speed	<p>Enter:</p> <ul style="list-style-type: none"> <li>Maximum speed in Pr <b>00.002</b> (rpm)</li> </ul>	
Set acceleration / deceleration rates	<p>Enter:</p> <ul style="list-style-type: none"> <li>Acceleration rate in Pr <b>00.003</b> (s/1000 rpm)</li> <li>Deceleration rate in Pr <b>00.004</b> (s/1000 rpm) (If braking resistor installed, set Pr <b>00.015</b> = Fast. Also ensure Pr <b>10.030</b>, Pr <b>10.031</b> and Pr <b>10.061</b> are set correctly, otherwise premature 'Brake R Too Hot' trips may be seen).</li> </ul>	
Autotune	<p>The drive is able to perform a stationary autotune. The motor must be at a standstill before an autotune is enabled. A stationary autotune will give moderate performance.</p> <ul style="list-style-type: none"> <li>A stationary autotune is performed to locate the flux axis of the motor. The stationary autotune measures the stator resistance, inductance in flux axis, inductance in torque axis with no load on the motor and values relating to deadtime compensation from the drive. Measured values are used to calculate the current loop gains, and at the end of the test the values in Pr <b>00.038</b> and Pr <b>00.039</b> are updated.</li> </ul> <p>To perform an autotune:</p> <ul style="list-style-type: none"> <li>Set Pr <b>00.040</b> = 1 or 2 for a stationary autotune. (Both perform the same tests).</li> <li>Close the run signal (terminal 26 or 27).</li> <li>Close the drive enable signal (terminal 31). The upper row of the display will flash 'Auto Tune' while the drive is performing the test.</li> <li>Wait for the drive to display 'Ready' or 'Inhibit'.</li> </ul> <p>If the drive trips it cannot be reset until the drive enable signal (terminal 31) has been removed. See Chapter 11 <i>Diagnostics</i> on page 183.</p> <ul style="list-style-type: none"> <li>Remove the drive enabled and run signal from the drive.</li> </ul>	
Check Saliency	<p>In sensorless mode, when the motor speed is below Pr <b>00.045</b> / 10, a special low speed algorithm must be used to control the motor. There are two modes available, with the mode chosen based on the saliency of the motor.</p> <p>The ratio No-load L<sub>q</sub> (Pr <b>00.056</b>) / L<sub>d</sub> (Pr <b>05.024</b>) provides a measure of the saliency. If this value is &gt; 1.1, then Injection (0) mode may be used (this is default). Current (2) mode may be used (but with limitations). If this value is &lt; 1.1, then Current (2) mode must be used. Non-salient (1) mode is provided for LSRPM motors (this is the default).</p>	
Save parameters	<p>Select 'Save Parameters' in Pr <b>mm.000</b> (alternatively enter a value of 1001 in Pr <b>mm.000</b>) and press red  reset button or toggle the reset digital input.</p>	
Run	<p>Drive is now ready to run</p>	

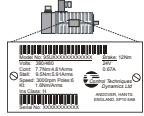
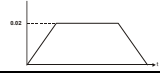
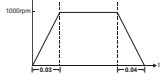
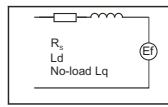
### 6.3.5 RFC-S mode (Sensorless) Dyneo LSRPM motor set-up with V01.12.02.00 onwards firmware

Action	Detail	
Before power-up	Ensure: <ul style="list-style-type: none"> <li>The drive enable signal is not given (terminal 31).</li> <li>Run signal is not given</li> <li>Motor is connected</li> </ul>	
Power-up the drive	Verify that RFC-S mode is displayed as the drive powers up. If the mode is incorrect see section 5.6 <i>Changing the operating mode</i> on page 35, otherwise restore parameter defaults (see section 5.8 <i>Restoring parameter defaults</i> on page 36). Ensure that the drive displays 'inhibit'	
Enter motor nameplate details	Enter: <ul style="list-style-type: none"> <li>Motor rated current in Pr <b>00.046</b> (A)*</li> <li>Rated speed in Pr <b>00.045</b> (rpm)</li> <li>Volts per 1000 rpm in Pr <b>00.047</b> (V / 1000 rpm)</li> </ul> Motor rated voltage Pr <b>00.044</b> and number of motor poles Pr <b>00.042</b> are also required but the default values in RFC-S mode for the Unidrive M600 are set to match those required by the Dyneo LSRPM motor.  From firmware version 01.12.xx.xx onwards, the rated current from the motor nameplate is entered into Pr <b>00.046</b> ( <b>05.007</b> ) and will be updated automatically to the sensorless value after an autotune.	
Enter motor thermal data and switching frequency	Enter: <ul style="list-style-type: none"> <li>Motor Thermal Time Constant value into Pr <b>00.053</b> (s) from the values specified in Table 6-3 to Table 6-9 .</li> <li>Switching frequency value into Pr <b>00.041</b> (kHz) from the values specified in Table 6-3 to Table 6-9 .</li> </ul>	
Set maximum speed	Enter: <ul style="list-style-type: none"> <li>Maximum speed in Pr <b>00.002</b> (rpm)</li> </ul>	
Set acceleration / deceleration rates	Enter: <ul style="list-style-type: none"> <li>Acceleration rate in Pr <b>00.003</b> (s to Pr <b>00.002</b>)</li> <li>Deceleration rate in Pr <b>00.004</b></li> </ul>	
Autotune	Perform a stationary autotune. The motor must be at a standstill before an autotune is enabled. To perform an autotune: <ul style="list-style-type: none"> <li>Set Pr <b>00.040</b> = 1 or 2 for a stationary autotune. (Both perform the same tests).</li> <li>Close the drive enable signal (terminal 31). The drive will display 'Ready' or 'Inhibit'.</li> <li>Close the run signal (terminal 26 or 27).</li> <li>The upper row of the display will flash 'Auto Tune' during the test.</li> <li>Wait for the drive to display 'Inhibit' or 'Ready'.</li> </ul> If the drive trips it cannot be reset until the drive enable signal (terminal 31) has been removed. <ul style="list-style-type: none"> <li>Remove the drive enable from the drive.</li> </ul> If no trip occurs during or after the autotune then this indicates that the drive has been correctly set-up and is ready to run the Dyneo LSRPM motor. If a User Trip 40 occurs, then this indicates that the motor rated current or motor rated speed was not recognized as being a valid value for a Dyneo LSRPM motor. Check the <i>Rated Speed</i> (Pr <b>00.045</b> ) and <i>Rated Current</i> (Pr <b>00.046</b> ) entered in the drive against the Dyneo LSRPM motors listed in Table 6-3 to Table 6-9 . Correct the values and perform an autotune again.	
Check Saliency	In sensorless mode, when the motor speed is below Pr <b>00.045</b> / 10, a special low speed algorithm must be used to control the motor. There are two modes available, with the mode chosen based on the saliency of the motor. The Dyneo LSRPM motors have little or no saliency so require the non-salient low speed mode to be used. Set Pr <b>00.054</b> to: Non-salient (1). Non-salient mode requires the ramp rate to be no slower than 5 s / 1000 rpm when operating in the region below <i>Rated Speed</i> Pr <b>00.045</b> / 10. The drive contains a feature to ensure that the ramp rate during the low speed region is at least 4 s / 1000 rpm. This feature is enabled automatically after a successful set-up of the Dyneo LSRPM motor.	
Save parameters	Select 'Save Parameters' in Pr <b>mm.000</b> (alternatively enter a value of 1001 in Pr <b>mm.000</b> ) and press red  reset button or toggle the reset digital input.	
Run	Drive is now ready to run	

\*When using V01.11.01.00 firmware the Sensorless motor rated current must be used rather than the nameplate value (see Table 6-3 to Table 6-9 ).

**Table 6-3 Dyneo LSRPM 1500 rpm motors**

LSRPM Motor model	Motor rated current (nameplate value) Pr 00.046*	Sensorless motor rated current after autotune*	Switching frequency Pr 00.041	Ke Pr 00.047	Motor Thermal Time Constant Pr 00.053
	A	A	kHz	V/1000 rpm	s
1500 LSRPM 90SL 3 kW	5.9	6.0	3	212	850
1500 LSRPM 100L 4.5 kW	8.6	8.6	3	223	850
1500 LSRPM 100L 6 kW	10.9	10.9	3	237	850
1500 LSRPM 132M 8.2 kW	16.0	17.3	3	232	1050
1500 LSRPM 132M 10.2 kW	19.9	20.6	3	234	1050
1500 LSRPM 132M 12 kW	23.0	23.6	3	237	1050
1500 LSRPM 160MP 15.6 kW	30.0	30.0	3	241	1050
1500 LSRPM 160MP 19.2 kW	37.0	37.0	3	242	1050
1500 LSRPM 160LR 22.8 kW	43.0	43.0	3	245	1050
1500 LSRPM 200L 25 kW	56.0	60.8	3	204	900
1500 LSRPM 200L 33 kW	65.5	69.0	3	218	900
1500 LSRPM 200L / 225ST1 40 kW	82.9	82.9	3	215	900
1500 LSRPM 200LU / 250MY 55 kW	110	110	3	221	900
1500 LSRPM 225MR1 70 kW	142	142	3	218	900
1500 LSRPM 250ME / 280SCM 85 kW	175	175	3	208	1150
1500 LSRPM 280SC 105 kW	215	215	3	210	1150
1500 LSRPM 280SD / 315SN 125 kW	245	245	3	228	1150
1500 LSRPM 280MK1 / 315MP1 145 kW	265	273	3	219	2600
1500 LSRPM 315SP1 175 kW	350	350	3	213	2600
1500 LSRPM 315MR1 220 kW	415	415	3	226	2600
1500 LSRPM 315MR1 250 kW	490	490	3	226	2600

\* From firmware version 01.12.xx.xx onwards, the rated current from the motor nameplate is entered into Pr **00.046 {05.007}** and will be updated automatically to the sensorless value after an autotune.

**Table 6-4 Dyneo LSRPM 1800 rpm motors**

LSRPM Motor model	Motor rated current (nameplate value) Pr 00.046*	Sensorless motor rated current after autotune*	Switching frequency Pr 00.041	Ke Pr 00.047	Motor Thermal Time Constant Pr 00.053
	A	A	kHz	V/1000 rpm	s
1800 LSRPM 132M 9.8 kW	19.0	19.8	3	188	1050
1800 LSRPM 132M 12.3 kW	24.0	24.7	3	197	1050
1800 LSRPM 132M 14.4 kW	28.0	28.0	3	191	1050
1800 LSRPM 160MP 18.7 kW	36.0	36.0	3	206	1050
1800 LSRPM 160MP 23 kW	42.9	42.9	3	204	1050
1800 LSRPM 160LR 27.3 kW	52.0	52.0	3	205	1050
1800 LSRPM 200L 33 kW	79.0	80.3	3	170	900
1800 LSRPM 200L 40 kW	82.5	85.0	3	172	900
1800 LSRPM 200L 55 kW	120	124	3	181	900
1800 LSRPM 225ST1 70 kW	145	145	3	182	900
1800 LSRPM 225MR1 85 kW	172	172	3	187	900
1800 LSRPM 250ME 100 kW	204	207	3	195	1150
1800 LSRPM 280SC 125 kW	248	248	3	183	1150
1800 LSRPM 280SD 150 kW	295	295	3	195	1150
1800 LSRPM 280MK1 175 kW	330	330	3	196	2600
1800 LSRPM 315SP1 195 kW	370	370	3	206	2600
1800 LSRPM 315MR1 230 kW	425	425	3	201	2600

\* From firmware version 01.12.xx.xx onwards, the rated current from the motor nameplate is entered into Pr **00.046 {05.007}** and will be updated automatically to the sensorless value after an autotune.

**Table 6-5 Dyneo LSRPM 2400 rpm motors**

LSRPM Motor model	Motor rated current (nameplate value) Pr 00.046*	Sensorless motor rated current after autotune*	Switching frequency Pr 00.041	Ke Pr 00.047	Motor Thermal Time Constant Pr 00.053
	A	A	kHz	V/1000 rpm	s
2400 LSRPM 90SL 4.8 kW	9.1	9.4	4	145	850
2400 LSRPM 100L 7.2 kW	13.4	13.4	4	146	850
2400 LSRPM 100L 9.5 kW	17.7	17.7	4	151	850
2400 LSRPM 132M 13.1 kW	25.0	27.2	8	149	1050
2400 LSRPM 132M 16.3 kW	31.0	32.1	8	140	1050
2400 LSRPM 132M 19.2 kW	37.0	37.1	8	152	1050
2400 LSRPM 160MP 25 kW	47.0	47.0	8	153	1050
2400 LSRPM 160MP 31 kW	58.0	58.0	8	156	1050
2400 LSRPM 160LR 36 kW	69.0	69.0	8	156	1050
2400 LSRPM 200L 50 kW	110	110	4	136	900
2400 LSRPM 200L1 65 kW	137	137	4	128	900
2400 LSRPM 200L1 80 kW	160	164	4	145	900
2400 LSRPM 225MR1 100 kW	200	201	4	142	900
2400 LSRPM 250SE 125 kW	235	240	4	146	1150
2400 LSRPM 250ME 150 kW	285	288	4	146	1150
2400 LSRPM 280SD1 190 kW	350	361	4	152	1150
2400 LSRPM 280MK1 230 kW	429	429	4	147	2600

\* From firmware version 01.12.xx.xx onwards, the rated current from the motor nameplate is entered into Pr 00.046 {05.007} and will be updated automatically to the sensorless value after an autotune.

**Table 6-6 Dyneo LSRPM 3000 rpm motors**

LSRPM Motor model	Motor rated current (nameplate value) Pr 00.046*	Sensorless motor rated current after autotune*	Switching frequency Pr 00.041	Ke Pr 00.047	Motor Thermal Time Constant Pr 00.053
	A	A	kHz	V/1000 rpm	s
3000 LSRPM 90SL 5.8 kW	11.0	11.1	4	120	850
3000 LSRPM 100L 8.7 kW	16.2	16.2	4	131	850
3000 LSRPM 100L 11.6 kW	21.0	21.0	4	134	850
3000 LSRPM 132M 15.8 kW	30.0	31.8	8	121	1050
3000 LSRPM 132M 19.7 kW	38.0	38.0	8	121	1050
3000 LSRPM 132M 23 kW	44.0	44.0	8	126	1050
3000 LSRPM 160MP 30 kW	57.0	57.0	8	127	1050
3000 LSRPM 160MP 37 kW	67.8	67.8	8	128	1050
3000 LSRPM 160LR 44 kW	82.0	82.0	8	129	1050
3000 LSRPM 200L 50 kW	111	116	4	109	900
3000 LSRPM 200L1 65 kW	126	136	4	118	900
3000 LSRPM 200L1 85 kW	170	170	4	125	900
3000 LSRPM 225ST2 110 kW	215	219	4	118	900
3000 LSRPM 250SE 145 kW	285	285	4	114	1150
3000 LSRPM 250ME1 170 kW	338	344	4	111	1150
3000 LSRPM 280SD1 200 kW	365	365	4	126	1150
3000 LSRPM 280SD1 220 kW	370	398	4	130	1150

\* From firmware version 01.12.xx.xx onwards, the rated current from the motor nameplate is entered into Pr 00.046 {05.007} and will be updated automatically to the sensorless value after an autotune.

**Table 6-7 Dyneo LSRPM 3600 rpm motors**

LSRPM Motor model	Motor rated current (nameplate value) Pr 00.046*	Sensorless motor rated current after autotune*	Switching frequency Pr 00.041	Ke Pr 00.047	Motor Thermal Time Constant Pr 00.053
	A	A	kHz	V/1000 rpm	s
3600 LSRPM 132M 17.6 kW	33.0	33.7	8	103	1050
3600 LSRPM 132M 22 kW	39.4	41.2	8	103	1050
3600 LSRPM 132M 26 kW	48.0	48.0	8	106	1050
3600 LSRPM 160MP 34 kW	63.0	63.0	8	106	1050
3600 LSRPM 160MP 41 kW	77.0	77.0	8	107	1050
3600 LSRPM 160LR 49 kW	91.0	91.0	8	110	1050
3600 LSRPM 200L1 70 kW	129	137	4	100	900
3600 LSRPM 200L1 85 kW	162	162	4	100	900
3600 LSRPM 200LU2 115 kW	217	232	4	103	900
3600 LSRPM 225SG 132 kW	250	250	4	103	1150
3600 LSRPM 250SE1 165 kW	330	330	4	96	1150
3600 LSRPM 250SE1 190 kW	350	360	4	106	1150
3600 LSRPM 280SD1 240 kW	420	429	4	108	1150

\* From firmware version 01.12.xx.xx onwards, the rated current from the motor nameplate is entered into Pr 00.046 {05.007} and will be updated automatically to the sensorless value after an autotune.

**Table 6-8 Dyneo LSRPM 4500 rpm motors**

LSRPM Motor model	Motor rated current (nameplate value) Pr 00.046*	Sensorless motor rated current after autotune*	Switching frequency Pr 00.041	Ke Pr 00.047	Motor Thermal Time Constant Pr 00.053
	A	A	kHz	V/1000 rpm	s
4500 LSRPM 132M 18.6 kW	35.0	35.0	8	86	1050
4500 LSRPM 132M 23 kW	44.0	44.0	8	84	1050
4500 LSRPM 132M 27 kW	51.0	51.0	8	83	1050
4500 LSRPM 160MP 35 kW	67.0	67.0	8	90	1050
4500 LSRPM 160MP 44 kW	81.0	81.0	8	92	1050
4500 LSRPM 160LR 52 kW	97.0	97.0	8	86	1050
4500 LSRPM 200L1 65 kW	130	142	8	82	900
4500 LSRPM 200L1 80 kW	160	172	8	82	900
4500 LSRPM 200L1 100 kW	200	200	8	79	900
4500 LSRPM 200L2 120 kW	230	230	8	82	900
4500 LSRPM 200LU2 135 kW	258	260	8	84	900
4500 LSRPM 225SR2 150 kW	262	281	8	91	900

\* From firmware version 01.12.xx.xx onwards, the rated current from the motor nameplate is entered into Pr 00.046 {05.007} and will be updated automatically to the sensorless value after an autotune.

**Table 6-9 Dyneo LSRPM 5500 rpm motors**

LSRPM Motor model	Motor rated current (nameplate value) Pr 00.046*	Sensorless motor rated current after autotune*	Switching frequency Pr 00.041	Ke Pr 00.047	Motor Thermal Time Constant Pr 00.053
	A	A	kHz	V/1000 rpm	s
5500 LSRPM 132M 18.6 kW	35.0	35.0	8	74	1050
5500 LSRPM 132M 23 kW	44.0	44.0	8	74	1050
5500 LSRPM 132M 27 kW	52.0	52.0	8	77	1050
5500 LSRPM 160MP 35 kW	67.0	67.0	8	76	1050
5500 LSRPM 160MP 44 kW	82.0	82.0	8	77	1050
5500 LSRPM 160LR 52 kW	97.0	97.0	8	77	1050
5500 LSRPM 200L1 70 kW	140	141	8	68	900
5500 LSRPM 200L1 85 kW	170	170	8	64	900
5500 LSRPM 200L1 100 kW	210	210	8	64	900
5500 LSRPM 200L2 140 kW	265	296	8	67	900

\* From firmware version 01.12.xx.xx onwards, the rated current from the motor nameplate is entered into Pr 00.046 {05.007} and will be updated automatically to the sensorless value after an autotune.

## 6.4 Quick start commissioning / start-up using Unidrive M Connect (V02.00.00.00 onwards)

Unidrive M Connect is a Windows™ based software commissioning/start-up tool for Unidrive M. Unidrive M Connect can be used for commissioning / start-up and monitoring, drive parameters can be uploaded, downloaded and compared and simple or custom menu listings can be created. Drive menus can be displayed in standard list format or as live block diagrams. Unidrive M Connect is able to communicate with a single drive or a network. Unidrive M Connect can be downloaded from [www.controltechniques.com](http://www.controltechniques.com) (file size approximately 100 MB).

### Unidrive M Connect system requirements

- Windows 8, Windows 7 SP1, Windows Vista SP2, Windows XP SP3
- Minimum of 1280 x 1024 screen resolution with 256 colours
- Microsoft.Net Frameworks 4.0 (this is provided in the downloaded file)
- Note that you must have administrator rights to install Unidrive M Connect

Any previous copy of Unidrive M Connect should be uninstalled before proceeding with the installation (existing projects will not be lost). Included within Unidrive M Connect is the *Parameter Reference Guide* for Unidrive M600.

### 6.4.1 Power-up the drive

1. Start Unidrive M Connect, and on the 'Project Management' screen select 'Scan serial RTU network' or 'Scan all connected drives'.

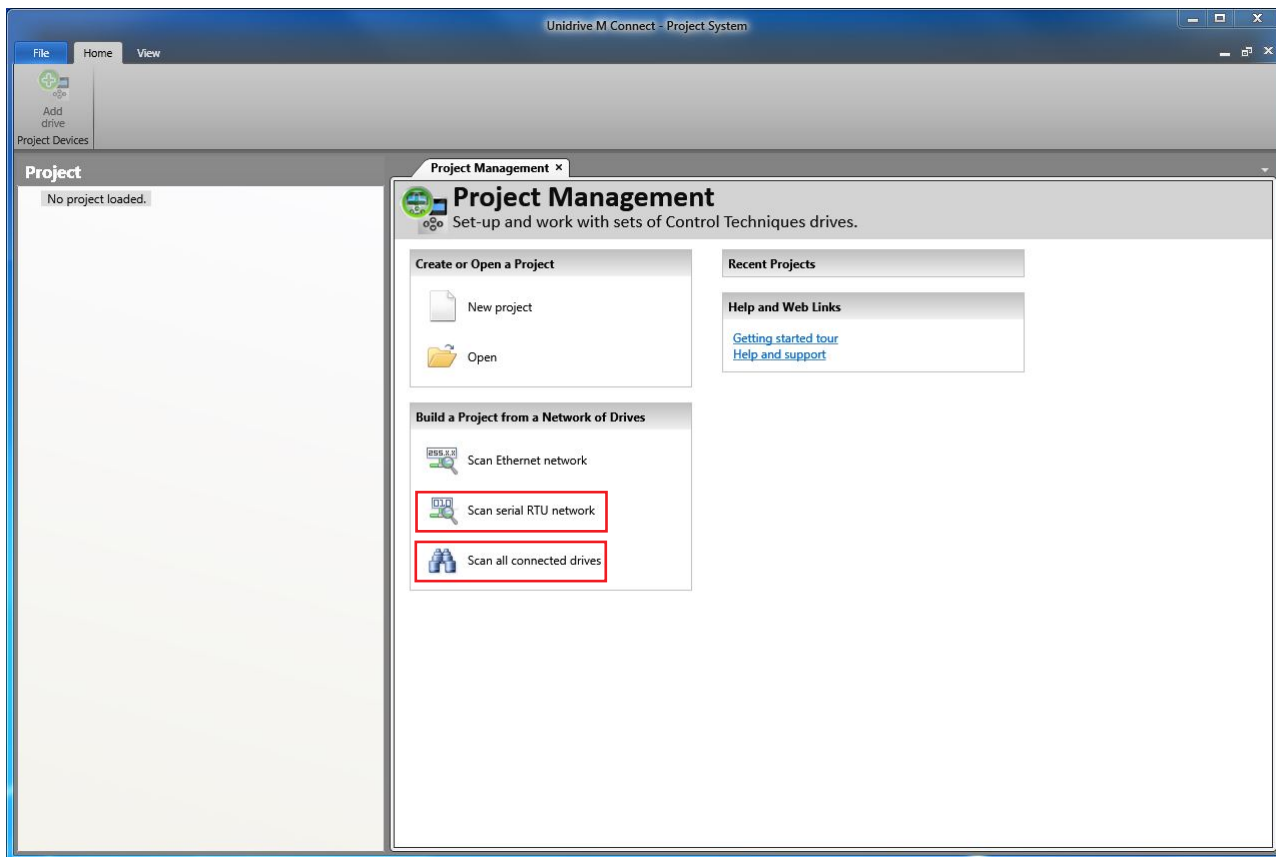

Select the discovered drive.

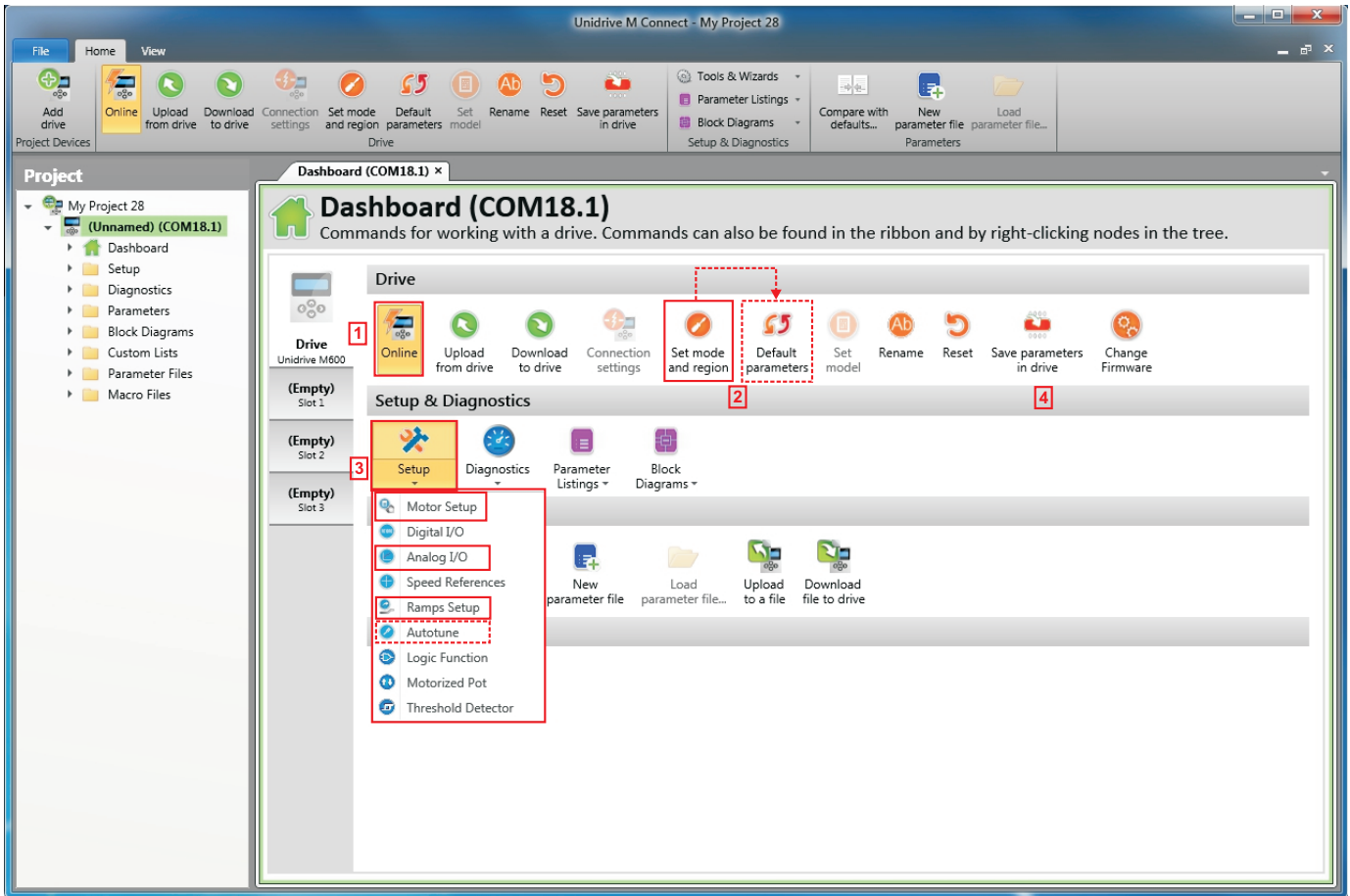

1. Select the 'Online' icon to connect with the drive. When a successful connection is made the icon will be highlighted orange.
2. Select 'Set mode and region'.  
If the required control mode is highlighted in the 'Drive Settings' dialog, then:
  - Change the supply frequency, if required and select 'Apply', otherwise select 'Cancel'.
  - Select 'Default parameters' from the Dashboard and in the 'Default Parameters' dialogue, select 'Apply'
 If the required control mode is not highlighted in the 'Drive Settings' dialog then:
  - Select the required mode and supply frequency.
  - Select 'Apply'.
3. Select 'Setup' and perform the steps highlighted (dotted lines indicate a step which may not need to be performed (see overleaf):

Action	Detail
Motor Setup	Unidrive M Connect contains a database for induction motors and permanent magnet motors. Provision is also made to enter motor nameplate data. The next section describes the use of the motor database for a Leroy Somer LSRPM motor used in RFC-S Sensorless mode.
Motor Feedback Setup	This only needs to be performed in RFC-A (with feedback) mode Set Pr <b>03.024</b> = Feedback (0) Enter: <ul style="list-style-type: none"> <li>Encoder power supply in Pr. <b>mm.036</b> = 5 V (0), 8 V (1) or 15 V (2). *</li> </ul> <p><b>NOTE</b> If output voltage from the encoder is &gt;5 V, then the termination resistors must be disabled Pr <b>mm.039</b> to 0. *</p> <div style="border: 1px solid black; padding: 5px;">  <p>Setting the encoder voltage supply too high for the encoder could result in damage to the feedback device.</p> <p><b>CAUTION</b></p> </div> <ul style="list-style-type: none"> <li>Drive encoder Lines Per Revolution (LPR) in Pr <b>mm.034</b> (set according to encoder) *</li> <li>Drive encoder termination resistor setting in Pr <b>mm.039</b>: * <ul style="list-style-type: none"> <li>0 = A-A\, B-B\ termination resistors disabled</li> <li>1 = A-A\, B-B\, termination resistors enabled</li> </ul> </li> </ul> <p>* <b>mm</b> is dependant on the slot into which the SI-Encoder module is installed (15 =Slot 1, 16 = Slot 2, 17 = Slot 3).</p>
Analog I/O	The motor thermistor can be selected in Pr <b>00.021</b> { <b>07.015</b> }. Refer to the parameter help for Pr <b>00.021</b> { <b>07.015</b> } for further information.
Ramps Setup	Enter the required Acceleration rate and Deceleration rate Note: If a braking resistor is installed, set 'Ramp mode' to 'Fast'. Also ensure Pr <b>10.030</b> and Pr <b>10.031</b> and Pr <b>10.061</b> are set correctly, otherwise premature 'Brake R Too Hot' trips may be seen).
Autotune	Not required when using data from the motor database for a Leroy Somer LSRPM motor used in RFC-S Sensorless mode.

4. Select 'Save parameters in drive' to perform a parameter save.  
The drive is now ready to run.

### 6.4.2 Use of the motor database for a Leroy Somer LSRPM motor for use in RFC-S Sensorless mode.

Select 'Motor Setup' from the 'Dashboard'.

On the 'Motor Setup' screen, select 'Choose a motor'.

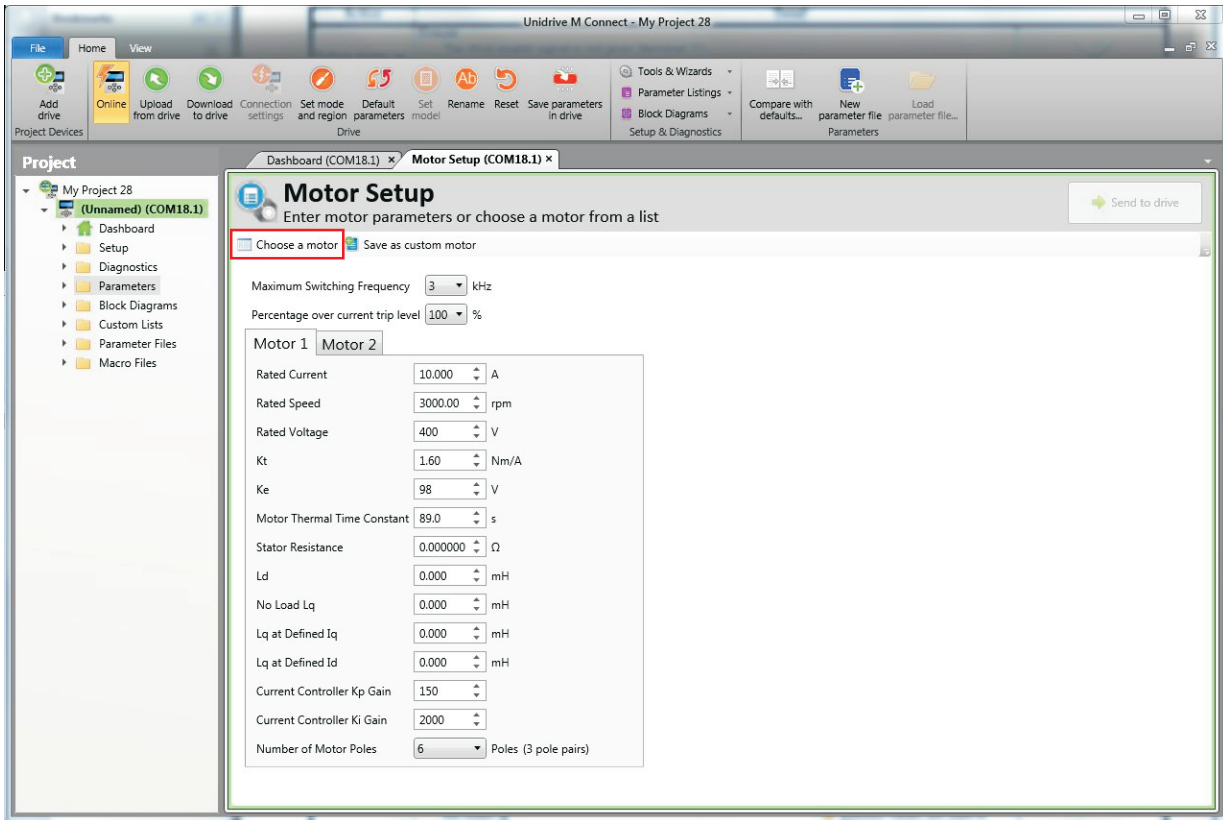

Select the required motor database:

Select the required motor from the list and click 'OK'.

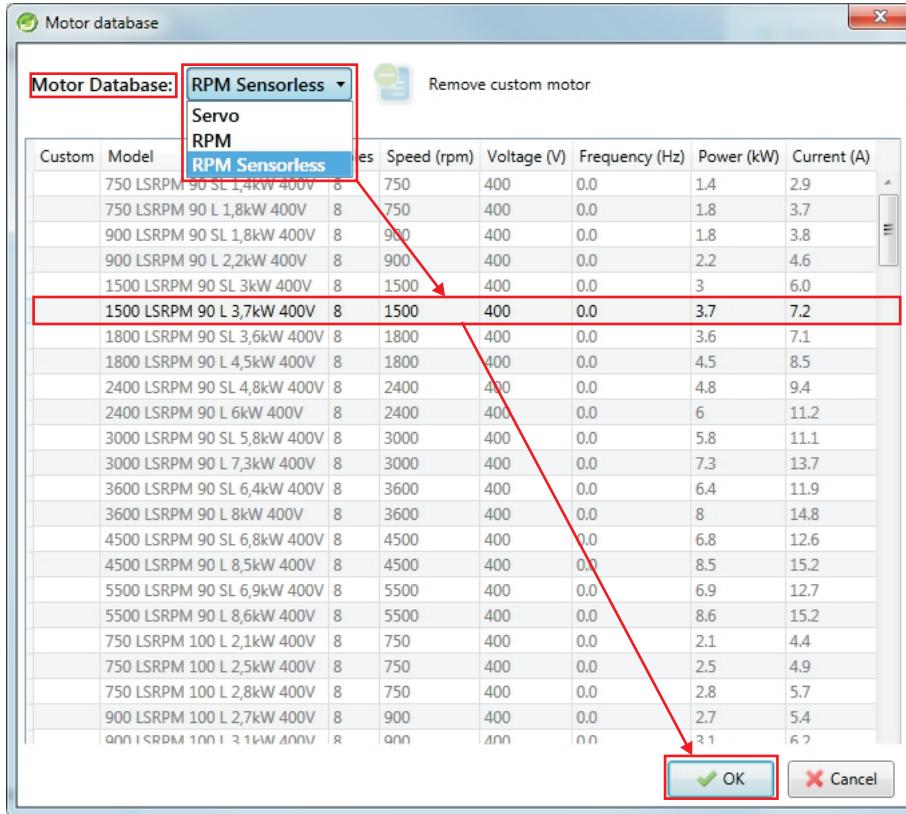

The data for the selected motor is displayed on the 'Motor Setup' screen. Click 'Send to drive' to set the associated parameters.

It is possible to set motor parameters for motor 2, by selecting the 'Motor 2' tab and following the same procedure.

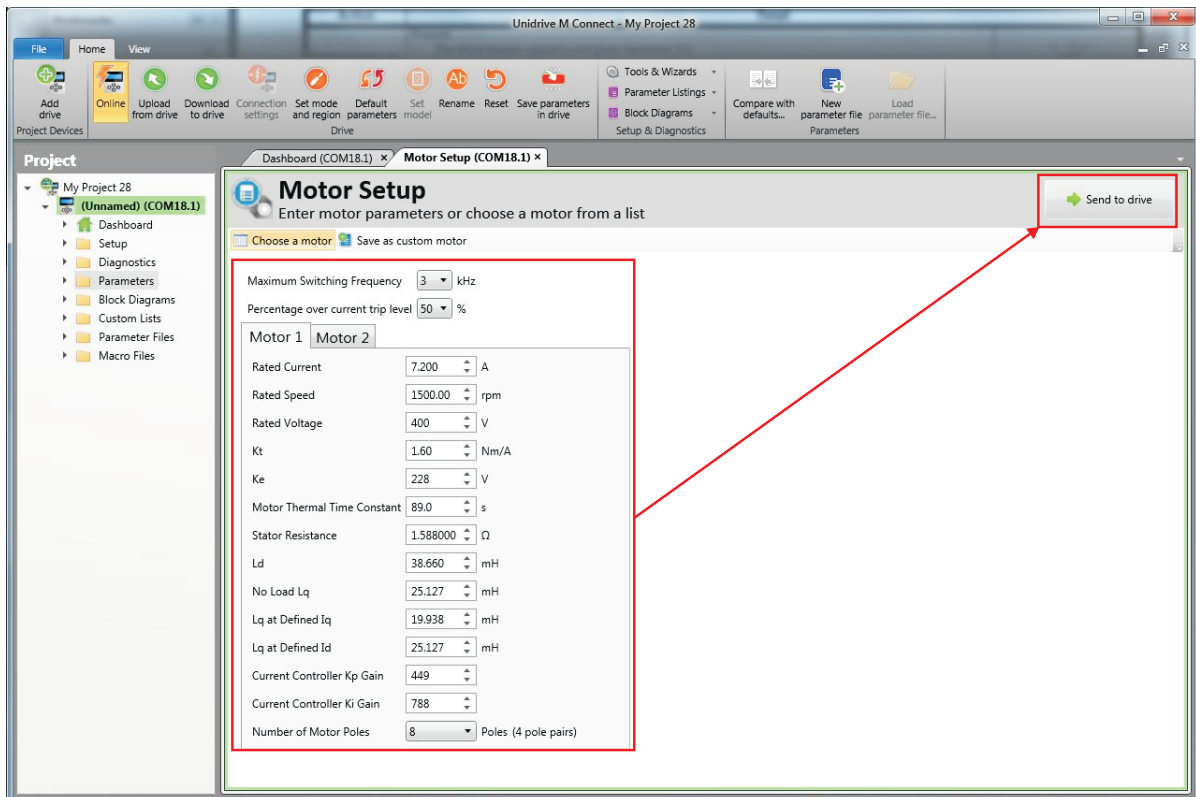

## 6.5 Diagnostics

If the drive trips, it is possible to interrogate the trip log from within Unidrive M Connect. Select 'Drive Trip Log' from the 'Dashboard'.

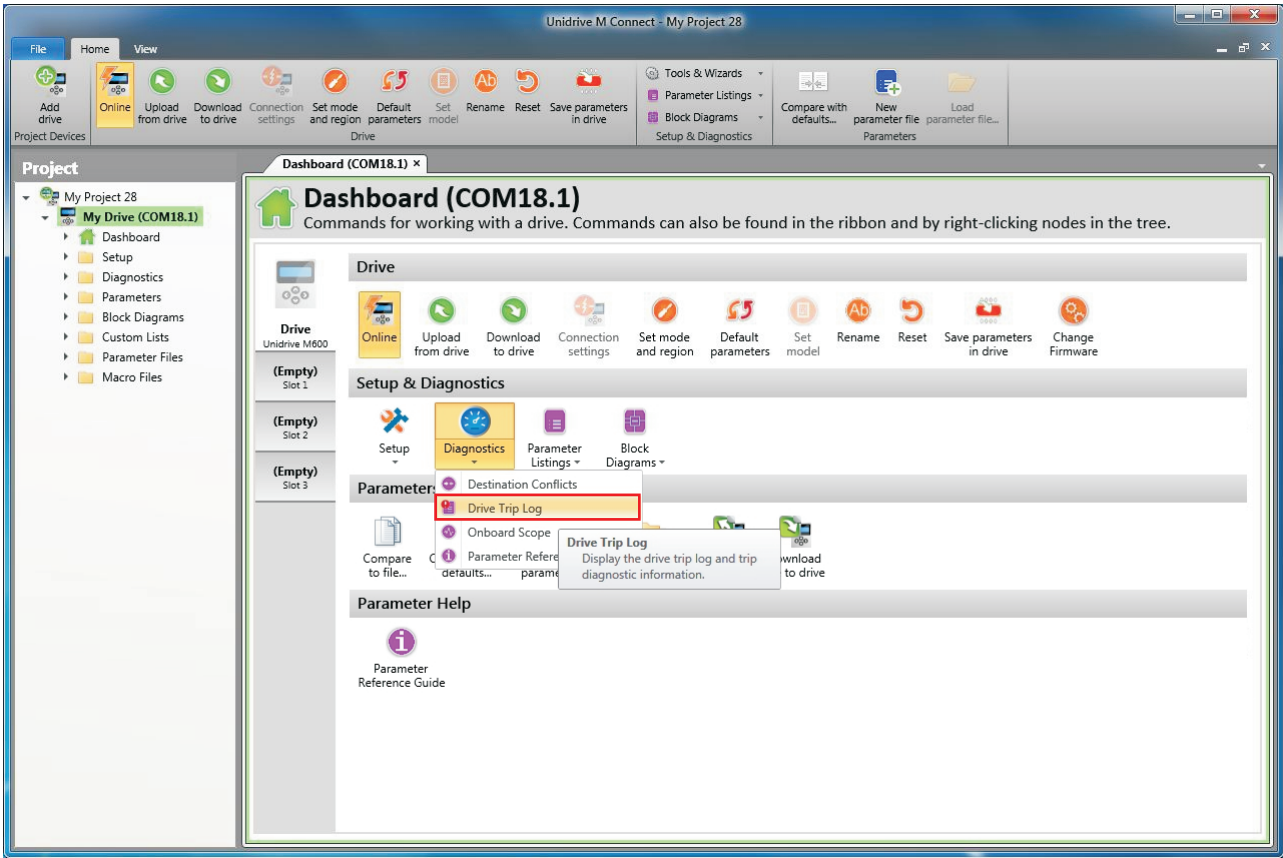

The drive trip log shows the trip responsible for stopping the autotune and a description of the trip.

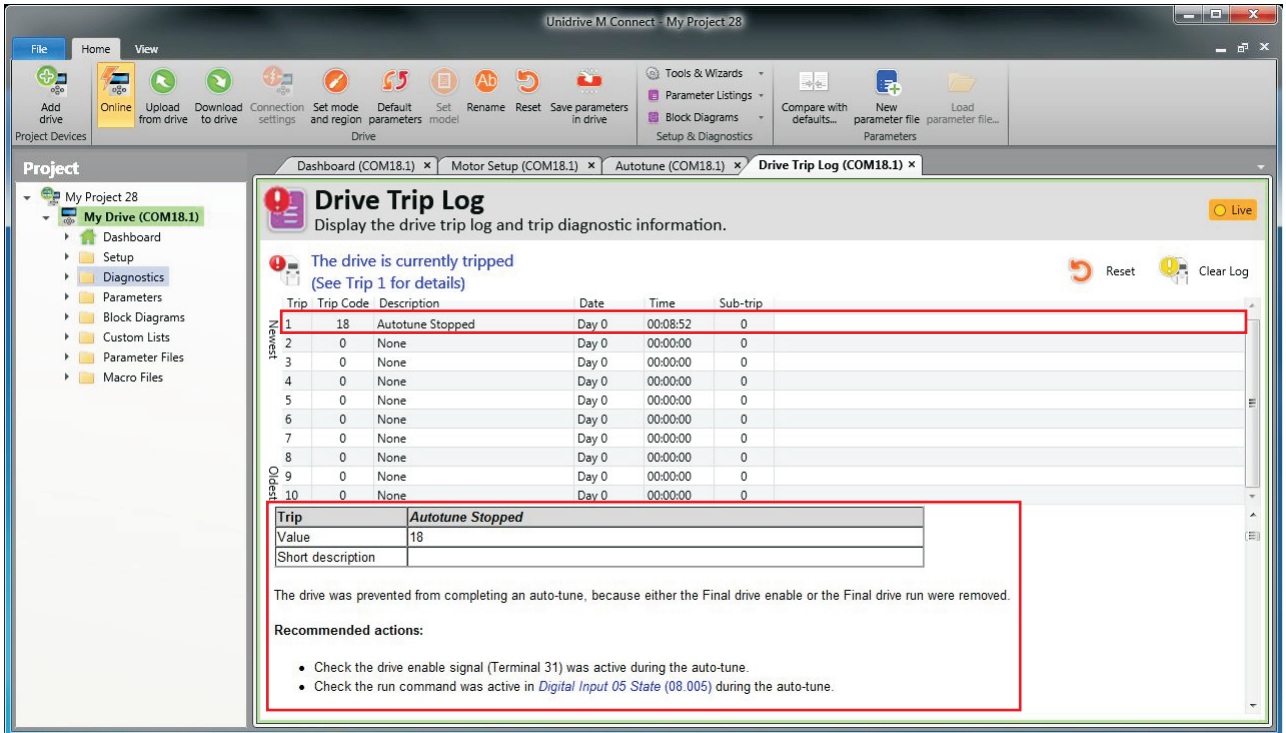

# 7 Optimization

This chapter takes the user through methods of optimizing the drive set-up and maximize the performance. The auto-tuning features of the drive simplify the optimization tasks.

## 7.1 Motor map parameters

### 7.1.1 Open loop motor control

<b>Pr 00.046 {05.007} Rated Current</b>	<b>Defines the maximum continuous motor current</b>
<ul style="list-style-type: none"> <li>The rated current parameter must be set to the maximum continuous current of the motor. (See section 7.2 <i>Maximum motor rated current</i> on page 89, for information about setting this parameter higher than the maximum Heavy Duty current rating). The motor rated current is used in the following: <ul style="list-style-type: none"> <li>Current limits (see section section 7.3 <i>Current limits</i> on page 89, for more information)</li> <li>Motor thermal overload protection (see section 7.4 <i>Motor thermal protection</i> on page 89, for more information)</li> <li>Vector mode voltage control (see <i>Open Loop Control Mode</i> (00.007), later in this table)</li> <li>Slip compensation (see <i>Enable Slip Compensation</i> (05.027), later in this table)</li> <li>Dynamic V/F control</li> </ul> </li> </ul>	
<b>Pr 00.044 {05.009} Rated Voltage</b>	<b>Defines the voltage applied to the motor at rated frequency</b>
<b>Pr 00.047 {05.006} Rated Frequency</b>	<b>Defines the frequency at which rated voltage is applied</b>
<p>The <i>Rated Voltage</i> (00.044) and the <i>Rated Frequency</i> (00.047) are used to define the voltage to frequency characteristic applied to the motor (see <i>Open Loop Control Mode</i> (00.007), later in this table). The <i>Rated Frequency</i> (00.047) is also used in conjunction with the motor rated speed to calculate the rated slip for slip compensation (see <i>Rated Speed</i> (00.045), later in this table).</p>	
<b>Pr 00.045 {05.008} Rated Speed</b>	<b>Defines the full load rated speed of the motor</b>
<b>Pr 00.042 {05.011} Number Of Motor Poles</b>	<b>Defines the number of motor poles</b>
<p>The motor rated speed and the number of poles are used with the motor rated frequency to calculate the rated slip of induction machines in Hz.</p> $\text{Rated slip (Hz)} = \text{Motor rated frequency} - (\text{Number of pole pairs} \times [\text{Motor rated speed} / 60]) = \mathbf{00.047} = \left( \frac{\mathbf{00.042}}{2} \times \frac{\mathbf{00.045}}{60} \right)$ <p>If Pr <b>00.045</b> is set to 0 or to synchronous speed, slip compensation is disabled. If slip compensation is required this parameter should be set to the nameplate value, which should give the correct rpm for a hot machine. Sometimes it will be necessary to adjust this when the drive is commissioned because the nameplate value may be inaccurate. Slip compensation will operate correctly both below base speed and within the field-weakening region. Slip compensation is normally used to correct for the motor speed to prevent speed variation with load. The rated load rpm can be set higher than synchronous speed to deliberately introduce speed droop. This can be useful to aid load sharing with mechanically coupled motors.</p> <p>Pr <b>00.042</b> is also used in the calculation of the motor speed display by the drive for a given output frequency. When Pr <b>00.042</b> is set to 'Automatic', the number of motor poles is automatically calculated from the rated frequency Pr <b>00.047</b>, and the motor rated speed Pr <b>00.045</b>.</p> $\text{Number of poles} = 120 \times (\text{Rated Frequency} (00.047) / \text{Rated Speed} (00.045)) \text{ rounded to the nearest even number.}$	
<b>Pr 00.043 {05.010} Rated Power Factor</b>	<b>Defines the angle between the motor voltage and current</b>
<p>The power factor is the true power factor of the motor, i.e. the angle between the motor voltage and current. The power factor is used in conjunction with the <i>Rated Current</i> (00.046), to calculate the rated active current and magnetising current of the motor. The rated active current is used extensively to control the drive, and the magnetising current is used in vector mode stator resistance compensation. It is important that this parameter is set up correctly. The drive can measure the motor rated power factor by performing a rotating autotune (see <i>Autotune</i> (Pr <b>00.040</b>), below).</p>	

## Pr 0.40 {5.12} Autotune

There are two autotune tests available in open loop mode, a stationary and a rotating test. A rotating autotune should be used whenever possible so the measured value of power factor of the motor is used by the drive.

- A stationary autotune can be used when the motor is loaded and it is not possible to remove the load from the motor shaft. The stationary test measures the *Stator Resistance* (05.017), *Transient Inductance* (05.024), *Maximum Deadtime Compensation* (05.059) and *Current At Maximum Deadtime Compensation* (05.060) which are required for good performance in vector control modes (see *Open Loop Control Mode* (00.007), later in this table). If *Enable Stator Compensation* (05.049) = 1, then *Stator Base Temperature* (05.048) is made equal to *Stator Temperature* (05.046). The stationary autotune does not measure the power factor of the motor so the value on the motor nameplate must be entered into Pr **00.043**. To perform a Stationary autotune, set Pr **00.040** to 1, and provide the drive with both an enable signal (on terminal 31) and a run signal (on terminal 26 or 27).
- A rotating autotune should only be used if the motor is unloaded. A rotating autotune first performs a stationary autotune, as above, then a rotating test is performed in which the motor is accelerated with currently selected ramps up to a frequency of *Rated Frequency* Pr **00.047** {**05.006**} x  $2/3$ , and the frequency is maintained at that level for 4 seconds. *Stator Inductance* (05.025) is measured and this value is used in conjunction with other motor parameters to calculate *Rated Power Factor* (05.010). To perform a Rotating autotune, set Pr **00.040** to 2, and provide the drive with both an enable signal (on terminal 31) and a run signal (on terminal 26 or 27).

Following the completion of an autotune test the drive will go into the inhibit state. The drive must be placed into a controlled disable condition before the drive can be made to run at the required reference. The drive can be put in to a controlled disable condition by removing the Safe Torque Off signal from terminal 31, setting the *Drive Enable* (06.015) to Off (0) or disabling the drive via the *Control Word* (06.042) and *Control Word Enable* (06.043).

## Pr 00.007 {05.014} Open Loop Control Mode

There are several voltage modes available which fall into two categories, vector control and fixed boost.

### Vector control

Vector control mode provides the motor with a linear voltage characteristic from 0 Hz to motor *Rated Frequency* (00.047), and then a constant voltage above motor rated frequency. When the drive operates between motor rated frequency/50 and motor rated frequency/4, full vector based stator resistance compensation is applied. When the drive operates between motor rated frequency/4 and motor rated frequency/2 the stator resistance compensation is gradually reduced to zero as the frequency increases. For the vector modes to operate correctly the *Rated Power Factor* (00.043) and *Stator Resistance* (05.017) are required to be set up accurately. The drive can be made to measure these by performing an autotune (see Pr 00.040 *Autotune*). The drive can also be made to measure the stator resistance automatically every time the drive is enabled or the first time the drive is enabled after it is powered up, by selecting one of the vector control voltage modes.

(0) **Ur S** = The stator resistance is measured and the parameter for the selected motor map is over-written each time the drive is made to run. This test can only be done with a stationary motor where the flux has decayed to zero. Therefore this mode should only be used if the motor is guaranteed to be stationary each time the drive is made to run. To prevent the test from being done before the flux has decayed there is a period of 1 second after the drive has been in the ready state during which the test is not done if the drive is made to run again. In this case, previously measured values are used. Ur S mode ensures that the drive compensates for any change in motor parameters due to changes in temperature. The new value of stator resistance is not automatically saved to the drive's EEPROM.

(1) **Ur** = The stator resistance is not measured. The user can enter the motor and cabling resistance into the *Stator Resistance* (05.017). However this will not include resistance effects within the drive inverter. Therefore if this mode is to be used, it is best to use an autotune test initially to measure the stator resistance.

(3) **Ur\_Auto** = The stator resistance is measured once, the first time the drive is made to run. After the test has been completed successfully the *Open Loop Control Mode* (00.007) is changed to Ur mode. The *Stator Resistance* (05.017) parameter is written to, and along with the *Open Loop Control Mode* (00.007), are saved in the drive's EEPROM. If the test fails, the voltage mode will change to Ur mode but the *Stator Resistance* (05.017) is not updated.

(4) **Ur I** = The stator resistance is measured when the drive is first made to run after each power-up. This test can only be done with a stationary motor. Therefore this mode should only be used if the motor is guaranteed to be stationary the first time the drive is made to run after each power-up. The new value of stator resistance is not automatically saved to the drive's EEPROM.

### Fixed boost

The stator resistance is not used in the control of the motor, instead a fixed characteristic with low frequency voltage boost as defined by Pr **00.008**, is used. Fixed boost mode should be used when the drive is controlling multiple motors. There are two settings of fixed boost available:

(2) **Fixed** = This mode provides the motor with a linear voltage characteristic from 0 Hz to *Rated Frequency* (00.047), and then a constant voltage above rated frequency.

(5) **Square** = This mode provides the motor with a square law voltage characteristic from 0 Hz to *Rated Frequency* (00.047), and then a constant voltage above rated frequency. This mode is suitable for variable torque applications like fans and pumps where the load is proportional to the square of the speed of the motor shaft. This mode should not be used if a high starting torque is required.

### Pr 00.007 {05.014} Open Loop Control Mode (cont)

#### Fixed boost

The stator resistance is not used in the control of the motor, instead a fixed characteristic with low frequency voltage boost as defined by parameter Pr 00.008, is used. Fixed boost mode should be used when the drive is controlling multiple motors. There are two settings of fixed boost available:

(2) **Fixed** = This mode provides the motor with a linear voltage characteristic from 0 Hz to *Rated Frequency* (00.047), and then a constant voltage above rated frequency.

(5) **Square** = This mode provides the motor with a square law voltage characteristic from 0 Hz to *Rated Frequency* (00.047), and then a constant voltage above rated frequency. This mode is suitable for variable torque applications like fans and pumps where the load is proportional to the square of the speed of the motor shaft. This mode should not be used if a high starting torque is required.

For both these modes, at low frequencies (from 0Hz to  $\frac{1}{2} \times$  Pr 00.047) a voltage boost is applied defined by Pr 00.008 as shown below:

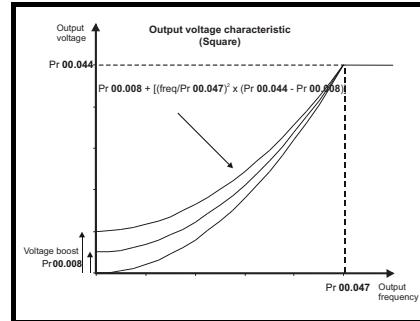
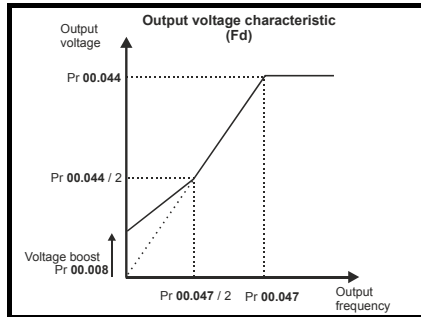

### Pr 05.027 Enable Slip Compensation

When a motor, being controlled in open loop mode, has load applied a characteristic of the motor is that the output speed droops in proportion to the load applied as shown:

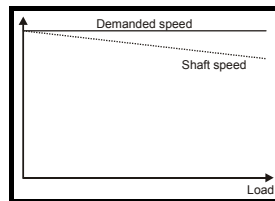

In order to prevent the speed droop shown above slip compensation should be enabled. To enable slip compensation Pr 05.027 must be set to a 1 (this is the default setting), and the motor rated speed must be entered in Pr 00.045 {05.008}.

The motor rated speed parameter should be set to the synchronous speed of the motor minus the slip speed. This is normally displayed on the motor nameplate, i.e. for a typical 18.5 kW, 50 Hz, 4 pole motor, the motor rated speed would be approximately 1465 rpm. The synchronous speed for a 50 Hz, 4 pole motor is 1500 rpm, so therefore the slip speed would be 35 rpm. If the synchronous speed is entered in Pr 00.045, slip compensation will be disabled. If too small a value is entered in Pr 00.045, the motor will run faster than the demanded frequency. The synchronous speeds for 50 Hz motors with different numbers of poles are as follows:

2 pole = 3000 rpm, 4 pole = 1500 rpm, 6pole = 1000 rpm, 8 pole = 750 rpm

## 7.1.2 RFC-A Mode

### Induction motor with position feedback (using SI-Encoder module)

<b>Pr 00.046 {05.007} Motor Rated Current</b>	<b>Defines the maximum motor continuous current</b>
<p>The motor rated current parameter must be set to the maximum continuous current of the motor. (See section 7.2 <i>Maximum motor rated current</i> on page 89, for information about setting this parameter higher than the maximum Heavy Duty current rating.) The motor rated current is used in the following:</p> <ul style="list-style-type: none"> <li>• Current limits (see section 7.3 <i>Current limits</i> on page 89, for more information).</li> <li>• Motor thermal overload protection (see section 7.4 <i>Motor thermal protection</i> on page 89, for more information)</li> <li>• Vector control algorithm</li> </ul>	
<b>Pr 00.044 {05.009} Rated Voltage</b>	<b>Defines the voltage applied to the motor at rated frequency</b>
<b>Pr 00.047 {05.006} Rated Frequency</b>	<b>Defines the frequency at which rated voltage is applied</b>
<p>The <i>Rated Voltage</i> (00.044) and the <i>Rated Frequency</i> (00.047) are used to define the voltage to frequency characteristic applied to the motor (see <i>Open Loop Control Mode</i> (00.007), later in this table). The motor rated frequency is also used in conjunction with the motor rated speed to calculate the rated slip for slip compensation (see motor <i>Rated Speed</i> (00.045), later in this table).</p>	
<p>The graph, titled "Output voltage characteristic", plots Output voltage on the vertical axis against Output frequency on the horizontal axis. A solid line starts at the origin (0,0) and rises linearly. A dashed horizontal line from the y-axis at Pr 00.044 / 2 meets the line at a frequency of Pr 00.047 / 2. The line continues to a frequency of Pr 00.047, where it reaches a voltage of Pr 00.044. From this point, the line becomes horizontal, extending to the right. Dashed lines indicate the coordinates of these key points on the graph.</p>	
<b>Pr 00.045 {05.008} Rated Speed</b>	<b>Defines the full load rated speed of the motor</b>
<b>Pr 00.042 {05.011} Number Of Motor Poles</b>	<b>Defines the number of motor poles</b>
<p>The motor rated speed and motor rated frequency are used to determine the full load slip of the motor which is used by the vector control algorithm. Incorrect setting of this parameter has the following effects:</p> <ul style="list-style-type: none"> <li>• Reduced efficiency of motor operation</li> <li>• Reduction of maximum torque available from the motor</li> <li>• Reduced transient performance</li> <li>• Inaccurate control of absolute torque in torque control modes</li> </ul> <p>The nameplate value is normally the value for a hot motor; however, some adjustment may be required when the drive is commissioned if the nameplate value is inaccurate. Either a fixed value can be entered in this parameter or an optimization system may be used to automatically adjust this parameter (see <i>Rated Speed Optimization Select</i> Pr 00.033 {05.016}, later in this table).</p> <p>When Pr 00.042 is set to 'Automatic', the number of motor poles is automatically calculated from the motor <i>Rated Frequency</i> (00.047), and the motor <i>Rated Speed</i> (00.045).</p> <p>Number of poles = <math>120 \times (\text{Motor Rated Frequency (00.047)} / \text{Motor Rated Speed (00.045)})</math> rounded to the nearest even number.</p>	
<b>Pr 00.043 {5.010} Rated Power Factor</b>	<b>Defines the angle between the motor voltage and current</b>
<p>The power factor is the true power factor of the motor, i.e. the angle between the motor voltage and current. If the <i>Stator Inductance</i> (05.025) is set to zero then the power factor is used in conjunction with the motor <i>Rated Current</i> (00.046) and other motor parameters to calculate the rated active and magnetising currents of the motor, which are used in the vector control algorithm. If the stator inductance has a non-zero value this parameter is not used by the drive, but is continuously written with a calculated value of power factor. The stator inductance can be measured by the drive by performing a rotating autotune (see <i>Autotune</i> (Pr 00.040), later in this table).</p>	

## Pr 00.040 {05.012} Autotune

There are four autotune tests available in RFC-A mode, a stationary test, a rotating test and two inertia measurement tests. A stationary autotune will give moderate performance whereas a rotating autotune will give improved performance as it measures the actual values of the motor parameters required by the drive. An inertia measurement test should be performed separately to a stationary or rotating autotune.

It is highly recommended that a rotating autotune is performed (Pr 00.040 set to 2).

- A stationary autotune can be used when the motor is loaded and it is not possible to remove the load from the motor shaft. The stationary autotune measures the *Stator Resistance* (05.017) and *Transient Inductance* (05.024) of the motor. These are used to calculate the current loop gains, and at the end of the test the values in Pr 00.038 {04.013} and Pr 00.039 {04.014} are updated. *Maximum Deadtime Compensation* (05.059) and *Current At Maximum Deadtime Compensation* (05.060) for the drive are also measured. Additionally, if *Enable Stator Compensation* (05.049) = 1, then *Stator Base Temperature* (05.048) is made equal to *Stator Temperature* (05.046). A stationary autotune does not measure the power factor of the motor so the value on the motor nameplate must be entered into Pr 00.043. To perform a stationary autotune, set Pr 00.040 to 1, and provide the drive with both an enable signal (on terminal 31) and a run signal (on terminal 26 or 27).
- A rotating autotune should only be used if the motor is unloaded. A rotating autotune first performs a stationary autotune, a rotating test is then performed in which the motor is accelerated with currently selected ramps up to a frequency of *Rated Frequency* Pr 00.047 {05.006} x 2/3, and the frequency is maintained at the level for up to 40 s. During the rotating autotune the *Stator Inductance* (05.025), and the motor saturation breakpoints (Pr 05.029, Pr 05.030, Pr 06.062 and Pr 05.063) are modified by the drive. The power factor is also modified for user information only, but is not used after this point as the stator inductance is used in the vector control algorithm instead. To perform a Rotating autotune, set Pr 00.040 to 2, and provide the drive with both an enable signal (on terminal 31) and a run signal (on terminal 26 or 27).
- The inertia measurement test can measure the total inertia of the load and the motor. This is used to set the speed loop gains (see Speed loop gains) and to provide torque feed-forwards when required during acceleration.

Two tests are available:

**Signal injection (when using an SI-Encoder module)** This test measures the mechanical characteristic of the motor and load by rotating the motor at the speed defined by the present speed reference and injecting a series of speed test signals. This test should only be used provided all the basic control parameters have been set-up correctly and the speed controller parameters should be set to conservative levels, such as the default values, so that the motor is stable when it runs. If *Mechanical Load Test Level* (05.021) is left at its default value of zero then the peak level of the injection signal will be 1 % of the maximum speed reference subject to a maximum of 500 rpm. If a different test level is required then *Mechanical Load Test Level* (05.021) should be set to a non-zero value to define the level as a percentage of the maximum speed reference, again subject to a maximum of 500 rpm. The user defined speed reference which defines the speed of the motor should be set to a level higher than the test level, but not high enough for flux weakening to become active. In some cases however, it is possible to perform the test at zero speed provided the motor is free to move, but it may be necessary to increase the test signal from the default value. The test will give the correct results when there is a static load applied to the motor and in the presence of mechanical damping. To perform an Inertia measurement autotune, set Pr 00.040 to 3, and provide the drive with both an enable signal (on terminal 31) and a run signal (on terminal 26 or 27).

If the speed controller cannot be set up for stable operation an alternative test is provided, where a series of torque levels are applied to accelerate and decelerate the motor to measure the inertia.

**Applied torque (sensorless mode)** This test may give inaccurate results, if the motor rated speed is not set to the correct value for the motor, or if standard ramp mode is active. During the inertia measurement test a series of progressively larger torque levels are applied to the motor (20 %, 40 % ... 100 % of rated torque) to accelerate the motor up to  $\frac{3}{4} \times \text{Rated Speed}$  Pr 00.045 {05.008} to determine the inertia from the acceleration/deceleration time. The test attempts to reach the required speed within 5 s, but if this fails the next torque level is used. When 100 % torque is used the test allows 60 s for the required speed to be reached, but if this is unsuccessful an Autotune trip is initiated. To reduce the time taken for the test it is possible to define the level of torque to be used for the test by setting *Mechanical Load Test Level* (05.021) to a non-zero value. When the test level is defined the test is only carried out at the defined test level and 60 s is allowed for the motor to reach the required speed. It should be noted that if the maximum speed allows for flux weakening then it may not be possible to achieve the required torque level to accelerate the motor quickly enough. If this is the case, the maximum speed reference should be reduced. To perform an Inertia measurement autotune, set Pr 00.040 to 3, and provide the drive with both an enable signal (on terminal 31) and a run signal (on terminal 26 or 27).

Following the completion of an autotune test the drive will go into the inhibit state. The drive must be placed into a controlled disable condition before the drive can be made to run at the required reference. The drive can be put in to a controlled disable condition by removing the Safe Torque Off signal from terminal 31, setting the *Drive Enable* (06.015) to Off (0) or disabling the drive via the control word (Pr 06.042 & Pr 06.043)

## Pr 00.033 {05.016} Rated Speed Optimization Select

(When using an SI-Encoder option module)

The motor *Rated Speed* (00.045) in conjunction with the motor *Rated Frequency* (00.047) defines the full load slip of the motor. The slip is used in the motor model for RFC-A control. The full load slip of the motor varies with rotor resistance which can vary significantly with motor temperature. When Pr 00.033 {05.016} is set to 1 or 2 the drive can automatically sense if the value of slip defined by Pr 00.047 and Pr 00.045 has been set incorrectly or if it has varied with motor temperature. If the value is incorrect Pr 00.045 is automatically adjusted. Pr 00.045 is not saved at power-down, and so when the drive is powered-down and up again it will return to the last saved value. If the new value is required at the next power-up it must be saved by the user.

The adaptive control system is only enabled when the  $|\text{Output Frequency Pr 00.011 \{05.001\}}|$  is above  $\text{Rated Frequency Pr 00.047 \{05.006\}} / 8$ , and the  $|\text{Percentage Load (04.020)}|$  is greater than 60 %. The adaptive control system is disabled again if the  $|\text{Percentage Load (04.020)}|$  falls below 50 %. For best optimization results the correct values of *Stator Resistance* (05.017), *Transient Inductance* (05.024), *Stator Inductance* (05.025), *Saturation Breakpoint 1* (05.029), *Saturation Breakpoint 2* (05.062), *Saturation Breakpoint 3* (05.030) and *Saturation Breakpoint 4* (05.063) should be used.

If *Rated Speed Optimization Select* Pr 00.033 {05.016} = 1 the gain of the adaptive control system is low and hence the rate at which it converges is slow. If *Rated Speed Optimization Select* Pr 00.033 {05.016} = 2 the gain is increased by a factor of 16 and the convergence rate is increased.

**Pr 00.038 {04.013} / Pr 00.039 {04.014} Current Loop Gains**

The current loop gains proportional (Kp) and integral (Ki) gains control the response of the current loop to a change in current (torque) demand. The default values give satisfactory operation with most motors. However, for optimal performance in dynamic applications it may be necessary to change the gains to improve the performance. The *Current Controller Kp Gain* Pr **00.038 {04.013}** is the most critical value in controlling the performance. The values for the current loop gains can be calculated by performing a stationary or rotating autotune (see *Autotune* Pr 00.040, earlier in this table) the drive measures the *Stator Resistance* (05.017) and *Transient Inductance* (05.024) of the motor and calculates the current loop gains.

This will give a step response with minimum overshoot after a step change of current reference. The proportional gain can be increased by a factor of 1.5 giving a similar increase in bandwidth; however, this gives a step response with approximately 12.5 % overshoot. The equation for the integral gain gives a conservative value. In some applications where it is necessary for the reference frame used by the drive to dynamically follow the flux very closely (i.e. high speed Sensorless RFC-A induction motor applications) the integral gain may need to have a significantly higher value.

### Speed Loop Gains (Pr 00.007 {03.010}, Pr 00.008 {03.011}, Pr 00.009 {03.012})

The speed loop gains control the response of the speed controller to a change in speed demand. The speed controller includes proportional (Kp) and integral (Ki) feed forward terms, and a differential (Kd) feedback term. The drive holds two sets of these gains and either set may be selected for use by the speed controller with Pr 03.016. If Pr 03.016 = 0, gains Kp1, Ki1 and Kd1 (Pr 00.007 to Pr 00.009) are used, and if Pr 03.016 = 1, gains Kp2, Ki2 and Kd2 (Pr 03.013 to Pr 03.015) are used. Pr 03.016 may be changed when the drive is enabled or disabled. If the load is predominantly a constant inertia and constant torque, the drive can calculate the required Kp and Ki gains to give a required compliance angle or bandwidth dependant on the setting of Pr 03.017.

#### Speed Controller Proportional Gain (Kp), Pr 00.007 {03.010} and Pr 03.013

If the proportional gain has a value and the integral gain is set to zero the controller will only have a proportional term, and there must be a speed error to produce a torque reference. Therefore as the motor load increases there will be a difference between the reference and actual speeds. This effect, called regulation, depends on the level of the proportional gain, the higher the gain the smaller the speed error for a given load. If the proportional gain is too high either the acoustic noise produced by speed feedback quantization becomes unacceptable, or the stability limit is reached.

#### Speed Controller Integral Gain (Ki), Pr 00.008 {03.011} and Pr 03.014

The integral gain is provided to prevent speed regulation. The error is accumulated over a period of time and used to produce the necessary torque demand without any speed error. Increasing the integral gain reduces the time taken for the speed to reach the correct level and increases the stiffness of the system, i.e. it reduces the positional displacement produced by applying a load torque to the motor. Unfortunately increasing the integral gain also reduces the system damping giving overshoot after a transient. For a given integral gain the damping can be improved by increasing the proportional gain. A compromise must be reached where the system response, stiffness and damping are all adequate for the application. For RFC-A Sensorless mode, it is unlikely that the integral gain can be increased much above 0.50.

#### Differential Gain (Kd), Pr 00.009 {03.012} and Pr 03.015

The differential gain is provided in the feedback of the speed controller to give additional damping. The differential term is implemented in a way that does not introduce excessive noise normally associated with this type of function. Increasing the differential term reduces the overshoot produced by under-damping, however, for most applications the proportional and integral gains alone are sufficient.

There are six methods of tuning the speed loop gains dependant on the setting of Pr 03.017:

- Pr 03.017 = 0, User set-up.  
This involves the connecting of an oscilloscope to analog output 1 to monitor the speed feedback.  
Give the drive a step change in speed reference and monitor the response of the drive on the oscilloscope.  
The proportional gain (Kp) should be set up initially. The value should be increased up to the point where the speed overshoots and then reduced slightly.  
The integral gain (Ki) should then be increased up to the point where the speed becomes unstable and then reduced slightly.  
It may now be possible to increase the proportional gain to a higher value and the process should be repeated until the system response matches the ideal response as shown.  
The diagram shows the effect of incorrect P and I gain settings as well as the ideal response.
- Pr 03.017 = 1, Bandwidth set-up  
If bandwidth based set-up is required, the drive can calculate Kp and Ki if the following parameters are set up correctly:  
Pr 03.020 - Required bandwidth,  
Pr 03.021 - Required damping factor,  
Pr 03.018 - Motor and load inertia.  
The drive can be made to measure the motor and load inertia by performing an inertia measurement autotune (see Autotune Pr 00.040, earlier in this table).
- Pr 03.017 = 2, Compliance angle set-up  
If compliance angle based set-up is required, the drive can calculate Kp and Ki if the following parameters are set up correctly:  
Pr 03.019 - Required compliance angle,  
Pr 03.021 - Required damping factor,  
Pr 03.018 - Motor and load inertia  
The drive can be made to measure the motor and load inertia by performing an inertia measurement autotune (see Autotune Pr 00.040, earlier in this table).
- Pr 03.017 = 3, Kp gains times 16  
If Speed Controller Set-up Method (03.017) = 3 the selected proportional gain used by the drive is multiplied by 16.

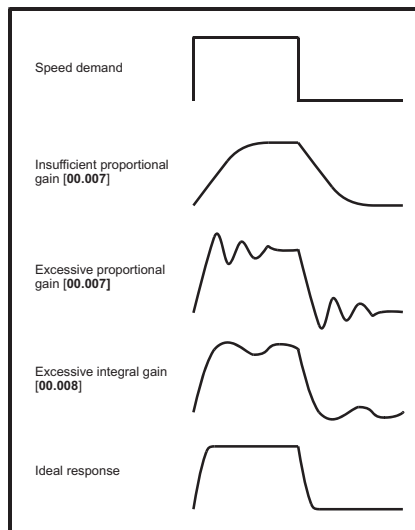

#### 5. Pr 03.017 = 4 - 6

If Speed Controller Set-up Method (03.017) is set to a value from 4 to 6 the Speed Controller Proportional Gain Kp1 Pr 00.007 {03.010} and Speed Controller Integral Gain Ki1 Pr 00.008 {03.011} are automatically set up to give the bandwidths given in the table below and a damping factor of unity. These settings give low, standard or high performance.

Pr 03.017	Performance	Bandwidth
4	Low	5 Hz
5	Standard	25 Hz
6	High	100 Hz

#### 6. Pr 03.017 = 7

If Speed Controller Set-up Method (03.017) = 7 then Speed Controller Proportional Gain Kp1 Pr 00.007 {03.010}, Speed Controller Integral Gain Ki1 Pr 00.008 {03.011} and Speed Controller Differential Feedback Gain Kd1 Pr 00.009 {03.012} are set up to give a closed-loop speed controller response that approximates to a first order system with a transfer function of  $1 / (s\tau + 1)$ , where  $\tau = 1/\omega_{bw}$  and  $\omega_{bw} = 2\pi \times \text{Bandwidth}$  (03.020). In this case the damping factor is meaningless, and Damping Factor (03.021) and Compliance Angle (03.019) have no effect.

### 7.1.3 RFC-A Sensorless mode

#### Induction motor without position feedback

<b>Pr 00.046 {05.007} Motor Rated Current</b>	<b>Defines the maximum motor continuous current</b>
<p>The motor rated current parameter must be set to the maximum continuous current of the motor. (See section 7.2 <i>Maximum motor rated current</i> on page 89, for information about setting this parameter higher than the maximum Heavy Duty current rating.) The motor rated current is used in the following:</p> <ul style="list-style-type: none"> <li>• Current limits (see section 7.3 <i>Current limits</i> on page 89, for more information).</li> <li>• Motor thermal overload protection (see section 7.4 <i>Motor thermal protection</i> on page 89, for more information)</li> <li>• Vector control algorithm</li> </ul>	
<b>Pr 00.044 {05.009} Rated Voltage</b>	<b>Defines the voltage applied to the motor at rated frequency</b>
<b>Pr 00.047 {05.006} Rated Frequency</b>	<b>Defines the frequency at which rated voltage is applied</b>
<p>The <i>Rated Voltage</i> (00.044) and the <i>Rated Frequency</i> (00.047) are used to define the voltage to frequency characteristic applied to the motor (see <i>Open Loop Control Mode</i> (00.007), later in this table). The motor rated frequency is also used in conjunction with the motor rated speed to calculate the rated slip for slip compensation (see motor <i>Rated Speed</i> (00.045), later in this table).</p>	
	<p>The graph, titled "Output voltage characteristic", plots Output voltage on the vertical axis against Output frequency on the horizontal axis. A solid line starts at the origin and rises linearly to a point where the frequency is Pr 00.047 and the voltage is Pr 00.044. From this point, the line becomes horizontal, indicating constant output voltage. Dotted lines indicate that at a frequency of Pr 00.047 / 2, the output voltage is Pr 00.044 / 2.</p>
<b>Pr 00.045 {05.008} Rated Speed</b>	<b>Defines the full load rated speed of the motor</b>
<b>Pr 00.042 {05.011} Number Of Motor Poles</b>	<b>Defines the number of motor poles</b>
<p>The motor rated speed and motor rated frequency are used to determine the full load slip of the motor which is used by the vector control algorithm. Incorrect setting of this parameter has the following effects:</p> <ul style="list-style-type: none"> <li>• Reduced efficiency of motor operation</li> <li>• Reduction of maximum torque available from the motor</li> <li>• Reduced transient performance</li> <li>• Inaccurate control of absolute torque in torque control modes</li> </ul> <p>The nameplate value is normally the value for a hot motor; however, some adjustment may be required when the drive is commissioned if the nameplate value is inaccurate. Either a fixed value can be entered in this parameter or an optimization system may be used to automatically adjust this parameter (see <i>Rated Speed Optimization Select</i> Pr 00.033 {05.016}, later in this table).</p> <p>When Pr 00.042 is set to 'Automatic', the number of motor poles is automatically calculated from the motor <i>Rated Frequency</i> (00.047), and the motor <i>Rated Speed</i> (00.045).</p> <p>Number of poles = 120 x (Motor <i>Rated Frequency</i> (00.047 / Motor <i>Rated Speed</i> (00.045) rounded to the nearest even number.</p>	
<b>Pr 00.043 {5.010} Rated Power Factor</b>	<b>Defines the angle between the motor voltage and current</b>
<p>The power factor is the true power factor of the motor, i.e. the angle between the motor voltage and current. If the <i>Stator Inductance</i> (05.025) is set to zero then the power factor is used in conjunction with the motor <i>Rated Current</i> (00.046) and other motor parameters to calculate the rated active and magnetising currents of the motor, which are used in the vector control algorithm. If the stator inductance has a non-zero value this parameter is not used by the drive, but is continuously written with a calculated value of power factor. The stator inductance can be measured by the drive by performing a rotating autotune (see <i>Autotune</i> (Pr 00.040), later in this table).</p>	

## Pr 00.040 {05.012} Autotune

There are three autotune tests available in RFC-A mode, a stationary test, a rotating test and an inertia measurement test. A stationary autotune will give moderate performance whereas a rotating autotune will give improved performance as it measures the actual values of the motor parameters required by the drive. An inertia measurement test should be performed separately to a stationary or rotating autotune.

It is highly recommended that a rotating autotune is performed (Pr 00.040 set to 2).

- A stationary autotune can be used when the motor is loaded and it is not possible to remove the load from the motor shaft. The stationary autotune measures the *Stator Resistance* (05.017) and *Transient Inductance* (05.024) of the motor. These are used to calculate the current loop gains, and at the end of the test the values in Pr 00.038 {04.013} and Pr 00.039 {04.014} are updated. *Maximum Deadtime Compensation* (05.059) and *Current At Maximum Deadtime Compensation* (05.060) for the drive are also measured. Additionally, if *Enable Stator Compensation* (05.049) = 1, then *Stator Base Temperature* (05.048) is made equal to *Stator Temperature* (05.046). A stationary autotune does not measure the power factor of the motor so the value on the motor nameplate must be entered into Pr 00.043. To perform a stationary autotune, set Pr 00.040 to 1, and provide the drive with both an enable signal (on terminal 31) and a run signal (on terminal 26 or 27).
- A rotating autotune should only be used if the motor is unloaded. A rotating autotune first performs a stationary autotune, a rotating test is then performed in which the motor is accelerated with currently selected ramps up to a frequency of *Rated Frequency* Pr 00.047 {05.006} x 2/3, and the frequency is maintained at the level for up to 40 s. During the rotating autotune the *Stator Inductance* (05.025), and the motor saturation breakpoints (Pr 05.029, Pr 05.030, Pr 06.062 and Pr 05.063) are modified by the drive. The power factor is also modified for user information only, but is not used after this point as the stator inductance is used in the vector control algorithm instead. To perform a Rotating autotune, set Pr 00.040 to 2, and provide the drive with both an enable signal (on terminal 31) and a run signal (on terminal 26 or 27).
- The inertia measurement test can measure the total inertia of the load and the motor. This is used to set the speed loop gains (see Speed loop gains) and to provide torque feed-forwards when required during acceleration.

**Applied torque (sensorless mode)** This test may give inaccurate results, if the motor rated speed is not set to the correct value for the motor, or if standard ramp mode is active. During the inertia measurement test a series of progressively larger torque levels are applied to the motor (20 %, 40 % ... 100 % of rated torque) to accelerate the motor up to  $\frac{3}{4} \times \text{Rated Speed}$  Pr 00.045 {05.008} to determine the inertia from the acceleration/deceleration time. The test attempts to reach the required speed within 5 s, but if this fails the next torque level is used. When 100 % torque is used the test allows 60 s for the required speed to be reached, but if this is unsuccessful an Autotune trip is initiated. To reduce the time taken for the test it is possible to define the level of torque to be used for the test by setting *Mechanical Load Test Level* (05.021) to a non-zero value. When the test level is defined the test is only carried out at the defined test level and 60 s is allowed for the motor to reach the required speed. It should be noted that if the maximum speed allows for flux weakening then it may not be possible to achieve the required torque level to accelerate the motor quickly enough. If this is the case, the maximum speed reference should be reduced. To perform an Inertia measurement autotune, set Pr 00.040 to 4, and provide the drive with both an enable signal (on terminal 31) and a run signal (on terminal 26 or 27).

Following the completion of an autotune test the drive will go into the inhibit state. The drive must be placed into a controlled disable condition before the drive can be made to run at the required reference. The drive can be put in to a controlled disable condition by removing the Safe Torque Off signal from terminal 31, setting the *Drive Enable* (06.015) to Off (0) or disabling the drive via the control word (Pr 06.042 & Pr 06.043)

## Pr 00.038 {04.013} / Pr 00.039 {04.014} Current Loop Gains

The current loop gains proportional (Kp) and integral (Ki) gains control the response of the current loop to a change in current (torque) demand. The default values give satisfactory operation with most motors. However, for optimal performance in dynamic applications it may be necessary to change the gains to improve the performance. The *Current Controller Kp Gain* Pr 00.038 {04.013} is the most critical value in controlling the performance. The values for the current loop gains can be calculated by performing a stationary or rotating autotune (see *Autotune* Pr 00.040, earlier in this table) the drive measures the *Stator Resistance* (05.017) and *Transient Inductance* (05.024) of the motor and calculates the current loop gains.

This will give a step response with minimum overshoot after a step change of current reference. The proportional gain can be increased by a factor of 1.5 giving a similar increase in bandwidth; however, this gives a step response with approximately 12.5 % overshoot. The equation for the integral gain gives a conservative value. In some applications where it is necessary for the reference frame used by the drive to dynamically follow the flux very closely (i.e. high speed Sensorless RFC-A induction motor applications) the integral gain may need to have a significantly higher value.

### Speed Loop Gains (Pr 00.007 {03.010}, Pr 00.008 {03.011}, Pr 00.009 {03.012})

The speed loop gains control the response of the speed controller to a change in speed demand. The speed controller includes proportional (Kp) and integral (Ki) feed forward terms, and a differential (Kd) feedback term. The drive holds two sets of these gains and either set may be selected for use by the speed controller with Pr 03.016. If Pr 03.016 = 0, gains Kp1, Ki1 and Kd1 (Pr 00.007 to Pr 00.009) are used, and if Pr 03.016 = 1, gains Kp2, Ki2 and Kd2 (Pr 03.013 to Pr 03.015) are used. Pr 03.016 may be changed when the drive is enabled or disabled. If the load is predominantly a constant inertia and constant torque, the drive can calculate the required Kp and Ki gains to give a required compliance angle or bandwidth dependant on the setting of Pr 03.017.

#### Speed Controller Proportional Gain (Kp), Pr 00.007 {03.010} and Pr 03.013

If the proportional gain has a value and the integral gain is set to zero the controller will only have a proportional term, and there must be a speed error to produce a torque reference. Therefore as the motor load increases there will be a difference between the reference and actual speeds. This effect, called regulation, depends on the level of the proportional gain, the higher the gain the smaller the speed error for a given load. If the proportional gain is too high either the acoustic noise produced by speed feedback quantization becomes unacceptable, or the stability limit is reached.

#### Speed Controller Integral Gain (Ki), Pr 00.008 {03.011} and Pr 03.014

The integral gain is provided to prevent speed regulation. The error is accumulated over a period of time and used to produce the necessary torque demand without any speed error. Increasing the integral gain reduces the time taken for the speed to reach the correct level and increases the stiffness of the system, i.e. it reduces the positional displacement produced by applying a load torque to the motor. Unfortunately increasing the integral gain also reduces the system damping giving overshoot after a transient. For a given integral gain the damping can be improved by increasing the proportional gain. A compromise must be reached where the system response, stiffness and damping are all adequate for the application. For RFC-A Sensorless mode, it is unlikely that the integral gain can be increased much above 0.50.

#### Differential Gain (Kd), Pr 00.009 {0 3.012} and Pr 03.015

The differential gain is provided in the feedback of the speed controller to give additional damping. The differential term is implemented in a way that does not introduce excessive noise normally associated with this type of function. Increasing the differential term reduces the overshoot produced by under-damping, however, for most applications the proportional and integral gains alone are sufficient.

There are six methods of tuning the speed loop gains dependant on the setting of Pr 03.017:

- Pr 03.017 = 0, User set-up.  
This involves the connecting of an oscilloscope to analog output 1 to monitor the speed feedback.  
Give the drive a step change in speed reference and monitor the response of the drive on the oscilloscope.  
The proportional gain (Kp) should be set up initially. The value should be increased up to the point where the speed overshoots and then reduced slightly.  
The integral gain (Ki) should then be increased up to the point where the speed becomes unstable and then reduced slightly.  
It may now be possible to increase the proportional gain to a higher value and the process should be repeated until the system response matches the ideal response as shown.  
The diagram shows the effect of incorrect P and I gain settings as well as the ideal response.
- Pr 03.017 = 1, Bandwidth set-up  
If bandwidth based set-up is required, the drive can calculate Kp and Ki if the following parameters are set up correctly:  
Pr 03.020 - Required bandwidth,  
Pr 03.021 - Required damping factor,  
Pr 03.018 - Motor and load inertia.  
The drive can be made to measure the motor and load inertia by performing an inertia measurement autotune (see Autotune Pr 00.040, earlier in this table).
- Pr 03.017 = 2, Compliance angle set-up  
If compliance angle based set-up is required, the drive can calculate Kp and Ki if the following parameters are set up correctly:  
Pr 03.019 - Required compliance angle,  
Pr 03.021 - Required damping factor,  
Pr 03.018 - Motor and load inertia  
The drive can be made to measure the motor and load inertia by performing an inertia measurement autotune (see Autotune Pr 00.040, earlier in this table).
- Pr 03.017 = 3, Kp gains times 16  
If Speed Controller Set-up Method (03.017) = 3 the selected proportional gain used by the drive is multiplied by 16.

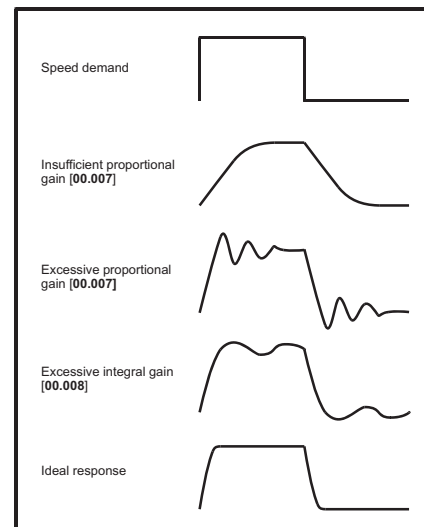

#### 5. Pr 03.017 = 4 - 6

If Speed Controller Set-up Method (03.017) is set to a value from 4 to 6 the Speed Controller Proportional Gain Kp1 Pr 00.007 {03.010} and Speed Controller Integral Gain Ki1 Pr 00.008 {03.011} are automatically set up to give the bandwidths given in the table below and a damping factor of unity. These settings give low, standard or high performance.

Pr 03.017	Performance	Bandwidth
4	Low	5 Hz
5	Standard	25 Hz
6	High	100 Hz

#### 6. Pr 03.017 = 7

If Speed Controller Set-up Method (03.017) = 7 then Speed Controller Proportional Gain Kp1 Pr 00.007 {03.010}, Speed Controller Integral Gain Ki1 Pr 00.008 {03.011} and Speed Controller Differential Feedback Gain Kd1 Pr 00.009 {03.012} are set up to give a closed-loop speed controller response that approximates to a first order system with a transfer function of  $1 / (\tau s + 1)$ , where  $\tau = 1 / \omega_{bw}$  and  $\omega_{bw} = 2\pi \times \text{Bandwidth}$  (03.020). In this case the damping factor is meaningless, and Damping Factor (03.021) and Compliance Angle (03.019) have no effect.

## 7.1.4 RFC-S Sensorless mode

### Permanent magnet motor without Position feedback

#### Pr 00.046 {05.007} Rated Current

Defines the maximum motor continuous current

The motor rated current parameter must be set to the maximum continuous current of the motor. The motor rated current is used in the following:

- Current limits (see section 7.3 *Current limits* on page 89, for more information)
- Motor thermal overload protection (see section 7.4 *Motor thermal protection* on page 89, for more information)

#### Pr 00.042 {05.011} Number Of Motor Poles

Defines the number of motor poles

The number of motor poles parameter defines the number of electrical revolutions in one whole mechanical revolution of the motor. This parameter must be set correctly for the control algorithms to operate correctly. When Pr 00.042 is set to "Automatic" the number of poles is 6.

#### Pr 00.040 {05.012} Autotune

There are three autotune tests available in RFC-S sensorless mode, a stationary autotune and an inertia measurement test.

- Stationary Autotune (Pr 00.040 {05.012} = 1)

The stationary autotune can be used to measure all the necessary parameters for basic control. The tests measures *Stator Resistance* (05.017), *Ld* (05.024), *No Load Lq* Pr 00.056 {05.072}, *Maximum Deadtime Compensation* (05.059) and *Current At Maximum Deadtime Compensation* (05.060). If *Enable Stator Compensation* (05.049) = 1 then *Stator Base Temperature* (05.048) is made equal to *Stator Temperature* (05.046). The *Stator Resistance* (05.017) and *Ld* (05.024) are then used to set up *Current controller Kp Gain* Pr 00.038 {04.013} and *Current Controller Ki Gain* Pr 00.039 {04.014}. To perform a Stationary autotune, set Pr 00.040 to 1, and provide the drive with both an enable signal (on terminal 31) and a run signal (on terminal 26 or 27).

- Rotating Autotune (Pr 00.040 {05.012} = 2)

In sensorless mode, if Rotating autotune is selected (Pr 00.040 = 2), then a stationary autotune is performed.

- Inertia measurement test (Pr 00.040 {05.012} = 4)

**NOTE:** It is not possible to perform this test if, after autotune, the ratio *No load Lq* Pr 00.056 {05.072} / *Ld* (05.024) < 1.1 and Pr 00.054 {05.064} has been set to Non-salient.

The inertia measurement test can measure the total inertia of the load and the motor. This is used to set the speed loop gains (see Speed loop gains) and to provide torque feed-forwards when required during acceleration. The test may give inaccurate results, if the motor rated speed is not set to the correct value for the motor, or if standard ramp mode is active. During the inertia measurement test a series of progressively larger torque levels are applied to the motor (20 %, 40 % ... 100 % of rated torque) to accelerate the motor up to  $\frac{3}{4} \times \text{Rated Speed}$  Pr 00.045 {05.008} to determine the inertia from the acceleration/deceleration time. The test attempts to reach the required speed within 5 s, but if this fails the next torque level is used. When 100 % torque is used the test allows 60 s for the required speed to be reached, but if this is unsuccessful an Autotune trip is initiated. To reduce the time taken for the test it is possible to define the level of torque to be used for the test by setting *Mechanical Load Test Level* (05.021) to a non-zero value. When the test level is defined the test is only carried out at the defined test level and 60 s is allowed for the motor to reach the required speed. It should be noted that if the maximum speed allows for flux weakening then it may not be possible to achieve the required torque level to accelerate the motor quickly enough. If this is the case, the maximum speed reference should be reduced. To perform an Inertia measurement autotune, set Pr 00.040 to 4, and provide the drive with both an enable signal (on terminal 31) and a run signal (on terminal 26 or 27).

Following the completion of an autotune test the drive will go into the inhibit state. The drive must be placed into a controlled disable condition before the drive can be made to run at the required reference. The drive can be put in to a controlled disable condition by removing the Safe Torque Off signal from terminal 31, setting the drive Enable Parameter (06.015) to Off (0) or disabling the drive via the control word (Pr 06.042 & Pr 06.043).

#### Pr 00.038 {04.013} / Pr 00.039 {04.014} Current Loop Gains

The current loop gains proportional (Kp) and integral (Ki) gains control the response of the current loop to a change in current (torque) demand. The default values give satisfactory operation with most motors. However, for optimal performance in dynamic applications it may be necessary to change the gains to improve the performance. The proportional gain Pr 00.038 {04.013} is the most critical value in controlling the performance. The values for the current loop gains can be calculated by performing a stationary or rotating autotune (see *Autotune* Pr 00.040, earlier in this table) the drive measures the *Stator Resistance* (05.017) and *Transient Inductance* (05.024) of the motor and calculates the current loop gains.

This will give a step response with minimum overshoot after a step change of current reference. The proportional gain can be increased by a factor of 1.5 giving a similar increase in bandwidth; however, this gives a step response with approximately 12.5 % overshoot. The equation for the integral gain gives a conservative value. In some applications where it is necessary for the reference frame used by the drive to dynamically follow the flux very closely the integral gain may need to have a significantly higher value.

### Speed Loop Gains (Pr 00.007 {03.010}, Pr 00.008 {03.011}, Pr 00.009 {03.012})

The speed loop gains control the response of the speed controller to a change in speed demand. The speed controller includes proportional (Kp) and integral (Ki) feed forward terms, and a differential (Kd) feedback term. The drive holds two sets of these gains and either set may be selected for use by the speed controller with Pr 03.016. If Pr 03.016 = 0, gains Kp1, Ki1 and Kd1 (Pr 00.007 to Pr 00.009) are used, and if Pr 03.016 = 1, gains Kp2, Ki2 and Kd2 (Pr 03.013 to Pr 03.015) are used. Pr 03.016 may be changed when the drive is enabled or disabled. If the load is predominantly a constant inertia and constant torque, the drive can calculate the required Kp and Ki gains to give a required compliance angle or bandwidth dependant on the setting of Pr 03.017.

**NOTE: In sensorless mode, the speed controller bandwidth may need to be limited to 10 Hz or less for stable operation.**

#### Speed Controller Proportional Gain (Kp), Pr 00.007 {03.010} and Pr 03.013

If the proportional gain has a value and the integral gain is set to zero the controller will only have a proportional term, and there must be a speed error to produce a torque reference. Therefore as the motor load increases there will be a difference between the reference and actual speeds. This effect, called regulation, depends on the level of the proportional gain, the higher the gain the smaller the speed error for a given load. If the proportional gain is too high either the acoustic noise produced by speed feedback quantization becomes unacceptable, or the stability limit is reached.

#### Speed Controller Integral Gain (Ki), Pr 00.008 {03.011} and Pr 03.014

The integral gain is provided to prevent speed regulation. The error is accumulated over a period of time and used to produce the necessary torque demand without any speed error. Increasing the integral gain reduces the time taken for the speed to reach the correct level and increases the stiffness of the system, i.e. it reduces the positional displacement produced by applying a load torque to the motor. Unfortunately increasing the integral gain also reduces the system damping giving overshoot after a transient. For a given integral gain the damping can be improved by increasing the proportional gain. A compromise must be reached where the system response, stiffness and damping are all adequate for the application. For RFC-S Sensorless mode, it is unlikely that the integral gain can be increased much above 0.50.

#### Differential Gain (Kd), Pr 00.009 {03.012} and Pr 03.015

The differential gain is provided in the feedback of the speed controller to give additional damping. The differential term is implemented in a way that does not introduce excessive noise normally associated with this type of function. Increasing the differential term reduces the overshoot produced by under-damping, however, for most applications the proportional and integral gains alone are sufficient.

There are six methods of tuning the speed loop gains dependant on the setting of Pr 03.017:

- Pr 03.017 = 0, User set-up.  
This involves the connecting of an oscilloscope to analog output 1 to monitor the speed feedback.  
Give the drive a step change in speed reference and monitor the response of the drive on the oscilloscope.  
The proportional gain (Kp) should be set up initially. The value should be increased up to the point where the speed overshoots and then reduced slightly.  
The integral gain (Ki) should then be increased up to the point where the speed becomes unstable and then reduced slightly.  
It may now be possible to increase the proportional gain to a higher value and the process should be repeated until the system response matches the ideal response as shown.  
The diagram shows the effect of incorrect P and I gain settings as well as the ideal response.
- Pr 03.017 = 1, Bandwidth set-up  
If bandwidth based set-up is required, the drive can calculate Kp and Ki if the following parameters are set up correctly:  
Pr 03.020 - Required bandwidth,  
Pr 03.021 - Required damping factor,  
Pr 03.018 - Motor and load inertia.  
The drive can be made to measure the motor and load inertia by performing an inertia measurement autotune (see Autotune Pr 00.040, earlier in this table).
- Pr 03.017 = 2, Compliance angle set-up  
If compliance angle based set-up is required, the drive can calculate Kp and Ki if the following parameters are set up correctly:  
Pr 03.019 - Required compliance angle,  
Pr 03.021 - Required damping factor,  
Pr 03.018 - Motor and load inertia  
The drive can be made to measure the motor and load inertia by performing an inertia measurement autotune (see Autotune Pr 00.040, earlier in this table).
- Pr 03.017 = 3, Kp gains times 16  
If Speed Controller Set-up Method (03.017) = 3 the selected proportional gain used by the drive is multiplied by 16.

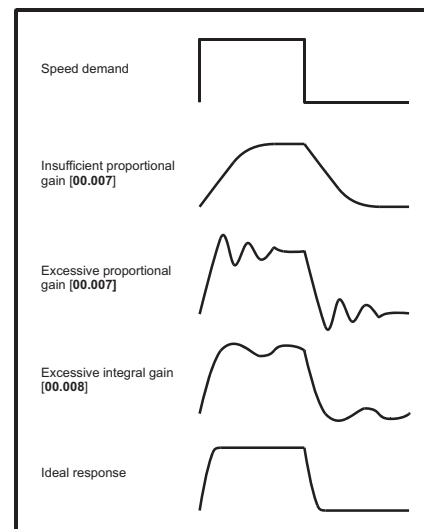

#### 5. Pr 03.017 = 4 - 6

If Speed Controller Set-up Method (03.017) is set to a value from 4 to 6 the Speed Controller Proportional Gain Kp1 Pr 00.007 {03.010} and Speed Controller Integral Gain Ki1 Pr 00.008 {03.011} are automatically set up to give the bandwidths given in the table below and a damping factor of unity. These settings give low, standard or high performance.

Pr 03.017	Performance	Bandwidth
4	Low	5 Hz
5	Standard	25 Hz
6	High	100 Hz

#### 6. Pr 03.017 = 7

If Speed Controller Set-up Method (03.017) = 7 then Speed Controller Proportional Gain Kp1 Pr 00.007 {03.010}, Speed Controller Integral Gain Ki1 Pr 00.008 {03.011} and Speed Controller Differential Feedback Gain Kd1 Pr 00.009 {03.012} are set up to give a closed-loop speed controller response that approximates to a first order system with a transfer function of  $1 / (s\tau + 1)$ , where  $\tau = 1/\omega bw$  and  $\omega bw = 2\pi \times \text{Bandwidth}$  (03.020). In this case the damping factor is meaningless, and Damping Factor (03.021) and Compliance Angle (03.019) have no effect.

## 7.2 Maximum motor rated current

The maximum motor rated current allowed by the drive is greater than the *Maximum Heavy Duty Current Rating* Pr 00.032 {11.032}. The ratio between the Normal Duty rating (11.060) and the *Maximum Heavy Duty Current Rating* Pr 00.032 {11.032} varies between drive sizes. The values for the Normal and Heavy Duty rating can be found in the appropriate *Power Installation Guide* for the drive. If the motor *Rated Current* (00.046) is set above the *Maximum Heavy Duty Current Rating* Pr 00.032 {11.032}, the current limits and the motor thermal protection scheme are modified (see section 7.3 and section 7.4 for more information).

## 7.3 Current limits

The default setting for the current limit parameters are:

- 165 % x motor rated torque producing current for open loop mode
- 175 % x motor rated torque producing current for RFC-A and RFC-S modes

There are three parameters which control the current limits:

- Motoring current limit: power flowing from the drive to the motor
- Regen current limit: power flowing from the motor to the drive
- Symmetrical current limit: current limit for both motoring and regen operation

The lowest of either the motoring and regen current limit, or the symmetrical current limit applies.

The maximum setting of these parameters depends on the values of motor rated current, drive rated current and the power factor.

Increasing the motor rated current (Pr 00.046 {05.007}) above the Heavy Duty rating (default value), will automatically reduce the current limits in Pr 04.005 to Pr 04.007. If the motor rated current is then set to or below the Heavy Duty rating, the current limits will be left at their reduced values.

The drive can be oversized to permit a higher current limit setting to provide higher accelerating torque as required up to a maximum of 1000 %.

## 7.4 Motor thermal protection

A dual time constant thermal model is provided to estimate the motor temperature as a percentage of its maximum allowed temperature.

The motor thermal protection is modelled using losses in the motor. The losses in the motor are calculated as a percentage value, so that under these conditions the *Motor Protection Accumulator* (04.019) would eventually reach 100 %.

Percentage losses = 100 % x [Load related losses + Iron losses]

Where:

$$\text{Load related losses} = (1 - K_{fe}) \times (I / (K_1 \times I_{\text{Rated}}))^2$$

$$\text{Iron losses} = K_{fe} \times (w / w_{\text{Rated}})^{1.6}$$

Where:

$$I = \text{Current Magnitude Pr 00.012 \{04.001\}}$$

$$I_{\text{Rated}} = \text{Rated Current Pr 00.046 \{05.007\}}$$

$$K_{fe} = \text{Rated Iron Losses As Percentage Of Losses (04.039) / 100 \%}$$

The *Motor Protection Accumulator* (04.019) is given by:

$$\text{Pr 04.019} = \text{Percentage Losses} \times [(1 - K_2) (1 - e^{-t/\tau_1}) + K_2 (1 - e^{-t/\tau_2})]$$

Where:

$$T = \text{Motor Protection Accumulator (04.019)}$$

$$K_2 = \text{Motor Thermal Time Constant 2 Scaling (04.038) / 100 \%}$$

$$\tau_1 = \text{Motor Thermal Time Constant 1 Pr 00.053 \{04.015\}}$$

$$\tau_2 = \text{Motor Thermal Time Constant 2 (04.037)}$$

$$K_1 = \text{Varies, see below}$$

If *Rated Current* Pr 00.046 {05.007} ≤ *Maximum Heavy Duty Current Rating* Pr 00.032 {11.032}

Figure 7-1 Motor thermal protection (Heavy Duty)

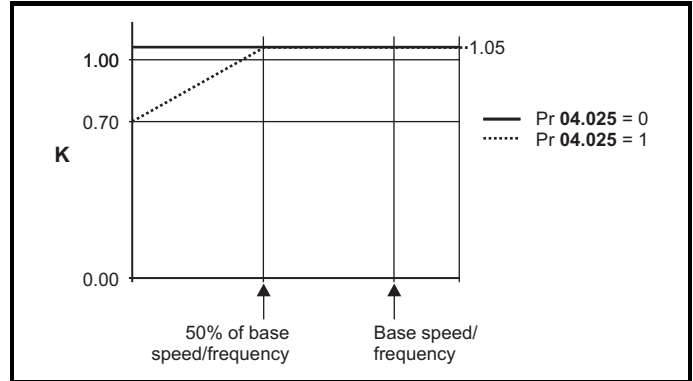

If Pr 04.025 is 0 the characteristic is for a motor which can operate at rated current over the whole speed range. Induction motors with this type of characteristic normally have forced cooling. If Pr 04.025 is 1 the characteristic is intended for motors where the cooling effect of motor fan reduces with reduced motor speed below 50 % of base speed/frequency. The maximum value for K1 is 1.05, so that above the knee of the characteristics the motor can operate continuously up to 105 % current.

Figure 7-2 Motor thermal protection (Normal Duty)

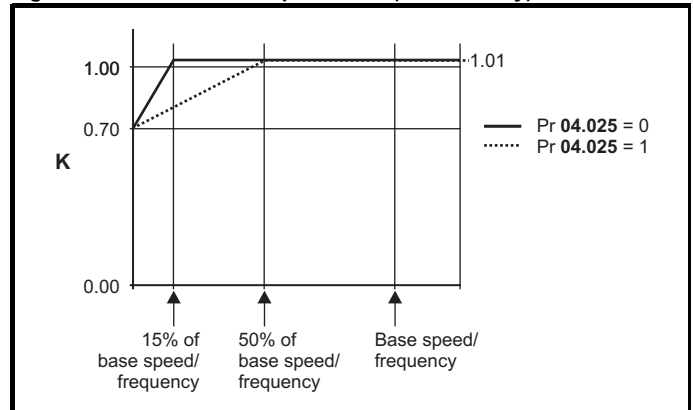

Both settings of Pr 04.025 are intended for motors where the cooling effect of the motor fan reduces with reduced motor speed, but with different speeds below which the cooling effect is reduced. If Pr 04.025 is 0 the characteristic is intended for motors where the cooling effect reduces with motor speed below 15 % of base speed/frequency. If Pr 04.025 is 1 the characteristic is intended for motors where the cooling effect reduces with motor speed below 50 % of base speed/frequency. The maximum value for K1 is 1.01, so that above the knee of the characteristics the motor can operate continuously up to 101 % current. When the estimated temperature in Pr 04.019 reaches 100 % the drive takes some action depending on the setting of Pr 04.016. If Pr 04.016 is 0, the drive trips when Pr 04.019 reaches 100 %. If Pr 04.016 is 1, the current limit is reduced to (K - 0.05) x 100 % when Pr 04.019 reaches 100 %.

The current limit is set back to the user defined level when Pr 04.019 falls below 95 %. The thermal model temperature accumulator accumulates the temperature of the motor while the drive remains powered-up. By default, the accumulator is set to the power down value at power up. If the rated current defined by Pr 00.046 {05.007} is altered, the accumulator is reset to zero.

The default setting of the thermal time constant Pr 00.053 {04.015} is 89 s which is equivalent to an overload of 150 % for 60 s from cold.

## 7.5 Switching frequency

The default switching frequency is 3 kHz, however this can be increased up to a maximum of 16 kHz by Pr **00.041** {**05.018**} (dependent on drive size). The available switching frequencies are shown below.

**Table 7-1 Available switching frequencies**

Drive size	Model	2 kHz	3 kHz	4 kHz	6 kHz	8 kHz	12 kHz	16 kHz	
3	All								
4									
5									
6		✓	✓	✓	✓	✓	✓	✓	
7									
8									
9									
10									
11		400V	✓	✓	✓	✓	✓		
11		575 and 690V	✓	✓	✓				

If switching frequency is increased from 3 kHz the following apply:

- Increased heat loss in the drive, which means that derating to the output current must be applied. See the derating tables for switching frequency and ambient temperature in the *Power Installation Guide*.
- Reduced heating of the motor - due to improved output waveform quality.
- Reduced acoustic noise generated by the motor.
- Increased sample rate on the speed and current controllers. A trade off must be made between motor heating, drive heating and the demands of the application with respect to the sample time required.

**Table 7-2 Sample rates for various control tasks at each switching frequency**

	3, 6, 12 kHz	2, 4, 8, 16 kHz	Open loop	RFC-A RFC-S
Level 1	3 kHz = 167 μs 6 kHz = 83 μs 12 kHz = 83 μs	2 kHz = 250 μs 4 kHz = 125 μs 8 kHz = 62.5 μs 16 kHz = 62.5 μs	Peak limit	Current controllers
Level 2	250 μs	2 kHz - 500 μs 4 kHz - 250 μs 8 kHz - 125 μs 16 kHz - 125 μs	Current limit and ramps	Speed controller and ramps
Level 3	1 ms		Voltage controller	
Level 4	4 ms		Time critical user interface	
Background			Non-time critical user interface	

## 7.6 High speed operation

### 7.6.1 Field weakening (constant power) operation

(Open loop and RFC-A mode only)

The drive can be used to run an induction machine above synchronous speed into the constant power region. The speed continues to increase and the available shaft torque reduces. The characteristics below show the torque and output voltage characteristics as the speed is increased above the rated value.

**Figure 7-3 Torque and rated voltage against speed**

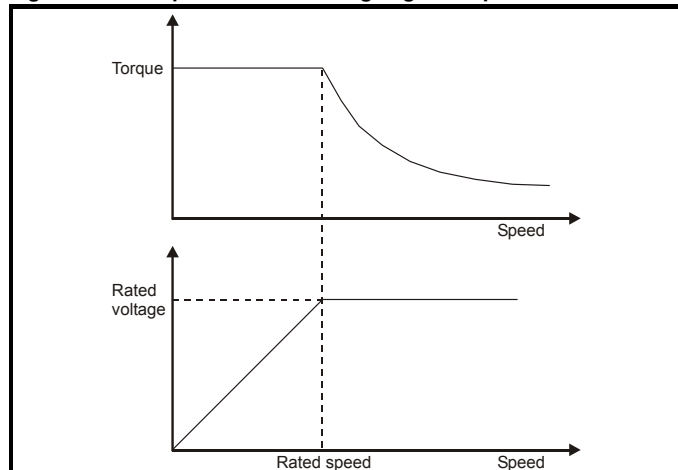

Care must be taken to ensure the torque available above base speed is sufficient for the application to run satisfactorily.

The saturation breakpoint parameters (Pr **05.029**, Pr **05.030**, Pr **05.062** and Pr **05.063**) found during the autotune in RFC-A mode ensure the magnetizing current is reduced in the correct proportion for the specific motor. (In open loop mode the magnetizing current is not actively controlled).

### 7.6.2 Permanent magnet motor high speed operation

High speed servo mode is enabled by setting Pr **05.022** = 1. Care must be taken when using this mode with permanent magnet motor to avoid damaging the drive. The voltage produced by the permanent magnet motor magnets is proportional to speed. For high speed operation the drive must apply currents to the motor to counter-act the flux produced by the magnets. It is possible to operate the motor at very high speeds that would give a very high motor terminal voltage, but this voltage is prevented by the action of the drive.

If however, the drive is disabled (or tripped) when the motor voltages would be higher than the rating of the drive without the currents to counter-act the flux from the magnets, it is possible to damage the drive. If high speed mode is enabled the motor speed must be limited to the levels given in the table below unless an additional hardware protection system is used to limit the voltages applied to the drive output terminals to a safe level.

Drive voltage rating	Maximum motor speed (rpm)	Maximum safe line to line voltage at the motor terminals (V rms)
200	$400 \times 1000 / (K_e \times \sqrt{2})$	$400 / \sqrt{2}$
400	$800 \times 1000 / (K_e \times \sqrt{2})$	$800 / \sqrt{2}$
575	$955 \times 1000 / (K_e \times \sqrt{2})$	$955 / \sqrt{2}$
690	$1145 \times 1000 / (K_e \times \sqrt{2})$	$1145 / \sqrt{2}$

$K_e$  is the ratio between r.m.s. line to line voltage produced by the motor and the speed in V/1000 rpm. Care must also be taken not to demagnetize the motor. The motor manufacturer should always be consulted before using this mode.

By default, high speed operation is disabled (Pr **05.022** = 0).

It is also possible to enable high speed operation, and allow the drive to automatically limit the motor speed to the levels specified in the tables and generate an Overspeed.1 trip if the levels are exceeded (Pr **05.022** = -1)

### 7.6.3 Maximum speed / frequency

In all operating modes (Open loop, RFC-A and RFC-S) the maximum output frequency is limited to 550 Hz. However, in RFC-S mode the speed is also limited by the voltage constant ( $K_e$ ) of the motor.  $K_e$  is a specific constant for the servo motor being used. It can normally be found on the motor data sheet in V/k rpm (volts per 1,000 rpm).

### 7.6.4 Switching frequency

With a default switching frequency of 3 kHz the maximum output frequency should be limited to 250 Hz. Ideally a minimum ratio of 12:1 should be maintained between the output frequency and the switching frequency. This ensures the number of switchings per cycle is sufficient to ensure the output waveform quality is maintained at a minimum level. If this is not possible, quasi-square switching should be enabled (Pr **05.020** =1). The output waveform will be quasi square above base speed ensuring a symmetrical output waveform, which results in a better quality output than would otherwise result.

### 7.6.5 Quasi-Square wave (open-loop only)

The maximum output voltage level of the drive is normally limited to an equivalent of the drive input voltage minus voltage drops within the drive (the drive will also retain a few percent of the voltage in order to maintain current control). If the motor rated voltage is set at the same level as the supply voltage, some pulse deletion will occur as the drive output voltage approaches the rated voltage level. If Pr **05.020** (Quasi-square wave enable) is set to 1 the modulator will allow over modulation, so that as the output frequency increases beyond the rated frequency the voltage continues to increase above the rated voltage. The modulation depth will increase beyond unity; first producing trapezoidal and then quasi-square waveforms.

This can be used for example:

- To obtain high output frequencies with a low switching frequency which would not be possible with space vector modulation limited to unity modulation depth,

or

- In order to maintain a higher output voltage with a low supply voltage.

The disadvantage is that the machine current will be distorted as the modulation depth increases above unity, and will contain a significant amount of low order odd harmonics of the fundamental output frequency. The additional low order harmonics cause increased losses and heating in the motor.



### 7.7.3 MODBUS registers

The MODBUS register address range is 16 bit (65536 registers) which at the protocol level is represented by indexes 0 through 65535.

#### PLC registers

Modicon PLCs typically define 4 register 'files' each containing 65536 registers. Traditionally, the registers are referenced 1 through 65536 rather than 0 through 65535. The register address is therefore decremented on the master device before passing to the protocol.

File type	Description
1	Read only bits ("coil")
2	Read / write bits ("coil")
3	Read only 16bit register
4	Read / write 16bit register

The register file type code is NOT transmitted by MODBUS and all register files can be considered to map onto a single register address space. However, specific function codes are defined in MODBUS to support access to the "coil" registers. All standard CT drive parameters are mapped to register file '4' and the coil function codes are not required.

#### CT parameter mapping

The Modbus register address is 16 bits in size, of which the upper two bits are used for data type selection leaving 14 bits to represent the parameter address, taking into account the slave increments the address value by 1, this results in a theoretical maximum parameter address of 163.84 (limited to 162.99 in software) when the default standard addressing mode (see *Serial Mode Pr 00.035 {11.024}*) is used.

To access a parameter number above 99 in any drive menu then the modified addressing mode must be used (see *Serial Mode Pr 00.035 {11.024}*), this will allow access to parameter numbers up to 255 but also limit the maximum menu number to 63.

The Modbus slave device increments the register address by 1 before processing the command, this effectively prevents access to parameter Pr 00.000 in the drive or option module.

The table below shows how the start register address is calculated for both addressing modes.

Parameter	Addressing mode	Protocol register			
0.mm.ppp	Standard	mm x 100 + ppp - 1			
	Modified	mm x 256 + ppp - 1			
<b>Examples</b>					
		<b>16-bit</b>		<b>32-bit</b>	
		<b>Decimal</b>	<b>Hex (0x)</b>	<b>Decimal</b>	<b>Hex (0x)</b>
0.01.021	Standard	120	00 78	16504	40 78
	Modified	276	01 14	16660	41 14
0.01.000	Standard	99	00 63	16483	40 63
	Modified	255	00 FF	16639	40 FF
0.03.161	Standard	N/A	N/A	N/A	N/A
	Modified	928	03 A0	17312	43 A0

#### Data types

The MODBUS protocol specification defines registers as 16 bit signed integers. All CT devices support this data size. Refer to the section 7.7.7 *Extended data types* on page 95 for detail on accessing 32 bit register data.

#### 7.7.4 Data consistency

All CT devices support a minimum data consistency of one parameter (16 bit or 32 bit data). Some devices support consistency for a complete multiple register transaction.

#### 7.7.5 Data encoding

MODBUS RTU uses a 'big-endian' representation for addresses and data items (except the CRC, which is 'little-endian'). This means that when a numerical quantity larger than a single byte is transmitted, the MOST significant byte is sent first. So for example

16 - bits    0x1234        would be    0x12    0x34

32 - bits    0x12345678    would be    0x12    0x34    0x56    0x78

#### 7.7.6 Function codes

The function code determines the context and format of the message data. Bit 7 of the function code is used in the slave response to indicate an exception.

The following function codes are supported:

Code	Description
3	Read multiple 16 bit registers
6	Write single register
16	Write multiple 16 bit registers
23	Read and write multiple 16 bit registers

### FC03 Read multiple

Read a contiguous array of registers. The slave imposes an upper limit on the number of registers, which can be read. If this is exceeded the slave will issue an exception code 2.

**Table 7-3 Master request**

Byte	Description
0	Slave destination node address 1 through 247, 0 is global
1	Function code 0x03
2	Start register address MSB
3	Start register address LSB
4	Number of 16 bit registers MSB
5	Number of 16 bit registers LSB
6	CRC LSB
7	CRC MSB

**Table 7-4 Slave response**

Byte	Description
0	Slave source node address
1	Function code 0x03
2	Length of register data in read block (in bytes)
3	Register data 0 MSB
4	Register data 0 LSB
3+byte count	CRC LSB
4+byte count	CRC MSB

### FC06 Write single register

Writes a value to a single 16 bit register. The normal response is an echo of the request, returned after the register contents have been written. The register address can correspond to a 32 bit parameter but only 16 bits of data can be sent.

**Table 7-5 Master request**

Byte	Description
0	Slave node address 1 through 247, 0 is global
1	Function code 0x06
2	Register address MSB
3	Register address LSB
4	Register data MSB
5	Register data LSB
6	CRC LSB
7	CRC MSB

**Table 7-6 Slave response**

Byte	Description
0	Slave source node address
1	Function code 0x06
2	Register address MSB
3	Register address LSB
4	Register data MSB
5	Register data LSB
6	CRC LSB
7	CRC MSB

### FC16 Write multiple

Writes a contiguous array of registers. The slave imposes an upper limit on the number of registers which can be written. If this is exceeded the slave will discard the request and the master will time out.

**Table 7-7 Master request**

Byte	Description
0	Slave node address 1 through 247, 0 is global
1	Function code 0x10
2	Start register address MSB
3	Start register address LSB
4	Number of 16 bit registers MSB
5	Number of 16 bit registers LSB
6	Length of register data to write (in bytes)
7	Register data 0 MSB
8	Register data 0 LSB
7+byte count	CRC LSB
8+byte count	CRC MSB

**Table 7-8 Slave response**

Byte	Description
0	Slave source node address
1	Function code 0x10
2	Start register address MSB
3	Start register address LSB
4	Number of 16 bit registers written MSB
5	Number of 16 bit registers written LSB
6	CRC LSB
7	CRC MSB

### FC23 Read/Write multiple

Writes and reads two contiguous arrays of registers. The slave imposes an upper limit on the number of registers which can be written. If this is exceeded the slave will discard the request and the master will time out.

**Table 7-9 Master request**

Byte	Description
0	Slave node address 1 through 247, 0 is global
1	Function code 0x17
2	Start register address to read MSB
3	Start register address to read LSB
4	Number of 16 bit registers to read MSB
5	Number of 16 bit registers to read LSB
6	Start register address to write MSB
7	Start register address to write LSB
8	Number of 16 bit registers to write MSB
9	Number of 16 bit registers to write LSB
10	Length of register data to write (in bytes)
11	Register data 0 MSB
12	Register data 0 LSB
11+byte count	CRC LSB
12+byte count	CRC MSB

**Table 7-10 Slave response**

Byte	Description
0	Slave source node address
1	Function code 0x17
2	Length of register data in read block (in bytes)
3	Register data 0 MSB
4	Register data 0 LSB
3+byte count	CRC LSB
4+byte count	CRC MSB

### 7.7.7 Extended data types

Standard MODBUS registers are 16bit and the standard mapping maps a single #X.Y parameter to a single MODBUS register. To support 32 bit data types (integer and float) the MODBUS multiple read and write services are used to transfer a contiguous array of 16bit registers.

Slave devices typically contain a mixed set of 16 bit and 32 bit registers. To permit the master to select the desired 16 bit or 32 bit access the top two bits of the register address are used to indicate the selected data type.

**NOTE**

The selection is applied for the whole block access.

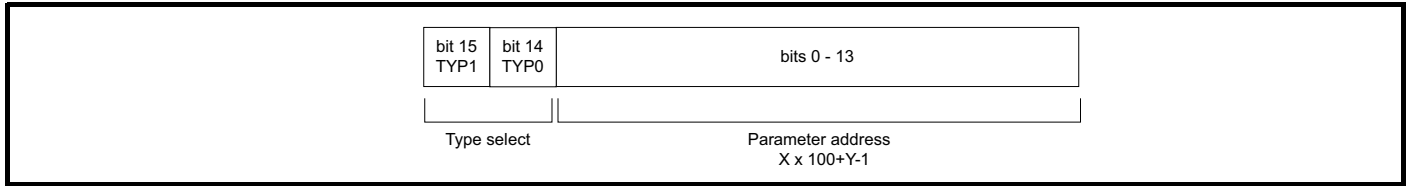

The 2bit type field selects the data type according to the table below:

Type field bits 15-14	Selected data type	Comments
00	INT16	backward compatible
01	INT32	
10	Float32	IEEE754 standard Not supported on all slaves
11	Reserved	

If a 32 bit data type is selected then the slave uses two consecutive 16 bit MODBUS registers (in 'big endian'). The master must also set the correct 'number of 16 bit registers'.

Example, read Pr **20.021** through Pr **20.024** as 32 bit parameters using FC03 from node 8:

**Table 7-11 Master request**

Byte	Value	Description
0	0x08	Slave destination node address
1	0x03	FC03 multiple read
2	0x47	Start register address Pr <b>20.021</b>
3	0xE4	(16384 + 2021 - 1) = 18404 = 0x47E4
4	0x00	Number of 16bit registers to read
5	0x08	Pr <b>20.021</b> through Pr <b>20.024</b> is 4x32 bit registers = 8x16 bit registers
6	CRC LSB	
7	CRC MSB	

**Table 7-12 Slave response**

Byte	Value	Description
0	0x08	Slave destination node address
1	0x03	FC03 multiple read
2	0x10	Length of data (bytes) = 4x32 bit registers = 16 bytes
3-6		Pr <b>20.021</b> data
7-10		Pr <b>20.022</b> data
11-14		Pr <b>20.023</b> data
15-18		Pr <b>20.024</b> data
19	CRC LSB	
20	CRC MSB	

**Reads when actual parameter type is different from selected**

The slave will send the least significant word of a 32 bit parameter if that parameter is read as part of a 16 bit access.

The slave will sign extend the least significant word if a 16 bit parameter is accessed as a 32 bit parameter. The number of 16 bit registers must be even during a 32 bit access.

Example, If Pr **01.028** is a 32 bit parameter with a value of 0x12345678, Pr **01.029** is a signed 16 bit parameter with a value of 0xABCD, and Pr **01.030** is a signed 16 bit parameter with a value of 0x0123.

Read	Start register address	Number of 16 bit registers	Response	Comments
Pr 01.028	127	1	0x5678	Standard 16 bit access to a 32 bit register will return low 16 bit word of truncated data
Pr 01.028	16511*	2	0x12345678	Full 32 bit access
Pr 01.028	16511*	1	Exception 2	Number of words must be even for 32 bit access
Pr 01.029	128	1	0xABCD	Standard 16 bit access to a 32 bit register will return low 16 bit word of data
Pr 01.029	16512*	2	0xFFFFABCD	32 bit access to a 16 bit register will return 32 bit sign extended data
Pr 01.030	16513*	2	0x00000123	32 bit access to a 16 bit register will return 32 bit sign extended data
Pr 01.028 to Pr 01.029	127	2	0x5678, 0xABCD	Standard 16 bit access to a 32 bit register will return low 16 bit word of truncated data
Pr 01.028 to Pr 01.029	16511*	4	0x12345678, 0xFFFFABCD	Full 32 bit access

\* Bit 14 is set to allow 32 bit access.

#### Writes when actual parameter type is different from selected

The slave will allow writing a 32 bit value to a 16 bit parameter as long as the 32 bit value is within the normal range of the 16 bit parameter.

The slave will allow a 16 bit write to a 32 bit parameter. The slave will sign extend the written value, therefore the effective range of this type of write will be -32768 to +32767.

Examples, if Pr 01.028 has a range of  $\pm 100000$ , and Pr 01.029 has a range of  $\pm 10000$ .

Write	Start register address	Number of 16bit registers	Data	Comments
Pr 01.028	127	1	0x1234	Standard 16 bit write to a 32bit register. Value written = 0x00001234
Pr 01.028	127	1	0xABCD	Standard 16 bit write to a 32bit register. Value written = 0xFFFFABCD
Pr 01.028	16511	2	0x00001234	Value written = 0x00001234
Pr 01.029	128	1	0x0123	Value written = 0x0123
Pr 01.029	16512	2	0x00000123	Value written = 0x00000123

\* Bit 14 is set to allow 32 bit access

#### 7.7.8 Exceptions

The slave will respond with an exception response if an error is detected in the master request. If a message is corrupted and the frame is not received or the CRC fails then the slave will not issue an exception. In this case the master device will time out. If a write multiple (FC16 or FC23) request exceeds the slave maximum buffer size then the slave will discard the message. No exception will be transmitted in this case and the master will time out.

#### Exception message format

The slave exception message has the following format.

Byte	Description
0	Slave source node address
1	Original function code with bit 7 set
2	Exception code
3	CRC LSB
4	CRC MSB

#### Exception codes

The following exception codes are supported.

Code	Description
1	Function code not supported
2	Register address out of range, or request to read too many registers

#### Parameter over range during block write FC16

The slave processes the write block in the order the data is received. If a write fails due to an out of range value then the write block is terminated. However, the slave does not raise an exception response, rather the error condition is signalled to the master by the number of successful writes field in the response.

#### Parameter over range during block read/write FC23

There will be no indication that there has been a value out of range during a FC23 access.

### 7.7.9 CRC

The CRC is a 16 bit cyclic redundancy check using the standard CRC-16 polynomial  $x^{16} + x^{15} + x^2 + 1$ . The 16 bit CRC is appended to the message and transmitted LSB first.

The CRC is calculated on ALL the bytes in the frame.

### 7.7.10 Device compatibility parameters

All devices have the following compatibility parameters defined:

Parameter	Description
Device ID	Unique device identification code
Minimum slave response time	The minimum delay between the end of a message from the master and the time at which the master is ready to receive a response from the slave.
Maximum slave response time	When global addressing, the master must wait for this time before issuing a new message. In a network of devices, the slowest time must be used
Baud rate	Baud rate used by Modbus RTU
32 bit float data type supported	If this data type is not supported then an over range error will be raised if this data type is used
Maximum buffer size	Determines the maximum block size.

# 8 NV Media Card Operation

## 8.1 Introduction

The Non-Volatile Media Card feature enables simple configuration of parameters, parameter back-up, storing / reading PLC programs and drive copying using a SMARTCARD or SD card storing / reading PLC programs. The drive offers backward compatibility for a Unidrive SP SMARTCARD.

The NV Media Card can be used for:

- Parameter copying between drives
- Saving drive parameter sets
- Saving an onboard user program

The NV Media Card is located at the top of the module under the drive display (if installed) on the left-hand side.

Ensure the NV Media Card is inserted with the contacts facing the left-hand side of the drive.

The drive only communicates with the NV Media Card when commanded to read or write, meaning the card may be "hot swapped".

The Unidrive M is not able to read any other type of Unidrive SP data block on the card. Although it is possible to transfer difference from default data blocks from a Unidrive SP into the Unidrive M, the following should be noted:

1. If a parameter from the source drive does not exist in the target drive then no data is transferred for that parameter.
2. If the data for the parameter in the target drive is out of range then the data is limited to the range of the target parameter.
3. If the target drive has a different rating to the source drive then the normal rules for this type of transfer apply.

**Figure 8-2 Basic NV Media Card operation**

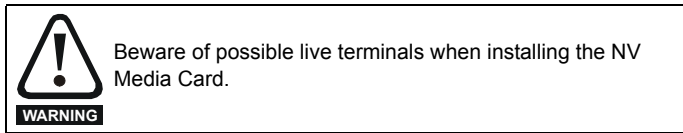

**Figure 8-1 Installation of the NV Media Card**

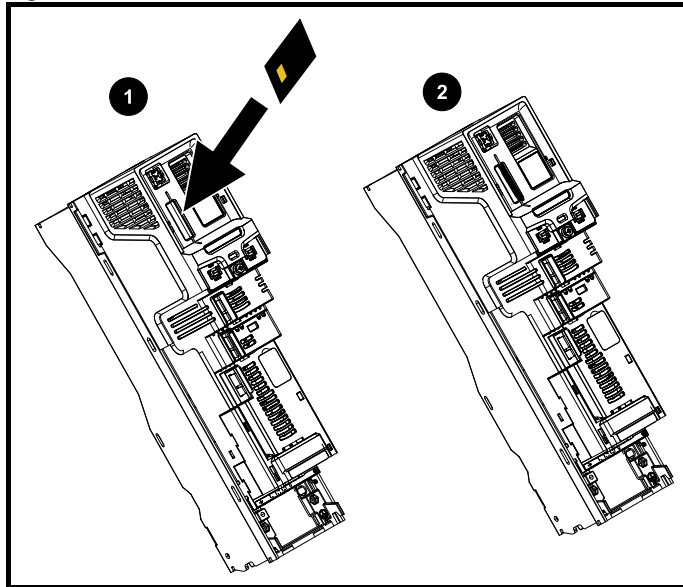

1. Installing the NV Media Card
2. NV Media Card installed

NV Media Card	Part number
SD Card Adaptor (memory card not included)	3130-1212
8 kB SMARTCARD	2214-4246
64 kB SMARTCARD	2214-1006

## 8.2 NV Media Card support

The NV Media Card can be used to store drive parameter sets and / or PLC programs set from the Unidrive M in data blocks 001 to 499 on the card.

The Unidrive M is compatible with a Unidrive SP SMARTCARD and is able to read and translate the Unidrive SP parameter set into a compatible parameter set for Unidrive M. This is only possible if the Unidrive SP parameter set was transferred to the SMARTCARD using the difference from defaults transfer method (i.e. 4yyy transfer).

Drive reads all parameters from the NV Media Card

**Pr 00.030 = Read +**

Programs all drive parameters to the NV Media Card

**NOTE** Overwrites any data already in data block 1

**Pr 00.030 = Program +**

Drive automatically writes to the NV Media Card when a parameter save is performed

Auto Save

**Pr 00.030 = Auto +**

Drive boots from the NV Media Card on power up and automatically writes to the NV Media Card when a parameter save is performed

Auto Save

**Pr 00.030 = Boot +**

The whole card may be protected from writing or erasing by setting the read-only flag as detailed in section 8.3.9 9888 / 9777 - *Setting and clearing the NV Media Card read only flag* on page 101.

The card should not be removed during data transfer, as the drive will produce a trip. If this occurs then either the transfer should be re-attempted or in the case of a card to drive transfer, default parameters should be loaded.

## 8.3 Transferring data

Data transfer, erasing and protecting the information is performed by entering a code in Pr **mm.000** and then resetting the drive as shown in Table 8-1.

**Table 8-1 SMARTCARD and SD card codes**

Code	Operation	SMARTCARD	SD card
2001	Transfer the drive parameters to parameter file 001 and sets the block as bootable. This will include the parameters from attached option modules.	✓	✓
4yyy	Transfer the drive parameters to parameter file yyy. This will include the parameters from attached option modules.	✓	✓
5yyy	Transfer the onboard user program to onboard user program file yyy.	✓	✓
6yyy	Load the drive parameters from parameter file yyy or the onboard user program from onboard user program file yyy.	✓	✓
7yyy	Erase file yyy.	✓	✓
8yyy	Compare the data in the drive with file yyy. If the files are the same then <i>Pr mm.000 (mm.000)</i> is simply reset to 0 when the compare is complete. If the files are different a 'Card Compare' trip is initiated. All other NV media card trips also apply.	✓	✓
9555	Clear the warning suppression flag	✓	✓
9666	Set the warning suppression flag	✓	✓
9777	Clear the read-only flag	✓	✓
9888	Set the read-only flag	✓	✓
9999	Erase and format the NV media card	✓	

Where yyy indicates the block number 001 to 999.

### NOTE

If the read only flag is set then only codes 6yyy or 9777 are effective.

### 8.3.1 Writing to the NV Media Card

#### 4yyy - Writes defaults differences to the NV Media Card

The data block only contains the parameter differences from the last time default settings were loaded.

All parameters except those with the NC (Not copied) coding bit set are transferred to the NV Media Card. In addition to these parameters all menu 20 parameters (except Pr **20.000**), can be transferred to the NV Media Card.

#### Writing a parameter set to the NV Media Card (Pr 11.042 = Program (2))

Setting Pr **11.042** to Program (2) and resetting the drive will save the parameters to the NV Media Card, i.e. this is equivalent to writing 4001 to Pr **mm.000**. All NV Media Card trips apply except 'Card Change'. If the data block already exists it is automatically overwritten. When the action is complete this parameter is automatically reset to None (0).

### 8.3.2 Reading from the NV Media Card

#### 6yyy - Reading from NV Media Card

When the data is transferred back to the drive, using 6yyy in Pr **mm.000**, it is transferred to the drive RAM and the EEPROM. A parameter save is not required to retain the data after-power down. Set up data for any option modules installed stored on the card are transferred to the drive. If the option modules installed are different between source and destination drives, the menus for the option module slots where the option module categories are different are not updated from the card and will contain their default values after the copying action. The drive will produce a 'Card Option' trip if the option module installed to the source and the destination drives are different or are in different slots. If the data is being transferred to the drive with different voltage or current rating a 'Card Rating' trip will occur.

The following drive rating dependant parameters (RA coding bit set) will not be transferred to the destination drive by a NV Media Card when the voltage rating of the destination drive is different from the source drive and the file is a parameter file.

However, drive rating dependent parameters will be transferred if only the current rating is different. If drive rating dependant parameters are not transferred to the destination drive they will contain their default values.

Pr **02.008** *Standard Ramp Voltage*

Pr **04.005** to Pr **04.007** and Pr **21.027** to Pr **21.029** *Motoring Current Limits*

Pr **04.024**, *User Current Maximum Scaling*

Pr **05.007**, Pr **21.007** *Rated Current*

Pr **05.009**, Pr **21.009** *Rated Voltage*

Pr **05.010**, Pr **21.010** *Rated Power Factor*

Pr **05.017**, Pr **21.012** *Stator Resistance*

Pr **05.018** *Maximum Switching Frequency*

Pr **05.024**, Pr **21.014** *Transient Inductance*

Pr **05.025**, Pr **21.024** *Stator Inductance*

Pr **06.006** *Injection Braking Level*

Pr **06.048** *Supply Loss Detection Level*

Pr **06.065** *Standard Under Voltage Threshold*

Pr **06.066** *Low Under Voltage Threshold*

### Reading a parameter set from the NV Media Card (Pr 11.042 = Read (1))

Setting Pr 11.042 to Read (1) and resetting the drive will transfer the parameters from the card into the drive parameter set and the drive EEPROM, i.e. this is equivalent to writing 6001 to Pr mm.000.

All NV Media Card trips apply. Once the parameters are successfully copied this parameter is automatically reset to None (0). Parameters are saved to the drive EEPROM after this action is complete.

#### 8.3.3 Auto saving parameter changes (Pr 11.042 = Auto (3))

This setting causes the drive to automatically save any changes made to menu 0 parameters on the drive to the NV Media Card. The latest menu 0 parameter set in the drive is therefore always backed up on the NV Media Card. Changing Pr 11.042 to Auto (3) and resetting the drive will immediately save the complete parameter set from the drive to the card, i.e. all parameters except parameters with the NC coding bit set. Once the whole parameter set is stored only the individual modified menu 0 parameter setting is updated.

Advanced parameter changes are only saved to the NV Media Card when Pr mm.000 is set to 'Save Parameters' or a 1001 and the drive reset.

All NV Media Card trips apply, except 'Card Change'. If the data block already contains information it is automatically overwritten.

If the card is removed when Pr 11.042 is set to 3 Pr 11.042 is then automatically set to None (0).

When a new NV Media Card is installed Pr 11.042 must be set back to Auto (3) by the user and the drive reset so the complete parameter set is rewritten to the new NV Media Card if auto mode is still required.

When Pr 11.042 is set to Auto (3) and the parameters in the drive are saved, the NV Media Card is also updated, and therefore the NV Media Card becomes a copy of the drives stored configuration.

At power up, if Pr 11.042 is set to Auto (3), the drive will save the complete parameter set to the NV Media Card. The drive will display 'Card Write' during this operation. This is done to ensure that if a user puts a new NV Media Card in during power down the new NV Media Card will have the correct data.

#### NOTE

When Pr 11.042 is set to Auto (3) the setting of Pr 11.042 itself is saved to the drive EEPROM but not the NV Media Card.

#### 8.3.4 Booting up from the NV Media Card on every power up (Pr 11.042 = Boot (4))

When Pr 11.042 is set to Boot (4) the drive operates the same as Auto mode except when the drive is powered-up. The parameters on the NV Media Card will be automatically transferred to the drive at power up if the following are true:

- A card is inserted in the drive
- Parameter data block 1 exists on the card
- The data in block 1 is type 1 to 4 (as defined in Pr 11.038)
- Pr 11.042 on the card set to Boot (4)

The drive will display 'Booting Parameters' during this operation. If the drive mode is different from that on the card, the drive gives a 'Card Drive Mode' trip and the data is not transferred.

If 'Boot' mode is stored on the copying NV Media Card this makes the copying NV Media Card the master device. This provides a very fast and efficient way of re-programming a number of drives.

#### NOTE

'Boot' mode is saved to the card, but when the card is read, the value of Pr 11.042 is not transferred to the drive.

#### 8.3.5 Booting up from the NV Media Card on every power up (Pr mm.000 = 2001)

It is possible to create a bootable parameter data block by setting Pr mm.000 to 2001 and initiating a drive reset. This data block is created in one operation and is not updated when further parameter changes are made.

Setting Pr mm.000 to 2001 will overwrite the data block 1 on the card if it already exists.

#### 8.3.6 8yyy - Comparing the drive full parameter set with the NV Media Card values

Setting 8yyy in Pr mm.000, will compare the NV Media Card file with the data in the drive. If the compare is successful Pr mm.000 is simply set to 0. If the compare fails a 'Card Compare' trip is initiated.

#### 8.3.7 7yyy / 9999 - Erasing data from the NV Media Card values

Data can be erased from the NV Media Card either one block at a time or all blocks in one go.

- Setting 7yyy in Pr mm.000 will erase NV Media Card data block yyy
- Setting 9999 in Pr mm.000 will erase all the data blocks on a SMARTCARD, but not on an SD Card.

#### 8.3.8 9666 / 9555 - Setting and clearing the NV Media Card warning suppression flag

If the option modules installed to the source and destination drive are different or are in different slots the drive will produce a 'Card Option' trip. If the data is being transferred to a drive of a different voltage or current rating a 'Card Rating' trip will occur. It is possible to suppress these trips by setting the warning suppression flag. If this flag is set the drive will not trip if the option module(s) or drive ratings are different between the source and destination drives. The options module or rating dependent parameters will not be transferred.

- Setting 9666 in Pr mm.000 will set the warning suppression flag
- Setting 9555 in Pr mm.000 will clear the warning suppression flag

#### 8.3.9 9888 / 9777 - Setting and clearing the NV Media Card read only flag

The NV Media Card may be protected from writing or erasing by setting the read only flag. If an attempt is made to write or erase a data block when the read only flag is set, a 'Card Read Only' trip is initiated. When the read only flag is set only codes 6yyy or 9777 are effective.

- Setting 9888 in Pr mm.000 will set the read only flag
- Setting 9777 in Pr mm.000 will clear the read only flag

### 8.4 Data block header information

Each data block stored on a NV Media Card has header information detailing the following:

- NV Media Card File Number (11.037)
- NV Media Card File Type (11.038)
- NV Media Card File Version (11.039)
- NV Media Card File Checksum (11.040)

The header information for each data block which has been used can be viewed in Pr 11.038 to Pr 11.040 by increasing or decreasing the data block number set in Pr 11.037. If there is no data on the card Pr 11.037 can only have a value of 0.

## 8.5 NV Media Card parameters

**Table 8-2 Key to parameter table coding**

RW	Read / Write	ND	No default value
RO	Read only	NC	Not copied
Num	Number parameter	PT	Protected parameter
Bit	Bit parameter	RA	Rating dependant
Txt	Text string	US	User save
Bin	Binary parameter	PS	Power-down save
FI	Filtered	DE	Destination

11.036 {00.029} NV Media Card File Previously Loaded		RO	Num	NC	PT
OL					
RFC-A	⇕		0 to 999	⇒	0
RFC-S					

This parameter shows the number of the data block last transferred from a NV Media Card to the drive. If defaults are subsequently reloaded this parameter is set to 0.

11.037 NV Media Card File Number		RW	Num	NC	PT
OL					
RFC-A	⇕		0 to 999	⇒	0
RFC-S					

This parameter should have the data block number which the user would like the information displayed in Pr 11.038, Pr 11.039 and Pr 11.040.

11.038 NV Media Card File Type		RO	Txt	ND	NC	PT
OL						
RFC-A	⇕		None (0), Open-loop (1), RFC-A (2), RFC-S (3), Regen (4), User Prog (5), Option App (6)	⇒		
RFC-S						

Displays the type/mode of the data block selected with Pr 11.037.

Pr 11.038	String	Type / mode
0	None	No file selected
1	Open-loop	Open-loop mode parameter file
2	RFC-A	RFC-A mode parameter file
3	RFC-S	RFC-S mode parameter file
4	Regen	Regen mode parameter file
5	User Prog	Onboard user program file
6	Option App	Option module application file

11.039 NV Media Card File Version		RO	Num	ND	NC	PT
OL						
RFC-A	⇕		0 to 9999	⇒		
RFC-S						

Displays the version number of the file selected in Pr 11.037.

11.040 NV Media Card File Checksum		RO	Num	ND	NC	PT
OL						
RFC-A	⇕		-2147483648 to 2147483647	⇒		
RFC-S						

Displays the checksum of the data block selected in Pr 11.037.

11.042 {00.030} Parameter Cloning		RW	Txt	NC	US*
OL					
RFC-A	⇕		None (0), Read (1), Program (2), Auto (3), Boot (4)	⇒	None (0)
RFC-S					

\* Only a value of 3 or 4 in this parameter is saved.

### NOTE

If Pr 11.042 is equal to 1 or 2, this value is not transferred to the drive or saved to the EEPROM. If Pr 11.042 is set to 3 or 4 the value is saved to the EEPROM

None (0) = Inactive

Read (1) = Read parameter set from the NV Media Card

Program (2) = Program a parameter set to the NV Media Card

Auto (3) = Auto save

Boot (4) = Boot mode

11.072 NV Media Card Create Special File		RW	Num	NC
OL				
RFC-A	⇕		0 to 1	⇒ 0
RFC-S				

If *NV Media Card Create Special File* (11.072) = 1 when a parameter file is transferred to an NV media card the file is created as a macro file. *NV Media Card Create Special File* (11.072) is reset to 0 after the file is created or the transfer fails.

11.073 NV Media Card Type		RO	Txt	ND	NC	PT
OL						
RFC-A	⇕		None (0), SMART Card (1), SD Card (2)	⇒		
RFC-S						

This will display the type of media card inserted; it will contain one of the following values:

"None" (0) - No NV Media Card has been inserted.

"SMART Card" (1) - A SMARTCARD has been inserted.

"SD Card" (2) - A FAT formatted SD card has been inserted.

11.075 NV Media Card Read-only Flag		RO	Bit	ND	NC	PT
OL						
RFC-A	⇕		Off (0) or On (1)	⇒		
RFC-S						

*NV Media Card Read-only Flag* (11.075) shows the state of the read-only flag for the currently installed card.

11.076		NV Media Card Warning Suppression Flag											
RO	Bit					ND	NC	PT					
OL													
RFC-A	⇕	Off (0) or On (1)					⇒						
RFC-S													

NV Media Card Warning Suppression Flag (11.076) shows the state of the warning flag for the currently installed card.

11.077		NV Media Card File Required Version											
RW	Num					ND	NC	PT					
OL													
RFC-A	⇕	0 to 9999					⇒						
RFC-S													

The value of NV Media Card File Required Version (11.077) is used as the version number for a file when it is created on an NV Media Card. NV Media Card File Required Version (11.077) is reset to 0 when the file is created or the transfer fails.

## 8.6 NV Media Card trips

After an attempt to read, write or erase data from a NV Media Card a trip is initiated if there has been a problem with the command.

See Chapter 11 *Diagnostics* on page 183 for more information on NV Media Card trips.

## 9 Onboard PLC

### 9.1 Onboard PLC and Machine Control Studio

The drive has the ability to store and execute a 16 kB Onboard PLC user program without the need for additional hardware in the form of an option module.

Machine Control Studio is an IEC61131-3 development environment designed for use with Unidrive M and compatible application modules. Machine Control Studio is based on CODESYS from 3S-Smart Software Solutions.

All of the programming languages defined in the IEC standard IEC 61131-3 are supported in the Machine Control Studio development environment.

- ST (Structured text)
- LD (Ladder diagram)
- FBD (Function block diagram)
- IL (Instruction list)
- SFC (Sequential function chart)
- CFC (Continuous Function Chart). CFC is an extension to the standard IEC programming languages

Machine Control Studio provides a complete environment for the development of user programs. Programs can be created, compiled and downloaded to a Unidrive M for execution, via the communications port on the front of the drive. The run-time operation of the compiled program on the target can also be monitored using Machine Control Studio and facilities are provided to interact with the program on the target by setting new values for target variables and parameters.

The Onboard PLC and Machine Control Studio form the first level of functionality in a range of programmable options for Unidrive M.

Machine Control Studio can be downloaded from [www.controltechniques.com](http://www.controltechniques.com).

See the Machine Control Studio help file for more information regarding using Machine Control Studio, creating user programs and downloading user programs to the drive.

### 9.2 Benefits

The combination of the Onboard PLC and Machine Control Studio, means that the drive can replace nano and some micro PLCs in many applications

Machine Control Studio benefits from access to the standard CODESYS function and function block libraries as well as those from third parties. Functions and function blocks available as standard in Machine Control Studio include, but not limited to, the following:

- Arithmetic blocks
- Comparison blocks
- Timers
- Counters
- Multiplexers
- Latches
- Bit manipulation

Typical applications for the Onboard PLC include:

- Ancillary pumps
- Fans and control valves
- Interlocking logic
- Sequences routines
- Custom control words.

### 9.3 Features

The Unidrive M Onboard PLC user program has the following features:

#### 9.3.1 Tasks

The Onboard PLC allows use of two tasks.

- **Clock:** A high priority real time task. The clock task interval can be set from 4 ms to 262 s in multiples of 4 ms. The parameter *Onboard User Program: Clock Task Time Used* (11.051) shows the percentage of the available time used by clock task. A read or write of a drive parameter by the user program takes a finite period of time. It is possible to select up to 10 parameters as fast access parameter which reduced the amount of time it takes for the user program to read from or write to a drive parameter. This is useful when using a clock task with a fast update rate as selecting a parameter for fast access reduces the amount of the clock task resource required to access parameters.
- **Freewheeling:** A non-real time background task. The freewheeling task is scheduled for a short period once every 64 ms. The time for which the task is scheduled will vary depending on the loading of the drive's processor. When scheduled, several scans of the user program may be performed. Some scans may execute in microseconds. However, when the main drive functions are scheduled there will be a pause in the execution of the program causing some scans to take many milliseconds. The parameter *Onboard User Program: Freewheeling Tasks Per Second* (11.050) shows the number of times the freewheeling task has started per second.

#### 9.3.2 Variables

The Onboard PLC supports the use of variables with the data types of Boolean, integer (8 bit, 16 bit and 32 bit, signed and unsigned), floating point (64 bit only), strings and time.

#### 9.3.3 Custom menu

Machine Control Studio can construct a custom drive menu to reside in menu 30 on the drive. The following properties of each parameter can be defined using Machine Control Studio:

- Parameter name
- Number of decimal places
- The units for the parameter to be display on the keypad.
- The minimum, maximum and default values
- Memory handling (i.e. power down save, user save or volatile)
- Data type. The drive provides a limited set of 1 bit, 8 bit, 16 bit and 32 bit integer parameters to create the customer menu.

Parameters in this customer menu can be accessed by the user program and will appear on the keypad.

#### 9.3.4 Limitations

The Onboard PLC user program has the following limitations:

- The flash memory allocated to the Onboard PLC is 16 kB which includes the user program and its header which results in a maximum user program size of about 12 kB
- The Onboard PLC is provided with 2 kB of RAM.
- The drive is rated for 100 program downloads. This limitation is imposed by the flash memory used to store the program within the drive.
- There is only one real-time task with a minimum period of 4 ms.
- The freewheeling background task runs at a low priority. The drive is prioritized to perform the clock task and its major functions first, e.g. motor control, and will use any remaining processing time to execute the freewheeling task as a background activity. As the drive's processor becomes more heavily loaded, less time is spent executing the freewheeling task.
- Breakpoints, single stepping and online program changes are not possible.
- The Graphing tool is not supported.
- The variable data types REAL (32 bit floating point), LWORD (64 bit integer) and WSTRING (Unicode string), and retained variables are not supported.

## 9.4 Onboard PLC parameters

The following parameters are associated with the Onboard PLC user program.

11.047		Onboard User Program: Enable					
RW	Txt					US	
⇅	Stop (0) or Run (1)		⇒	Run (1)			

This parameter stops and starts the user program.

### 0 - Stop the User Program

The onboard user program is stopped. If it is restarted by setting *Onboard User Program: Enable* (11.047) to a non-zero value the background task starts from the beginning.

### 1 - Run the User Program

The user program will execute.

11.048		Onboard User Program: Status					
RO	Txt		NC	PT			
⇅	-2147483648 to 2147483647		⇒				

This parameter is read-only and indicates the status of the user program in the drive. The user program writes the value to this parameter.

0: Stopped

1: Running

2: Exception

3: No user program present

11.049		Onboard User Program: Programming Events					
RO	Uni		NC	PT	PS		
⇅	0 to 65535		⇒				

This parameter holds the number of times an Onboard PLC user program download has taken place and is 0 on dispatch from the factory. The drive is rated for one hundred program downloads. This parameter is not altered when defaults are loaded.

11.050		Onboard User Program: Freewheeling Tasks Per Second					
RO	Uni		NC	PT			
⇅	0 to 65535		⇒				

This parameter shows the number of times the freewheeling task has started per second.

11.051		Onboard User Program: Clock Task Time Used					
RO			NC	PT			
⇅	0.0 to 100.0 %		⇒				

This parameter shows the percentage of the available time used by the user program clock task.

11.055		Onboard User Program: Clock Task Scheduled Interval					
RO			NC	PT			
⇅	0 to 262128 ms		⇒				

This parameter shows the interval at which the clock task is scheduled to run at in ms.

## 9.5 Onboard PLC trips

If the drive detects an error in the user program it will initiate a User Program trip. The sub-trip number for the User Program trip details the reason for the error. See Chapter 11 *Diagnostics* on page 183 for more information on the User Program trip.

## 10 Advanced parameters

This is a quick reference to all parameters in the drive showing units, ranges limits etc, with block diagrams to illustrate their function. Full descriptions of the parameters can be found in the *Parameter Reference Guide*.



**These advanced parameters are listed for reference purposes only. The lists in this chapter do not include sufficient information for adjusting these parameters. Incorrect adjustment can affect the safety of the system, and damage the drive and or external equipment. Before attempting to adjust any of these parameters, refer to the *Parameter Reference Guide*.**

**Table 10-1 Menu descriptions**

Menu	Description
0	Commonly used basic set up parameters for quick / easy programming
1	Frequency / Speed reference
2	Ramps
3	Speed feedback and speed control
4	Torque and current control
5	Motor control
6	Sequencer and clock
7	Analog I/O, Temperature monitoring
8	Digital I/O
9	Programmable logic, motorized pot, binary sum, timers and scope
10	Status and trips
11	Drive set-up and identification, serial communications
12	Threshold detectors and variable selectors
13	Standard motion control
14	User PID controller
15	Option module slot 1 set-up menu
16	Option module slot 2 set-up menu
17	Option module slot 3 set-up menu
18	General option module application menu 1
19	General option module application menu 2
20	General option module application menu 3
21	Second motor parameters
22	Menu 0 set-up
23	Not allocated
28	Reserved menu
29	Reserved menu
30	Onboard user programming application menu
Slot 1	Slot 1 option menus*
Slot 2	Slot 2 option menus*
Slot 3	Slot 3 option menus*

\* Only displayed when the option modules are installed.

### Operation mode abbreviations:

#### Open-loop:

Sensorless control for induction motors

#### RFC-A Sensorless:

Asynchronous Rotor Flux Sensorless Control for induction motors

**RFC-S Sensorless:** Synchronous Rotor Flux Sensorless Control for synchronous motors including permanent magnet motors.

#### Default abbreviations:

Standard default value (50 Hz AC supply frequency)

USA default value (60 Hz AC supply frequency)

#### NOTE

Parameter numbers shown in brackets {...} are the equivalent Menu 0 parameters. Some Menu 0 parameters appear twice since their function depends on the operating mode.

The Range - RFC-A / S column applies to both RFC-A and RFC-S. For some parameters, this column applies to only one of these modes, this is indicated accordingly in the Default columns.

In some cases, the function or range of a parameter is affected by the setting of another parameter. The information in the lists relates to the default condition of any parameters affected in this way.

**Table 10-2 Key to parameter table coding**

Coding	Attribute
<b>RW</b>	Read/Write: can be written by the user
<b>RO</b>	Read only: can only be read by the user
<b>Bit</b>	1 bit parameter: 'On' or 'Off' on the display
<b>Num</b>	Number: can be uni-polar or bi-polar
<b>Txt</b>	Text: the parameter uses text strings instead of numbers.
<b>Bin</b>	Binary parameter
<b>IP</b>	IP Address parameter
<b>Mac</b>	Mac Address parameter
<b>Date</b>	Date parameter
<b>Time</b>	Time parameter
<b>Chr</b>	Character parameter
<b>FI</b>	Filtered: some parameters which can have rapidly changing values are filtered when displayed on the drive keypad for easy viewing.
<b>DE</b>	Destination: This parameter selects the destination of an input or logic function.
<b>RA</b>	Rating dependent: this parameter is likely to have different values and ranges with drives of different voltage and current ratings. Parameters with this attribute will be transferred to the destination drive by non-volatile storage media when the rating of the destination drive is different from the source drive and the file is a parameter file. However, the values will be transferred if only the current rating is different and the file is a difference from default type file.
<b>ND</b>	No default: The parameter is not modified when defaults are loaded
<b>NC</b>	Not copied: not transferred to or from non-volatile media during copying.
<b>PT</b>	Protected: cannot be used as a destination.
<b>US</b>	User save: parameter saved in drive EEPROM when the user initiates a parameter save.
<b>PS</b>	Power-down save: parameter automatically saved in drive EEPROM when the under volts (UV) state occurs.

**Table 10-3 Feature look-up table**

Feature	Related parameters (Pr)												
Acceleration rates	02.010	02.011 to 02.019		02.032	02.033	02.034	02.002						
Analog speed reference 1	01.036	07.010	07.001	07.007	07.008	07.009	07.025	07.026	07.030				
Analog speed reference 2	01.037	07.014	01.041	07.002	07.011	07.012	07.013	07.028	07.031				
Analog I/O	Menu 7												
Analog input 1	07.001	07.007	07.008	07.009	07.010	07.025	07.026	07.028	07.030	07.040	07.043	7.051	
Analog input 2	07.002	07.011	07.012	07.013	07.014	07.022	07.023	07.027	07.031	07.041	07.044		
Analog input 3	07.003	07.015	07.016	07.017	07.018	07.032	07.042	07.045	07.046	07.047	07.048	07.049	07.050
Analog output 1	07.019	07.020											
Analog output 2	07.022	07.023											
Application menu	Menu 18			Menu 19		Menu 20							
At speed indicator bit	03.006	03.007	03.009	10.006	10.005	10.007							
Auto reset	10.034	10.035	10.036	10.001									
Autotune	05.010	05.012	05.017	05.024	05.025	05.029	05.030	05.059	05.060	05.062			
Binary sum	09.029	09.030	09.031	09.032	09.033	09.034							
Bipolar speed	01.010												
Brake control	12.040 to 12.055												
Braking	10.011	10.010	10.030	10.031	06.001	02.004	02.002	10.012	10.039	10.040			
Catch a spinning motor	06.009	05.040											
Coast to stop	06.001												
Comms	11.023 to 11.026												
Copying	11.042	11.036 to 11.040											
Cost - per kWh electricity	06.016	06.017	06.024	06.025	06.026	06.027	06.028						
Current controller	04.013	04.014											
Current feedback	04.001	04.002	04.017	04.004	04.012	04.020	04.023	04.024	04.026	10.008	10.009	10.017	
Current limits	04.005	04.006	04.007	04.018	04.015	04.019	04.016	05.007	05.010	10.008	10.009	10.017	
DC bus voltage	05.005	02.008											
DC injection braking	06.006	06.007	06.001										
Deceleration rates	02.020	02.021 to 02.029		02.004	02.035 to 02.037		02.002	02.008	06.001	10.030	10.031	10.039	02.009
Defaults	11.043	11.046											
Digital I/O	Menu 8												
Digital I/O read word	08.020												
Digital I/O 1 T24	08.001	08.011	08.021	08.031									
Digital I/O 2 T25	08.002	08.012	08.022	08.032									
Digital I/O 3 T26	08.003	08.013	08.023	08.033									
Digital input 4 T27	08.004	08.014	08.024										
Digital input 5 T28	08.005	08.015	08.025										
Digital input 6 T29	08.006	08.016	08.026										
Digital lock	13.010	13.001 to 13.009			13.011	13.012	13.016	03.022	03.023	13.019 to 13.023			
Digital output T22	08.008	08.018	08.028										
Direction	10.013	06.030	06.031	01.003	10.014	02.001	03.002	08.003	08.004	10.040			
Drive active	10.002	10.040											
Drive derivative	11.028												
Drive healthy	10.001	08.027	08.007	08.017	10.036	10.040							
Dynamic performance	05.026												
Dynamic V/F	05.013												
Enable	06.010	06.015	06.029	08.009	08.040								
External trip	10.032	08.010	08.007										
Fan speed	06.045	07.036											
Fast disable	06.029												
Field weakening - induction motor	05.029	05.030	01.006	05.028									
Field weakening - PM motor	05.022	01.006	05.009										
Filter change	06.019	06.018	06.021	06.022	06.023								
Frequency reference selection	01.014	01.015											
Heavy duty rating	05.007	11.032											
High stability space vector modulation	05.019												
I/O sequencer	06.030	06.031	06.032	06.033	06.034	06.042	06.043	06.041					
Inertia compensation	02.038	05.012	04.022	03.018									
Jog reference	01.005	02.019	02.029										
Keypad reference	01.017	01.014	01.043	01.051	06.012	06.013							
Kt	05.032												
Limit switches	06.035	06.036											

Feature	Related parameters (Pr)											
Line power supply loss	06.003	10.015	10.016	05.005	06.048							
Local position reference	13.020 to 13.023											
Logic function 1	09.001	09.004	09.005	09.006	09.007	09.008	09.009	09.010				
Logic function 2	09.002	09.014	09.015	09.016	09.017	09.018	09.019	09.020				
Low voltage supply	06.044											
Maximum speed	01.006											
Menu 0 set-up	Menu 22											
Minimum speed	01.007	10.004										
Modules - number of	11.035											
Motor map	05.006	05.007	05.008	05.009	05.010	05.011						
Motor map 2	Menu 21		11.045									
Motorized potentiometer	09.021	09.022	09.023	09.024	09.025	09.026	09.027	09.028				
Offset speed reference	01.004	01.038	01.009									
Onboard PLC	11.047 to 11.051											
Open loop vector mode	05.014	05.017										
Operating mode	00.048	11.031	03.024	05.014								
Orientation	13.010	13.013 to 13.015										
Output	05.001	05.002	05.003	05.004								
Overspeed threshold	03.008											
PID controller	Menu 14											
Positive logic	08.029											
Power up parameter	11.022	11.021										
Precision reference	01.018	01.019	01.020	01.044								
Preset speeds	01.015	01.021 to 01.028		01.016	01.014	01.042	01.045 to 01.048		01.050			
Programmable logic	Menu 9											
Quasi square operation	05.020											
Ramp (accel / decel) mode	02.004	02.008	06.001	02.002	02.003	10.030	10.031	10.039				
Rated speed autotune	05.016	05.008										
Regenerating	10.010	10.011	10.030	10.031	06.001	02.004	02.002	10.012	10.039	10.040		
Relative jog	13.017 to 13.019											
Relay output	08.007	08.017	08.027									
Reset	10.033	08.002	08.022	10.034	10.035	10.036	10.001	10.038				
RFC-A Sensorless	03.024	03.042	04.012									
S ramp	02.006	02.007										
Sample rates	05.018											
Safe Torque Off input	08.009	08.040										
Security code	11.030	11.044										
Serial comms	11.023 to 11.027			11.020								
Skip speeds	01.029	01.030	01.031	01.032	01.033	01.034	01.035					
Slip compensation	05.027	05.008										
NV media card	11.036 to 11.040			11.042								
Firmware version	11.029	11.034	11.062									
Speed controller	03.010 to 03.017			03.019	03.020	03.021						
Speed feedback	03.002	03.003	03.004									
Speed feed forward	01.039	01.040										
Speed feedback - drive	03.026	03.080										
Speed reference selection	01.014	01.015	01.049	01.050	01.001							
Status word	10.040											
Supply	06.044	05.005										
Switching frequency	05.018	05.035	07.034	07.035								
Thermal protection - drive	05.018	05.035	07.004	07.005	07.006	07.034	07.035	07.036	10.018			
Thermal protection - motor	04.015	05.007	04.019	04.016	04.025	07.015						
Thermistor input	07.003	07.015	07.046	07.047	07.048	07.049	07.050					
Threshold detector 1	12.001	12.003 to 12.007										
Threshold detector 2	12.002	12.023 to 12.027										
Time - filter change	06.019	06.018	06.021	06.022	06.023							
Time - powered up log	06.019	06.020										
Time - run log	06.019											
Torque	04.003	04.026	05.032									
Torque mode	04.008	04.011	04.009	04.010								
Trip detection	10.037	10.038	10.020 to 10.029									
Trip log	10.020 to 10.029			10.041 to 10.060			10.070 to 10.079					
Under voltage	05.005	10.016	10.015									
Variable selector 1	12.008 to 12.016											
Variable selector 2	12.028 to 12.036											

Feature	Related parameters (Pr)											
Voltage controller	05.031											
Voltage mode	05.015	05.017										
Voltage rating	11.033	05.009	05.005									
Voltage supply	06.044	05.005										
Warning	10.019	10.012	10.017	10.018	10.040							
Zero speed indicator bit	03.005	10.003										

## 10.1 Parameter ranges and Variable minimum/maximums:

Some parameters in the drive have a variable range with a variable minimum and a variable maximum values which is dependent on one of the following:

- The settings of other parameters
- The drive rating
- The drive mode
- Combination of any of the above

The tables below give the definition of variable minimum/maximum and the maximum range of these.

<b>VM_AC_VOLTAGE</b>		Range applied to parameters showing AC voltage
Units	V	
Range of [MIN]	0	
Range of [MAX]	0 to 930	
Definition	VM_AC_VOLTAGE[MAX] is drive voltage rating dependent. See Table 10-4 VM_AC_VOLTAGE[MIN] = 0	

<b>VM_AC_VOLTAGE_SET</b>		Range applied to the AC voltage set-up parameters
Units	V	
Range of [MIN]	0	
Range of [MAX]	0 to 690	
Definition	VM_AC_VOLTAGE_SET[MAX] is drive voltage rating dependent. See Table 10-4 VM_AC_VOLTAGE_SET[MIN] = 0	

<b>VM_ACCEL_RATE</b>		Maximum applied to the ramp rate parameters
<b>Units</b>	s / 100 Hz, s / 1000 rpm, s / 1000 mm/s	
<b>Range of [MIN]</b>	Open-loop: 0.0 RFC-A, RFC-S: 0.000	
<b>Range of [MAX]</b>	Open-loop: 0.0 to 3200.0 RFC-A, RFC-S: 0.000 to 3200.000	
<b>Definition</b>	<p>A maximum needs to be applied to the ramp rate parameters because the units are a time for a change of speed from zero to a defined level or to maximum speed. The defined level is 100 Hz for Open-loop mode and 1000rpm or 1000mm/s for RFC-A and RFC-S modes. If the change of speed is to the maximum speed then changing the maximum speed changes the actual ramp rate for a given ramp rate parameter value. The variable maximum calculation ensures that longest ramp rate (parameter at its maximum value) is not slower than the rate with the defined level, i.e. 3200.00 s / Hz for Open-loop mode, and 3200.000 s / 1000 rpm or 3200.000 s / 1000 mm/s for RFC-A and RFC-S modes.</p> <p>The maximum frequency/speed is taken from <i>Maximum Reference Clamp</i> (01.006) if <i>Select Motor 2 Parameters</i> (11.045) = 0, or <i>M2 Maximum Reference Clamp</i> (21.001) if <i>Select Motor 2 Parameters</i> (11.045) = 1.</p> <p>Open-loop mode VM_ACCEL_RATE[MIN] = 0.0</p> <p>If Ramp Rate Units (02.039) = 0: VM_ACCEL_RATE[MAX] = 3200.0 Otherwise: VM_ACCEL_RATE[MAX] = 3200.0 x Maximum frequency / 100.0</p> <p>RFC-A, RFC-S modes VM_ACCEL_RATE[MIN] = 0.000</p> <p>If Ramp Rate Units (02.039) = 0: VM_ACCEL_RATE[MAX] = 3200.000 Otherwise: VM_ACCEL_RATE[MAX] = 3200.000 x Maximum speed / 1000.0</p>	

<b>VM_DC_VOLTAGE</b>		Range applied to parameters showing DC voltage
<b>Units</b>	V	
<b>Range of [MIN]</b>	0	
<b>Range of [MAX]</b>	0 to 1190	
<b>Definition</b>	<p>VM_DC_VOLTAGE[MAX] is the full scale DC bus voltage feedback (over voltage trip level) for the drive. This level is drive voltage rating dependent. See Table 10-4</p> <p>VM_DC_VOLTAGE[MIN] = 0</p>	

<b>VM_DC_VOLTAGE_SET</b>		Range applied to DC voltage reference parameters
<b>Units</b>	V	
<b>Range of [MIN]</b>	0	
<b>Range of [MAX]</b>	0 to 1150	
<b>Definition</b>	<p>VM_DC_VOLTAGE_SET[MAX] is drive voltage rating dependent. See Table 10-4</p> <p>VM_DC_VOLTAGE_SET[MIN] = 0</p>	

<b>VM_DRIVE_CURRENT</b>		Range applied to parameters showing current in A
<b>Units</b>	A	
<b>Range of [MIN]</b>	-99999.999 to 0.000	
<b>Range of [MAX]</b>	0.000 to 99999.999	
<b>Definition</b>	<p>VM_DRIVE_CURRENT[MAX] is equivalent to the full scale (over current trip level) or Kc value for the drive and is given by <i>Full Scale Current Kc</i> (11.061).</p> <p>VM_DRIVE_CURRENT[MIN] = - VM_DRIVE_CURRENT[MAX]</p>	

<b>VM_DRIVE_CURRENT_UNIPOLAR</b>		Unipolar version of VM_DRIVE_CURRENT
<b>Units</b>	A	
<b>Range of [MIN]</b>	0.000	
<b>Range of [MAX]</b>	0.000 to 99999.999	
<b>Definition</b>	VM_DRIVE_CURRENT_UNIPOLAR[MAX] = VM_DRIVE_CURRENT[MAX] VM_DRIVE_CURRENT_UNIPOLAR[MIN] = 0.000	

<b>VM_HIGH_DC_VOLTAGE</b>		Range applied to parameters showing high DC voltage
<b>Units</b>	V	
<b>Range of [MIN]</b>	0	
<b>Range of [MAX]</b>	0 to 1500	
<b>Definition</b>	VM_HIGH_DC_VOLTAGE[MAX] is the full scale DC bus voltage feedback for the high DC bus voltage measurement which can measure the voltage if it goes above the normal full scale value. This level is drive voltage rating dependent. See Table 10-4 VM_HIGH_DC_VOLTAGE[MIN] = 0	

<b>VM_LOW_UNDER_VOLTS</b>		Range applied the low under-voltage threshold
<b>Units</b>	V	
<b>Range of [MIN]</b>	24	
<b>Range of [MAX]</b>	24 to 1150	
<b>Definition</b>	If <i>Back-up Mode Enable</i> (06.068) = 0: VM_LOW_UNDER_VOLTS[MAX] = VM_STD_UNDER_VOLTS[MIN] If <i>Back-up Mode Enable</i> (06.068) = 1: VM_LOW_UNDER_VOLTS[MAX] = VM_STD_UNDER_VOLTS[MIN] / 1.1. VM_LOW_UNDER_VOLTS[MIN] = 24.	

<b>VM_MIN_SWITCHING_FREQUENCY</b>		Range applied to the minimum switching frequency parameter
<b>Units</b>	User units	
<b>Range of [MIN]</b>	0	
<b>Range of [MAX]</b>	0 to 6	
<b>Definition</b>	VM_MIN_SWITCHING_FREQUENCY[MAX] = <i>Maximum Switching Frequency</i> (05.018) VM_MIN_SWITCHING_FREQUENCY[MIN] = 0 for motor control modes, or 1 for Regen mode (subject to the maximum)	

VM_MOTOR1_CURRENT_LIMIT VM_MOTOR2_CURRENT_LIMIT		Range applied to current limit parameters
<b>Units</b>	%	
<b>Range of [MIN]</b>	0.0	
<b>Range of [MAX]</b>	0.0 to 1000.0	
<b>Definition</b>	<p>VM_MOTOR1_CURRENT_LIMIT[MIN] = 0.0</p> <p><b>Open-loop</b>            VM_MOTOR1_CURRENT_LIMIT[MAX] = (I<sub>Tlimit</sub> / I<sub>Trated</sub>) x 100 %            Where:  <math>I_{Tlimit} = I_{MaxRef} \times \cos(\sin^{-1}(I_{Mrated} / I_{MaxRef}))</math>  <math>I_{Mrated} = Pr\ 05.007 \sin \phi</math>  <math>I_{Trated} = Pr\ 05.007 \times \cos \phi</math>  <math>\cos \phi = Pr\ 05.010</math>  <math>I_{MaxRef}</math> is 0.7 x Pr <b>11.061</b> when the motor rated current set in Pr <b>05.007</b> is less than or equal to Pr <b>11.032</b> (i.e. Heavy duty), otherwise it is the lower of 0.7 x Pr <b>11.061</b> or 1.1 x Pr <b>11.060</b> (i.e. Normal duty).</p> <p><b>RFC-A</b>            VM_MOTOR1_CURRENT_LIMIT[MAX] = (I<sub>Tlimit</sub> / I<sub>Trated</sub>) x 100 %            Where:  <math>I_{Tlimit} = I_{MaxRef} \times \cos(\sin^{-1}(I_{Mrated} / I_{MaxRef}))</math>  <math>I_{Mrated} = Pr\ 05.007 \times \cos \phi_1</math>  <math>I_{Trated} = Pr\ 05.007 \times \sin \phi_1</math>  <math>\phi_1 = \cos^{-1}(Pr\ 05.010) + \phi_2</math>. <math>\phi_1</math> is calculated during an autotune. See the variable minimum / maximum calculations in the <i>Parameter Reference Guide</i> for more information regarding <math>\phi_2</math>.  <math>I_{MaxRef}</math> is 0.9 x Pr <b>11.061</b> when the motor rated current set in Pr <b>05.007</b> is less than or equal to Pr <b>11.032</b> (i.e. Heavy duty), otherwise it is the lower of 0.9 x Pr <b>11.061</b> or 1.1 x Pr <b>11.060</b> (i.e. Normal duty).</p> <p><b>RFC-S and Regen</b>            VM_MOTOR1_CURRENT_LIMIT[MAX] = (I<sub>MaxRef</sub> / Pr <b>05.007</b>) x 100 %            Where:  <math>I_{MaxRef}</math> is 0.9 x Pr <b>11.061</b> when the motor rated current set in Pr <b>05.007</b> is less than or equal to Pr <b>11.032</b> (i.e. Heavy duty), otherwise it is the lower of 0.9 x Pr <b>11.061</b> or 1.1 x Pr <b>11.060</b> (i.e. Normal duty).</p> <p>For VM_MOTOR2_CURRENT_LIMIT[MAX] use Pr <b>21.007</b> instead of Pr <b>05.007</b> and Pr <b>21.010</b> instead of Pr <b>05.010</b>.</p>	

VM_NEGATIVE_REF_CLAMP1 VM_NEGATIVE_REF_CLAMP2		Limits applied to the negative frequency or speed clamp																			
<b>Units</b>	Open-loop: Hz RFC-A, RFC-S: rpm or mm/s																				
<b>Range of [MIN]</b>	Open-loop: -550.0 to 0.0 RFC-A, RFC-S: -50000.0 to 0.0																				
<b>Range of [MAX]</b>	Open-loop: 0.0 to 550.0 RFC-A, RFC-S: 0.0 to 50000.0																				
<b>Definition</b>	<table border="1"> <thead> <tr> <th>Negative Reference Clamp Enable (01.008)</th> <th>Bipolar Reference Enable (01.010)</th> <th>VM_NEGATIVE_REF_CLAMP1[MIN]</th> <th>VM_NEGATIVE_REF_CLAMP1[MAX]</th> </tr> </thead> <tbody> <tr> <td>0</td> <td>0</td> <td>0.0</td> <td>Pr 01.006</td> </tr> <tr> <td>0</td> <td>1</td> <td>0.0</td> <td>0.0</td> </tr> <tr> <td>1</td> <td>X</td> <td>-VM_POSITIVE_REF_CLAMP1[MAX]</td> <td>0.0</td> </tr> </tbody> </table>	Negative Reference Clamp Enable (01.008)	Bipolar Reference Enable (01.010)	VM_NEGATIVE_REF_CLAMP1[MIN]	VM_NEGATIVE_REF_CLAMP1[MAX]	0	0	0.0	Pr 01.006	0	1	0.0	0.0	1	X	-VM_POSITIVE_REF_CLAMP1[MAX]	0.0				
	Negative Reference Clamp Enable (01.008)	Bipolar Reference Enable (01.010)	VM_NEGATIVE_REF_CLAMP1[MIN]	VM_NEGATIVE_REF_CLAMP1[MAX]																	
	0	0	0.0	Pr 01.006																	
	0	1	0.0	0.0																	
1	X	-VM_POSITIVE_REF_CLAMP1[MAX]	0.0																		
VM_NEGATIVE_REF_CLAMP2 is defined in the same way except that Pr 21.001 is used instead of Pr 01.006.																					

VM_POSITIVE_REF_CLAMP1 VM_POSITIVE_REF_CLAMP2		Limits applied to the positive frequency or speed reference clamp													
<b>Units</b>	Open-loop: Hz RFC-A, RFC-S: rpm or mm/s														
<b>Range of [MIN]</b>	Open-loop: 0.0 RFC-A, RFC-S: 0.0														
<b>Range of [MAX]</b>	Open-loop: 550.0 RFC-A, RFC-S: 0.0 to 50000.0														
<b>Definition</b>	VM_POSITIVE_REF_CLAMP1[MAX] defines the range of the positive reference clamp, <i>Maximum Reference Clamp</i> (01.006), which in turn limit the references. In RFC-A and RFC-S modes a limit is applied so that the position feedback does not exceed the speed where the drive can no longer interpret the feedback signal correctly as given in the table below. The limit is based on the position feedback device selected with <i>Motor Control Feedback Select</i> (03.026). It is possible to disable this limit if the <i>RFC Feedback Mode</i> (03.024) $\geq 1$ so that the motor can be operated at a speed above the level where the drive can interpret the feedback in sensorless mode. It should be noted that the position feedback device itself may have a maximum speed limit that is lower than those given in the table. Care should be taken not to exceed a speed that would cause damage to the position feedback device.														
	<table border="1"> <thead> <tr> <th>Feedback device</th> <th>VM_POSITIVE_REF_CLAMP1[MAX]</th> </tr> </thead> <tbody> <tr> <td>AB, AB Servo</td> <td>(500 kHz x 60 / rotary lines per revolution) rpm (500 kHz / linear line pitch in mm) mm/s</td> </tr> <tr> <td>FD, FR, FD Servo, FR Servo</td> <td>(500 kHz x 60 / rotary lines per revolution)/2 rpm (500 kHz / linear line pitch in mm)/2 mm/s</td> </tr> <tr> <td>SC, SC Hiper, SC EnDat, SC SSI, SC Servo</td> <td>(500 kHz x 60 / sine waves per revolution) rpm (500 kHz x linear line pitch in mm) mm/s</td> </tr> <tr> <td>Any other device</td> <td>50000.0 rpm or mm/s</td> </tr> </tbody> </table>	Feedback device	VM_POSITIVE_REF_CLAMP1[MAX]	AB, AB Servo	(500 kHz x 60 / rotary lines per revolution) rpm (500 kHz / linear line pitch in mm) mm/s	FD, FR, FD Servo, FR Servo	(500 kHz x 60 / rotary lines per revolution)/2 rpm (500 kHz / linear line pitch in mm)/2 mm/s	SC, SC Hiper, SC EnDat, SC SSI, SC Servo	(500 kHz x 60 / sine waves per revolution) rpm (500 kHz x linear line pitch in mm) mm/s	Any other device	50000.0 rpm or mm/s				
	Feedback device	VM_POSITIVE_REF_CLAMP1[MAX]													
	AB, AB Servo	(500 kHz x 60 / rotary lines per revolution) rpm (500 kHz / linear line pitch in mm) mm/s													
	FD, FR, FD Servo, FR Servo	(500 kHz x 60 / rotary lines per revolution)/2 rpm (500 kHz / linear line pitch in mm)/2 mm/s													
	SC, SC Hiper, SC EnDat, SC SSI, SC Servo	(500 kHz x 60 / sine waves per revolution) rpm (500 kHz x linear line pitch in mm) mm/s													
Any other device	50000.0 rpm or mm/s														
In open-loop mode VM_POSITIVE_REF_CLAMP1[MAX] is fixed at 550.0 Hz															
In RFC mode a limit is applied to the speed reference of 550 x 60 / Motor pole pairs. Therefore, with a 4 pole motor the limit for VM_POSITIVE_REF_CLAMP1[MAX] will be 16,500 rpm.															
VM_POSITIVE_REF_CLAMP1[MIN] = 0.0															
VM_POSITIVE_REF_CLAMP2 is defined in the same way as VM_POSITIVE_REF_CLAMP1 except VM_POSITIVE_REF_CLAMP2[MAX] defines the range of the positive reference clamp, <i>M2 Maximum Reference Clamp</i> (21.001), which in turn limits the references.															

<b>VM_POWER</b>		Range applied to parameters that either set or display power
<b>Units</b>	kW	
<b>Range of [MIN]</b>	-99999.999 to 0.000	
<b>Range of [MAX]</b>	0.000 to 99999.999	
<b>Definition</b>	<p>VM_POWER[MAX] is rating dependent and is chosen to allow for the maximum power that can be output by the drive with maximum a.c. output voltage, at maximum controlled current and unity power factor.</p> <p><math>VM\_POWER[MAX] = \sqrt{3} \times VM\_AC\_VOLTAGE[MAX] \times VM\_DRIVE\_CURRENT[MAX] / 1000</math></p> <p><math>VM\_POWER[MIN] = -VM\_POWER[MAX]</math></p>	

<b>VM_RATED_CURRENT</b>		Range applied to rated current parameters
<b>Units</b>	A	
<b>Range of [MIN]</b>	0.000	
<b>Range of [MAX]</b>	0.000 to 99999.999	
<b>Definition</b>	<p>VM_RATED_CURRENT [MAX] = <i>Maximum Rated Current</i> (11.060) and is dependent on the drive rating. This is the Normal Duty rating of the drive.</p> <p><math>VM\_RATED\_CURRENT [MIN] = 0.00</math></p>	

<b>VM_REGEN_REACTIVE</b>		Range applied to the reactive current reference in Regen mode
<b>Units</b>	%	
<b>Range of [MIN]</b>	-1000.0 to 0.0	
<b>Range of [MAX]</b>	0.0 to 1000.0	
<b>Definition</b>	<p>A maximum is applied to the reactive current reference parameter so that the combined current reference for the active and reactive currents does not exceed IMaxRef.</p> <p><math>VM\_REGEN\_REACTIVE = v(VM\_MOTOR1\_CURRENT\_LIMIT2 - ILimit2)</math></p> <p>where</p> <p>ILimit gives the highest level of the active current reference that can occur. This value is defined by the current limit values. If the current limits are all set to their maximum values (i.e. VM_MOTOR1_CURRENT_LIMIT) then there is no current capability left for the reactive current. However, if the current limits are reduced the resulting headroom can be used for the reactive current. ILimit is defined by a combination of all the current limits excluding any reduction of the current limit due to the motor thermal model. It should be noted that if Island Detection Enable (03.030) = 1 then VM_REGEN_REACTIVE is reduced by 5% to allow for the islanding system injection current.</p> <p><math>VM\_REGEN\_REACTIVE[MIN] = - VM\_REGEN\_REACTIVE[MAX]</math></p>	

<b>VM_SPEED</b>		Range applied to parameters showing speed
<b>Units</b>	Open-loop, RFC-A, RFC-S: rpm or mm/s	
<b>Range of [MIN]</b>	Open-loop, RFC-A, RFC-S: -50000.0 to 0.0	
<b>Range of [MAX]</b>	Open-loop, RFC-A, RFC-S: 0.0 to 50000.0	
<b>Definition</b>	<p>This variable minimum/maximum defines the range of speed monitoring parameters. To allow headroom for overshoot the range is set to twice the range of the speed references.</p> <p><math>VM\_SPEED[MAX] = 2 \times VM\_SPEED\_FREQ\_REF[MAX]</math></p> <p><math>VM\_SPEED[MIN] = 2 \times VM\_SPEED\_FREQ\_REF[MIN]</math></p>	

<b>VM_SPEED_FREQ_KEYPAD_REF</b>		Range applied Keypad Control Mode Reference (01.017)	
<b>Units</b>	Open-loop: Hz RFC-A, RFC-S: rpm or mm/s		
<b>Range of [MIN]</b>	Open-loop: -550.0 to 550.0 RFC-A, RFC-S: -50000.0 to 50000.0		
<b>Range of [MAX]</b>	Open-loop: 0.0 to 550.0 RFC-A, RFC-S: 0.0 to 50000.0		
<b>Definition</b>	This variable maximum is applied to <i>Keypad Control Mode Reference</i> (01.017). The maximum applied to these parameters is the same as other frequency reference parameters.		
	VM_SPEED_FREQ_USER_REFS [MAX] = VM_SPEED_FREQ_REF[MAX]		
	However the minimum is dependent on <i>Negative Reference Clamp Enable</i> (01.008) and <i>Bipolar Reference Enable</i> (01.010).		
	<b>Negative Reference Clamp Enable (01.008)</b>	<b>Bipolar Reference Enable (01.010)</b>	<b>VM_SPEED_FREQ_USER_REFS[MIN]</b>
	0	0	If <i>Select Motor 2 Parameters</i> (11.045) = 0 <i>Minimum Reference Clamp</i> (01.007), otherwise <i>M2 Minimum Reference Clamp</i> (21.002)
	0	1	-VM_SPEED_FREQ_REF[MAX]
1	0	0.0	
1	1	-VM_SPEED_FREQ_REF[MAX]	

<b>VM_SPEED_FREQ_REF</b>		Range applied to the frequency or speed reference parameters	
<b>Units</b>	Open-loop: Hz RFC-A, RFC-S: rpm or mm/s		
<b>Range of [MIN]</b>	Open-loop: -550.0 to 0.0 RFC-A, RFC-S: -50000.0 to 0.0		
<b>Range of [MAX]</b>	Open-loop: 0.0 to 550.0 RFC-A, RFC-S: 0.0 to 50000.0		
<b>Definition</b>	This variable minimum/maximum is applied throughout the frequency and speed reference system so that the references can vary in the range from the minimum to maximum clamps.		
	<b>Negative Reference Clamp Enable (01.008)</b>	<b>VM_SPEED_FREQ_REF[MAX] if Select Motor 2 Parameters (11.045) = 0</b>	<b>VM_SPEED_FREQ_REF[MAX] if Select Motor 2 Parameters (11.045) = 1</b>
	0	<i>Maximum Reference Clamp</i> (01.006)	M2 <i>Maximum Reference Clamp</i> (21.001)
	1	<i>Maximum Reference Clamp</i> (01.006) or <i>Minimum Reference Clamp</i> (01.007) whichever the larger	M2 <i>Maximum Reference Clamp</i> (21.001) or <i>Minimum Reference Clamp</i> (21.002) whichever the larger
VM_SPEED_FREQ_REF[MIN] = -VM_SPEED_FREQ_REF[MAX].			

<b>VM_SPEED_FREQ_REF_UNIPOLAR</b>		Unipolar version of VM_SPEED_FREQ_REF	
<b>Units</b>	Open-loop: Hz RFC-A, RFC-S: rpm or mm/s		
<b>Range of [MIN]</b>	Open-loop: 0.0 RFC-A, RFC-S: 0.0		
<b>Range of [MAX]</b>	Open-loop: 0.0 to 550.0 RFC-A, RFC-S: 0.0 to 50000.0		
<b>Definition</b>	VM_SPEED_FREQ_REF_UNIPOLAR[MAX] = VM_SPEED_FREQ_REF[MAX]		
	VM_SPEED_FREQ_REF_UNIPOLAR[MIN] = 0.0		

VM_SPEED_FREQ_USER_REFS		Range applied to some analog reference parameters	
Units	Open-loop: Hz RFC-A, RFC-S: rpm or mm/s		
Range of [MIN]	Open-loop: -550.00 to 550.00 RFC-A, RFC-S: -50000.0 to 50000.0		
Range of [MAX]	Open-loop: 0.00 to 550.00 RFC-A, RFC-S: 0.0 to 50000.0		
Definition	VM_SPEED_FREQ_USER_REFS[MAX] = VM_SPEED_FREQ_REF[MAX]		
	<b>Negative Reference Clamp Enable (01.008)</b>	<b>Bipolar Reference Enable (01.010)</b>	<b>VM_SPEED_FREQ_USER_REFS [MIN]</b>
	0	0	Pr 01.007
	0	1	-VM_SPEED_FREQ_REF[MAX]
	1	0	0.0
	1	1	-VM_SPEED_FREQ_REF[MAX]
If the second motor map is selected (Pr 11.045 = 1) Pr 21.002 is used instead of Pr 01.007.			

VM_STD_UNDER_VOLTS		Range applied the standard under-voltage threshold	
Units	V		
Range of [MIN]	0 to 1150		
Range of [MAX]	0 to 1150		
Definition	VM_STD_UNDER_VOLTS[MAX] = VM_DC_VOLTAGE_SET / 1.1		
	VM_STD_UNDER_VOLTS[MIN] is voltage rating dependent. See Table 10-4		

VM_SUPPLY_LOSS_LEVEL		Range applied to the supply loss threshold	
Units	V		
Range of [MIN]	0 to 1150		
Range of [MAX]	0 to 1150		
Definition	VM_SUPPLY_LOSS_LEVEL[MAX] = VM_DC_VOLTAGE_SET[MAX]		
	VM_SUPPLY_LOSS_LEVEL[MIN] is drive voltage rating dependent. See Table 10-4		

VM_SWITCHING_FREQUENCY		Range applied to the maximum switching frequency parameters	
Units	User units		
Range of [MIN]	0		
Range of [MAX]	0 to 6		
Definition	VM_SWITCHING_FREQUENCY[MAX] = Power stage dependent		
	VM_SWITCHING_FREQUENCY[MIN] = 0 for motor control modes, or 1 for Regen mode (subject to the maximum)		

VM_TORQUE_CURRENT		Range applied to torque and torque producing current parameters (where this is used in Regen mode it refers to the active current)	
Units	%		
Range of [MIN]	-1000.0 to 0.0		
Range of [MAX]	0.0 to 1000.0		
Definition	<b>Select Motor 2 Parameters (11.045)</b>		<b>VM_TORQUE_CURRENT [MAX]</b>
	0		VM_MOTOR1_CURRENT_LIMIT[MAX]
	1		VM_MOTOR2_CURRENT_LIMIT[MAX]
	VM_TORQUE_CURRENT[MIN] = -VM_TORQUE_CURRENT[MAX]		

<b>VM_TORQUE_CURRENT_UNIPOLAR</b>		Unipolar version of VM_TORQUE_CURRENT
<b>Units</b>	%	
<b>Range of [MIN]</b>	0.0	
<b>Range of [MAX]</b>	0.0 to 1000.0	
<b>Definition</b>	<p>VM_TORQUE_CURRENT_UNIPOLAR[MAX] = VM_TORQUE_CURRENT[MAX]</p> <p>VM_TORQUE_CURRENT_UNIPOLAR[MIN] = 0.0</p> <p><i>User Current Maximum Scaling</i> (04.024) defines the variable maximum/minimums VM_USER_CURRENT and VM_USER_CURRENT_HIGH_RES which are applied to <i>Percentage Load</i> (04.020), <i>Torque Reference</i> (04.008) and <i>Torque Offset</i> (04.009). This is useful when routing these parameters to an analog output as it allows the full scale output value to be defined by the user. This maximum is subject to a limit of MOTOR1_CURRENT_LIMIT or MOTOR2_CURRENT_LIMIT depending on which motor map is currently active.</p> <p>The maximum value (VM_TORQUE_CURRENT_UNIPOLAR [MAX]) varies between drive sizes with default parameters loaded. For some drive sizes the default value may be reduced below the value given by the parameter range limiting.</p>	

<b>VM_USER_CURRENT</b>		Range applied to torque reference and percentage load parameters with one decimal place
<b>Units</b>	%	
<b>Range of [MIN]</b>	-1000.0 to 0.0	
<b>Range of [MAX]</b>	0.0 to 1000.0	
<b>Definition</b>	<p>VM_USER_CURRENT[MAX] = <i>User Current Maximum Scaling</i> (04.024)</p> <p>VM_USER_CURRENT[MIN] = -VM_USER_CURRENT[MAX]</p> <p><i>User Current Maximum Scaling</i> (04.024) defines the variable maximum/minimums VM_USER_CURRENT and VM_USER_CURRENT_HIGH_RES which are applied to <i>Percentage Load</i> (04.020), <i>Torque Reference</i> (04.008) and <i>Torque Offset</i> (04.009). This is useful when routing these parameters to an analog output as it allows the full scale output value to be defined by the user. This maximum is subject to a limit of MOTOR1_CURRENT_LIMIT or MOTOR2_CURRENT_LIMIT depending on which motor map is currently active.</p> <p>The maximum value (VM_TORQUE_CURRENT_UNIPOLAR [MAX]) varies between drive sizes with default parameters loaded. For some drive sizes the default value may be reduced below the value given by the parameter range limiting.</p>	

<b>VM_USER_CURRENT_HIGH_RES</b>		Range applied to torque reference and percentage load parameters with two decimal places
<b>Units</b>	%	
<b>Range of [MIN]</b>	-1000.00 to 0.00	
<b>Range of [MAX]</b>	0.00 to 1000.00	
<b>Definition</b>	<p>VM_USER_CURRENT_HIGH_RES[MAX] = <i>User Current Maximum Scaling</i> (04.024) with an additional decimal place</p> <p>VM_USER_CURRENT_HIGH_RES[MIN] = -VM_USER_CURRENT_HIGH_RES[MAX]</p> <p><i>User Current Maximum Scaling</i> (04.024) defines the variable maximum/minimums VM_USER_CURRENT and VM_USER_CURRENT_HIGH_RES which are applied to <i>Percentage Load</i> (04.020), <i>Torque Reference</i> (04.008) and <i>Torque Offset</i> (04.009). This is useful when routing these parameters to an analog output as it allows the full scale output value to be defined by the user. This maximum is subject to a limit of MOTOR1_CURRENT_LIMIT or MOTOR2_CURRENT_LIMIT depending on which motor map is currently active.</p> <p>The maximum value (VM_TORQUE_CURRENT_UNIPOLAR [MAX]) varies between drive sizes with default parameters loaded. For some drive sizes the default value may be reduced below the value given by the parameter range limiting.</p>	

**Table 10-4 Voltage ratings dependant values**

Variable min/max	Voltage level (V)			
	200 V	400 V	575 V	690 V
VM_DC_VOLTAGE_SET[MAX]	400	800	955	1150
VM_DC_VOLTAGE[MAX]	415	830	990	1190
VM_AC_VOLTAGE_SET[MAX]	265	530	635	765
VM_AC_VOLTAGE[MAX]	325	650	780	930
VM_STD_UNDER_VOLTS[MIN]	175	330	435	435
VM_SUPPLY_LOSS_LEVEL[MIN]	205	410	540	540
VM_HIGH_DC_VOLTAGE	1500	1500	1500	1500



## 10.2 Menu 1: Frequency / speed reference

Figure 10-1 Menu 1 logic diagram

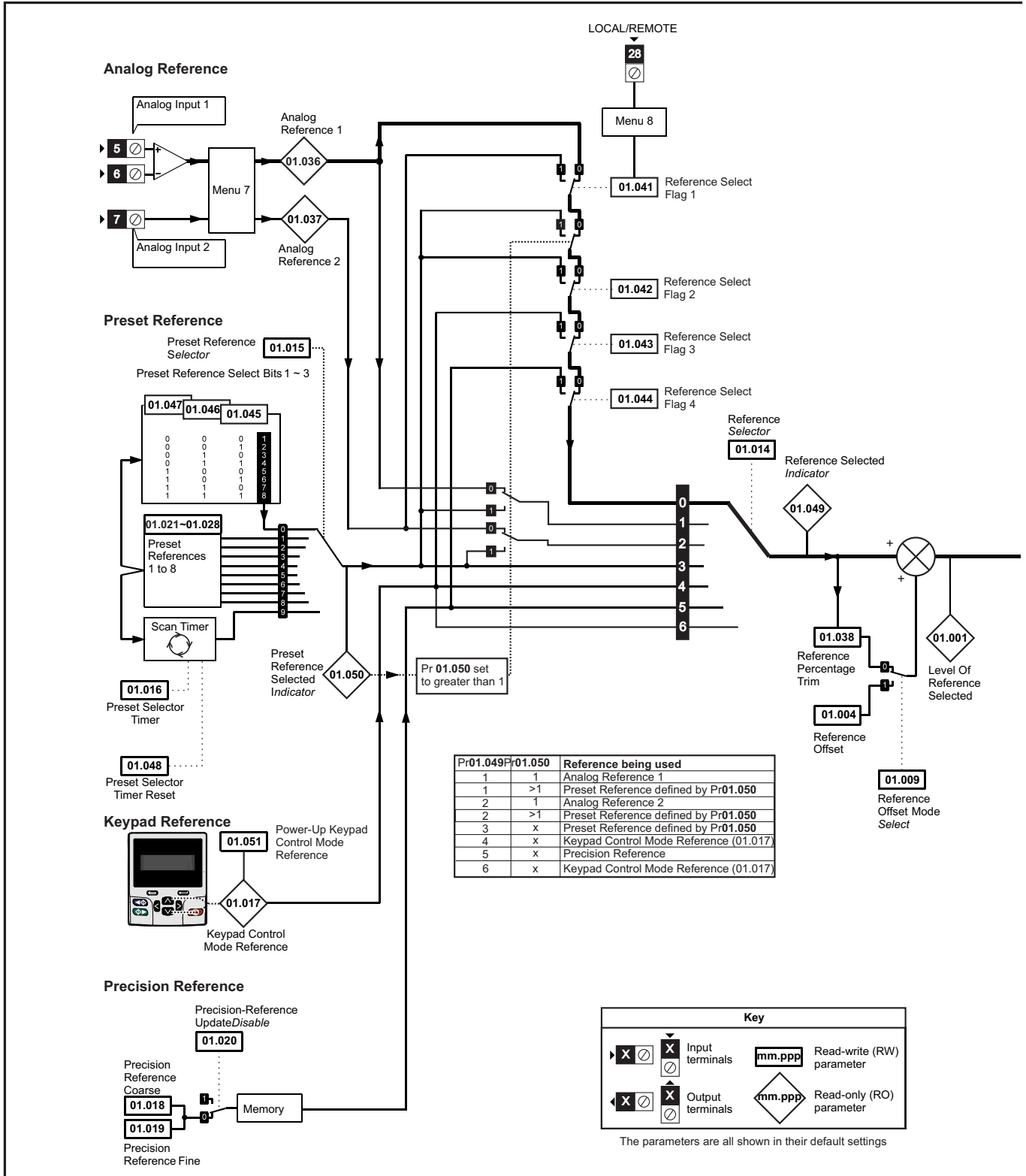

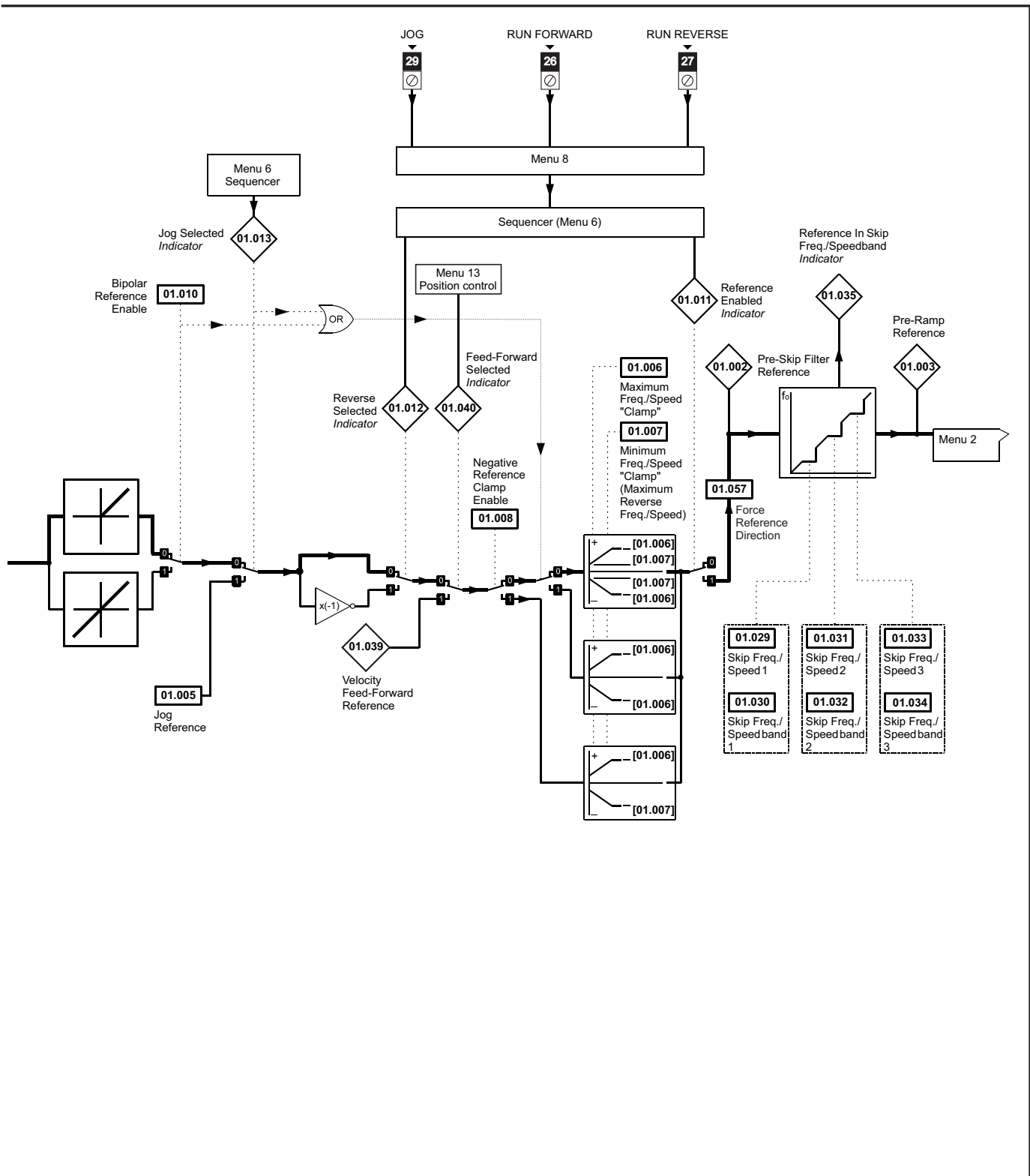

Parameter	Range(⌘)		Default(⇨)			Type								
	OL	RFC-A / S	OL	RFC-A	RFC-S									
01.001	Reference Selected	VM_SPEED_FREQ_REF Hz	VM_SPEED_FREQ_REF rpm							RO	Num	ND	NC	PT
01.002	Pre-Skip Filter Reference	VM_SPEED_FREQ_REF Hz	VM_SPEED_FREQ_REF rpm							RO	Num	ND	NC	PT
01.003	Pre-Ramp Reference	VM_SPEED_FREQ_REF Hz	VM_SPEED_FREQ_REF rpm							RO	Num	ND	NC	PT
01.004	Reference Offset	VM_SPEED_FREQ_REF Hz	VM_SPEED_FREQ_REF rpm							RW	Num			US
01.005	Jog Reference	0.0 - 400.0 Hz	0.0 - 4000.0 rpm							RW	Num			US
01.006	Maximum Reference Clamp	0.0 to VM_POSITIVE_REF_CLAMP1 Hz	0.0 to VM_POSITIVE_REF_CLAMP1 rpm	50Hz: 50.0 60Hz: 60.0	50Hz: 1500.0 60Hz: 1800.0					RW	Num			US
01.007	Minimum Reference Clamp	VM_NEGATIVE_REF_CLAMP1 to 0.0	VM_NEGATIVE_REF_CLAMP1 to 0.0			0.0				RW	Num			US
01.008	Negative Reference Clamp Enable	Off (0) or On (1)		Off (0)						RW	Bit			US
01.009	Reference Offset Select	Off (0) or On (1)		Off (0)						RW	Bit			US
01.010	Bipolar Reference Enable	Off (0) or On (1)		Off (0)						RW	Bit			US
01.011	Reference On	Off (0) or On (1)								RO	Bit	ND	NC	PT
01.012	Reverse Select	Off (0) or On (1)								RO	Bit	ND	NC	PT
01.013	Jog Select	Off (0) or On (1)								RO	Bit	ND	NC	PT
01.014	Reference Selector	A1 A2 (0), A1 Preset (1), A2 Preset (2) Preset (3), Keypad (4), Precision (5) Keypad Ref (6)		A1 A2 (0)						RW	Txt	ND		US
01.015	Preset Selector	0 to 9		0						RW	Num			US
01.016	Preset Selector Time	0.0 to 400.0 s		10.0 s						RW	Num			US
01.017	Keypad Control Mode Reference	VM_SPEED_FREQ_KEYPAD_REF		0.0						RO	Num		NC	PT
01.018	Precision Reference Coarse	VM_SPEED_FREQ_REFS		0.0						RW	Num			US
01.019	Precision Reference Fine	0.000 to 0.099 Hz	0.000 to 0.099 rpm	0.000 Hz	0.000 rpm					RW	Num			us
01.020	Precision Reference Update Disable	Off (0) or On (1)		Off (0)						RW	Bit		NC	
01.021	Preset Reference 1	VM_SPEED_FREQ_REF		0.0						RW	Num			US
01.022	Preset Reference 2	VM_SPEED_FREQ_REF		0.0						RW	Num			US
01.023	Preset Reference 3	VM_SPEED_FREQ_REF		0.0						RW	Num			US
01.024	Preset Reference 4	VM_SPEED_FREQ_REF		0.0						RW	Num			US
01.025	Preset Reference 5	VM_SPEED_FREQ_REF		0.0						RW	Num			US
01.026	Preset Reference 6	VM_SPEED_FREQ_REF		0.0						RW	Num			US
01.027	Preset Reference 7	VM_SPEED_FREQ_REF		0.0						RW	Num			US
01.028	Preset Reference 8	VM_SPEED_FREQ_REF		0.0						RW	Num			US
01.029	Skip Reference 1	0.0 to 550.0 Hz	0 to 33,000 rpm	0.0	0					RW	Num			US
01.030	Skip Reference Band 1	0.0 to 25.0 Hz	0 to 250 rpm	0.0	0					RW	Num			US
01.031	Skip Reference 2	0.0 to 550.0 Hz	0 to 33,000 rpm	0.0	0					RW	Num			US
01.032	Skip Reference Band 2	0.0 to 25.0 Hz	0 to 250 rpm	0.0	0					RW	Num			US
01.033	Skip Reference 3	0.0 to 550.0 Hz	0 to 33,000 rpm	0.0	0					RW	Num			US
01.034	Skip Reference Band 3	0.0 to 25.0 Hz	0 to 250 rpm	0.0	0					RW	Num			US
01.035	Reference In Rejection Zone	Off (0) or On (1)		Off (0) or On (1)						RO	Bit	ND	NC	PT
01.036	Analog Reference 1	VM_SPEED_FREQ_USER_REFS Hz	VM_SPEED_FREQ_USER_REFS rpm	0.0						RO	Num		NC	
01.037	Analog Reference 2	VM_SPEED_FREQ_USER_REFS Hz	VM_SPEED_FREQ_USER_REFS rpm	0.0						RO	Num		NC	
01.038	Percentage Trim	±100.00 %		0.00 %						RW	Num		NC	
01.039	Speed Feed-forwards	VM_SPEED_FREQ_REF								RO	Num	ND	NC	PT
01.040	Speed Feed-forwards Select	Off (0) or On (1)								RO	Bit	ND	NC	PT
01.041	Reference Select Flag 1	Off (0) or On (1)		Off (0)						RW	Bit	ND	NC	PT
01.042	Reference Select Flag 2	Off (0) or On (1)		Off (0)						RW	Bit	ND	NC	PT
01.043	Reference Select Flag 3	Off (0) or On (1)		Off (0)						RW	Bit	ND	NC	PT
01.044	Reference Select Flag 4	Off (0) or On (1)		Off (0)						RW	Bit	ND	NC	PT
01.045	Preset Select Flag 1	Off (0) or On (1)		Off (0)						RW	Bit	ND	NC	PT
01.046	Preset Select Flag 2	Off (0) or On (1)		Off (0)						RW	Bit	ND	NC	PT
01.047	Preset Select Flag 3	Off (0) or On (1)		Off (0)						RW	Bit	ND	NC	PT
01.048	Preset Selector Timer Reset	Off (0) or On (1)		Off (0)						RW	Bit	ND	NC	PT
01.049	Reference Selected Indicator	1 to 6								RO	Num	ND	NC	PT
01.050	Preset Selected Indicator	1 to 8								RO	Num	ND	NC	PT
01.051	Power-up Keypad Control Mode Reference	Reset (0), Last (1), Preset (2)		Reset (0)						RW	Txt			US
01.057	Force Reference Direction	None (0), Forward (1), Reverse (2)		None (0)						RW	Num			

RW	Read / Write	RO	Read only	Num	Number parameter	Bit	Bit parameter	Txt	Text string	Bin	Binary parameter	FI	Filtered
ND	No default value	NC	Not copied	PT	Protected parameter	RA	Rating dependent	US	User save	PS	Power-down save	DE	Destination



## 10.3 Menu 2: Ramps

Figure 10-2 Menu 2 logic diagram

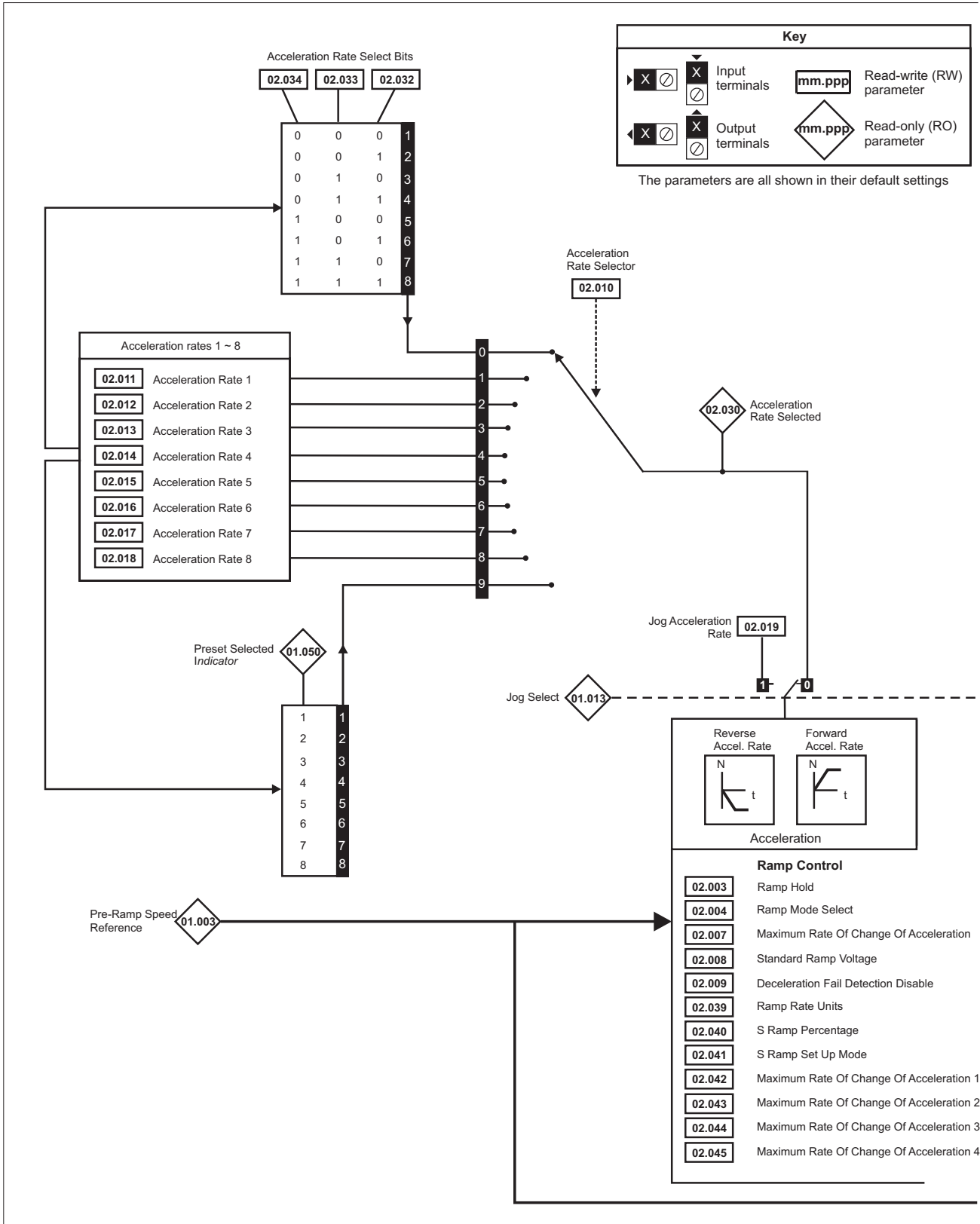

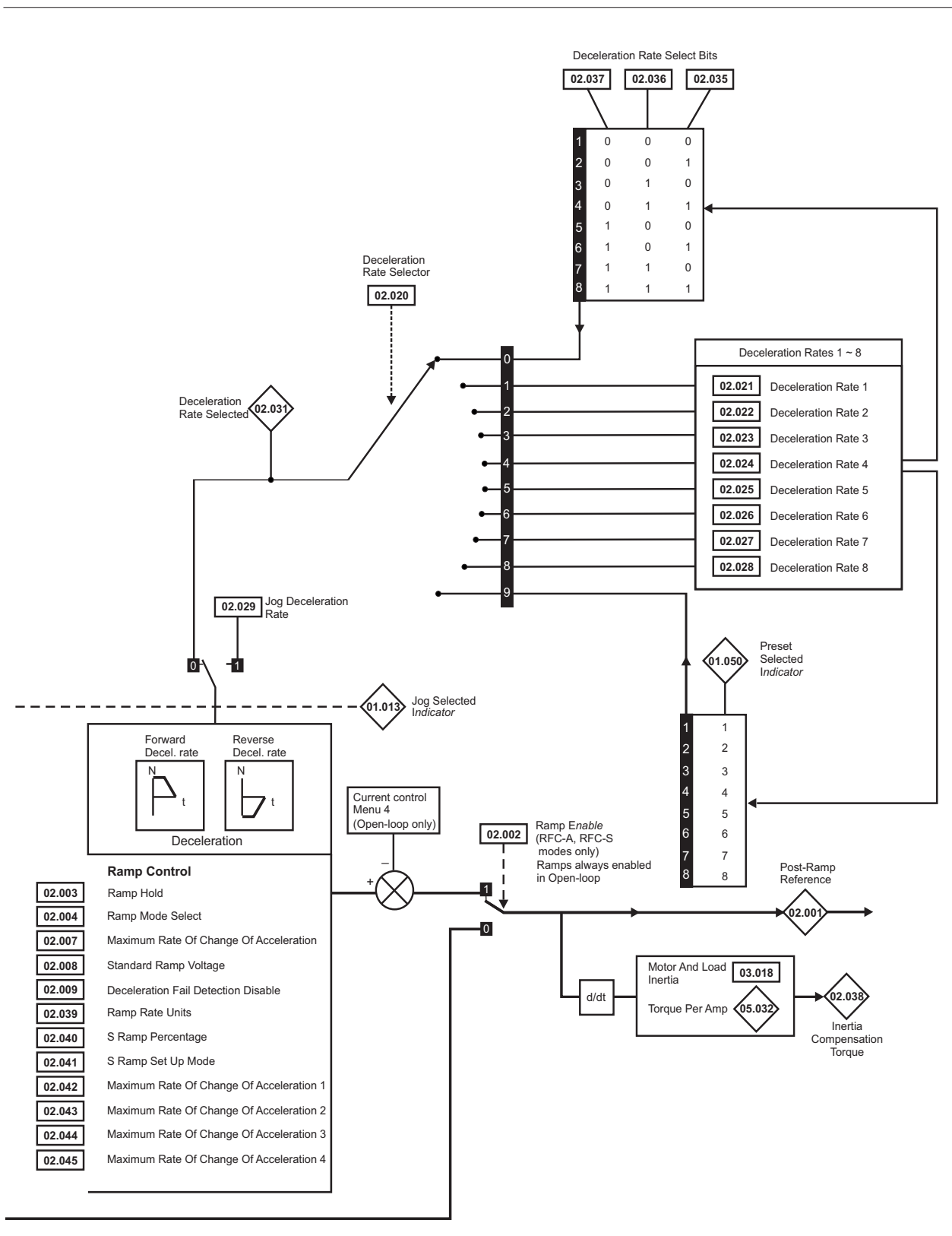

Parameter		Range(↕)		Default(⇨)			Type					
		OL	RFC-A / S	OL	RFC-A	RFC-S	RO	Num	ND	NC	PT	
02.001	Post Ramp Reference	VM_SPEED_FREQ_REF Hz	VM_SPEED_FREQ_REF rpm				RO	Num	ND	NC	PT	
02.002	Ramp Enable		Off (0) or On (1)		On (1)		RW	Bit				US
02.003	Ramp Hold		Off (0) or On (1)		Off (0)		RW	Bit				US
02.004	Ramp Mode	Fast (0), Standard (1), Std boost (2)	Fast (0), Standard (1)		Standard (1)		RW	Txt				US
02.005	Disable Ramp Output		Off (0) or On (1)		Off (0)		RW	Bit				US
02.006	S Ramp Enable		Off (0) or On (1)		Off (0)		RW	Bit				US
02.007	Maximum Rate Of Change Of Acceleration	0.0 to 300.0 s <sup>2</sup> /100 Hz	0.000 to 100.000 s <sup>2</sup> /1000 rpm	3.1	1.500		RW	Num				US
02.008	Standard Ramp Voltage	0 to VM_DC_VOLTAGE_SET V		200 V drive: 375 V 400 V drive 50 Hz: 750 V 400 V drive 60 Hz: 775 V 575 V drive: 895 V 690 V: 1075 V			RW	Num		RA		US
02.009	Deceleration Fail Detection Disable	Off (0) or On (1)	Off (0) or On (1)		Off (0)		RW	Bit				US
02.010	Acceleration Rate Selector	0 to 9	0 to 9		0		RW	Num				US
02.011	Acceleration Rate 1	0.0 to VM_ACCEL_RATE s/100 Hz	0.000 to VM_ACCEL_RATE s/1000 rpm	5.0 s	2.000 s		RW	Num				US
02.012	Acceleration Rate 2	0.0 to VM_ACCEL_RATE s/100 Hz	0.000 to VM_ACCEL_RATE s/1000 rpm	5.0 s	2.000 s		RW	Num				US
02.013	Acceleration Rate 3	0.0 to VM_ACCEL_RATE s/100 Hz	0.000 to VM_ACCEL_RATE s/1000 rpm	5.0 s	2.000 s		RW	Num				US
02.014	Acceleration Rate 4	0.0 to VM_ACCEL_RATE s/100 Hz	0.000 to VM_ACCEL_RATE s/1000 rpm	5.0 s	2.000 s		RW	Num				US
02.015	Acceleration Rate 5	0.0 to VM_ACCEL_RATE s/100 Hz	0.000 to VM_ACCEL_RATE s/1000 rpm	5.0 s	2.000 s		RW	Num				US
02.016	Acceleration Rate 6	0.0 to VM_ACCEL_RATE s/100 Hz	0.000 to VM_ACCEL_RATE s/1000 rpm	5.0 s	2.000 s		RW	Num				US
02.017	Acceleration Rate 7	0.0 to VM_ACCEL_RATE s/100 Hz	0.000 to VM_ACCEL_RATE s/1000 rpm	5.0 s	2.000 s		RW	Num				US
02.018	Acceleration Rate 8	0.0 to VM_ACCEL_RATE s/100 Hz	0.000 to VM_ACCEL_RATE s/1000 rpm	5.0 s	2.000 s		RW	Num				US
02.019	Jog Acceleration Rate	0.0 to VM_ACCEL_RATE s/100 Hz	0.000 to VM_ACCEL_RATE s/1000 rpm	0.2 s	0.000 s		RW	Num				US
02.020	Deceleration Rate Selector	0 to 9		0			RW	Num				US
02.021	Deceleration Rate 1	0.0 to VM_ACCEL_RATE s/100 Hz	0.000 to VM_ACCEL_RATE s/1000 rpm	10.0 s	2.000 s		RW	Num				US
02.022	Deceleration Rate 2	0.0 to VM_ACCEL_RATE s/100 Hz	0.000 to VM_ACCEL_RATE s/1000 rpm	10.0 s	2.000 s		RW	Num				US
02.023	Deceleration Rate 3	0.0 to VM_ACCEL_RATE s/100 Hz	0.000 to VM_ACCEL_RATE s/1000 rpm	10.0 s	2.000 s		RW	Num				US
02.024	Deceleration Rate 4	0.0 to VM_ACCEL_RATE s/100 Hz	0.000 to VM_ACCEL_RATE s/1000 rpm	10.0 s	2.000 s		RW	Num				US
02.025	Deceleration Rate 5	0.0 to VM_ACCEL_RATE s/100 Hz	0.000 to VM_ACCEL_RATE s/1000 rpm	10.0 s	2.000 s		RW	Num				US
02.026	Deceleration Rate 6	0.0 to VM_ACCEL_RATE s/100 Hz	0.000 to VM_ACCEL_RATE s/1000 rpm	10.0 s	2.000 s		RW	Num				US
02.027	Deceleration Rate 7	0.0 to VM_ACCEL_RATE s/100 Hz	0.000 to VM_ACCEL_RATE s/1000 rpm	10.0 s	2.000 s		RW	Num				US
02.028	Deceleration Rate 8	0.0 to VM_ACCEL_RATE s/100 Hz	0.000 to VM_ACCEL_RATE s/1000 rpm	10.0 s	2.000 s		RW	Num				US
02.029	Jog Deceleration Rate	0.0 to VM_ACCEL_RATE s/100 Hz	0.000 to VM_ACCEL_RATE s/1000 rpm	0.2 s	0.000 s		RW	Num				US
02.030	Acceleration Rate Selected	0 to 8					RO	Num	ND	NC	PT	
02.031	Deceleration Rate Selected	0 to 8					RO	Num	ND	NC	PT	
02.032	Acceleration Rate Select Bit 0	Off (0) or On (1)		Off (0)			RW	Bit		NC		
02.033	Acceleration Rate Select Bit 1	Off (0) or On (1)		Off (0)			RW	Bit		NC		
02.034	Acceleration Rate Select Bit 2	Off (0) or On (1)		Off (0)			RW	Bit		NC		
02.035	Deceleration Rate Select Bit 0	Off (0) or On (1)		Off (0)			RW	Bit		NC		
02.036	Deceleration Rate Select Bit 1	Off (0) or On (1)		Off (0)			RW	Bit		NC		
02.037	Deceleration Rate Select Bit 2	Off (0) or On (1)		Off (0)			RW	Bit		NC		
02.038	Inertia Compensation Torque	±1000.0 %					RO	Num	ND	NC	PT	
02.039	Ramp Rate Units	Off = 100 Hz (0) or On = Maximum frequency (1)	Off = 1000 rpm or 1000 mm/s (0) or On = Maximum speed (1)	Off = 100 Hz (0)	Off = 1000 rpm or 1000 mm/s (0)		RW	Bit				US
02.040	S Ramp Percentage	0.0 to 50.0 %		0.0 %			RW	Num				US
02.041	S Ramp Set-up Mode	Single (0), Percentage (1), Independent (2)		Single (0)			RW	Txt				US
02.042	Maximum Rate Of Change Of Acceleration 1	0.0 to 300.0 s <sup>2</sup> /100 Hz	0.000 to 100.000 s <sup>2</sup> / 1000 rpm	0.0 s <sup>2</sup> /100 Hz	0.000 s <sup>2</sup> / 1000 rpm		RW	Num				US
02.043	Maximum Rate Of Change Of Acceleration 2	0.0 to 300.0 s <sup>2</sup> /100 Hz	0.000 to 100.000 s <sup>2</sup> / 1000 rpm	0.0 s <sup>2</sup> /100 Hz	0.000 s <sup>2</sup> / 1000 rpm		RW	Num				US
02.044	Maximum Rate Of Change Of Acceleration 3	0.0 to 300.0 s <sup>2</sup> /100 Hz	0.000 to 100.000 s <sup>2</sup> / 1000 rpm	0.0 s <sup>2</sup> /100 Hz	0.000 s <sup>2</sup> / 1000 rpm		RW	Num				US
02.045	Maximum Rate Of Change Of Acceleration 4	0.0 to 300.0 s <sup>2</sup> /100 Hz	0.000 to 100.000 s <sup>2</sup> / 1000 rpm	0.0 s <sup>2</sup> /100 Hz	0.000 s <sup>2</sup> / 1000 rpm		RW	Num				US

RW	Read / Write	RO	Read only	Num	Number parameter	Bit	Bit parameter	Txt	Text string	Bin	Binary parameter	FI	Filtered
ND	No default value	NC	Not copied	PT	Protected parameter	RA	Rating dependent	US	User save	PS	Power-down save	DE	Destination

## 10.4 Menu 3: Speed feedback and speed control

Figure 10-3 Menu 3 Open-loop logic diagram

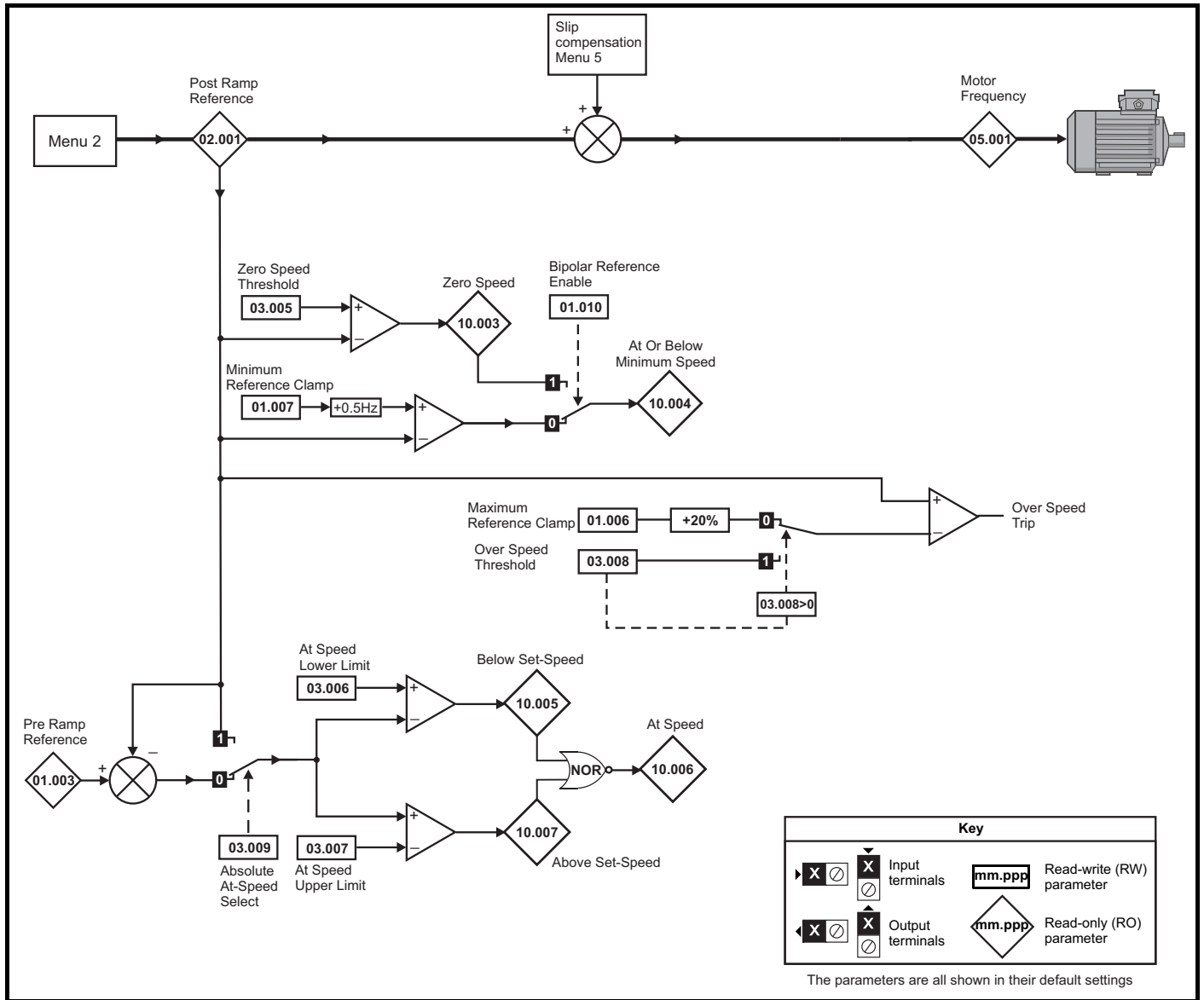
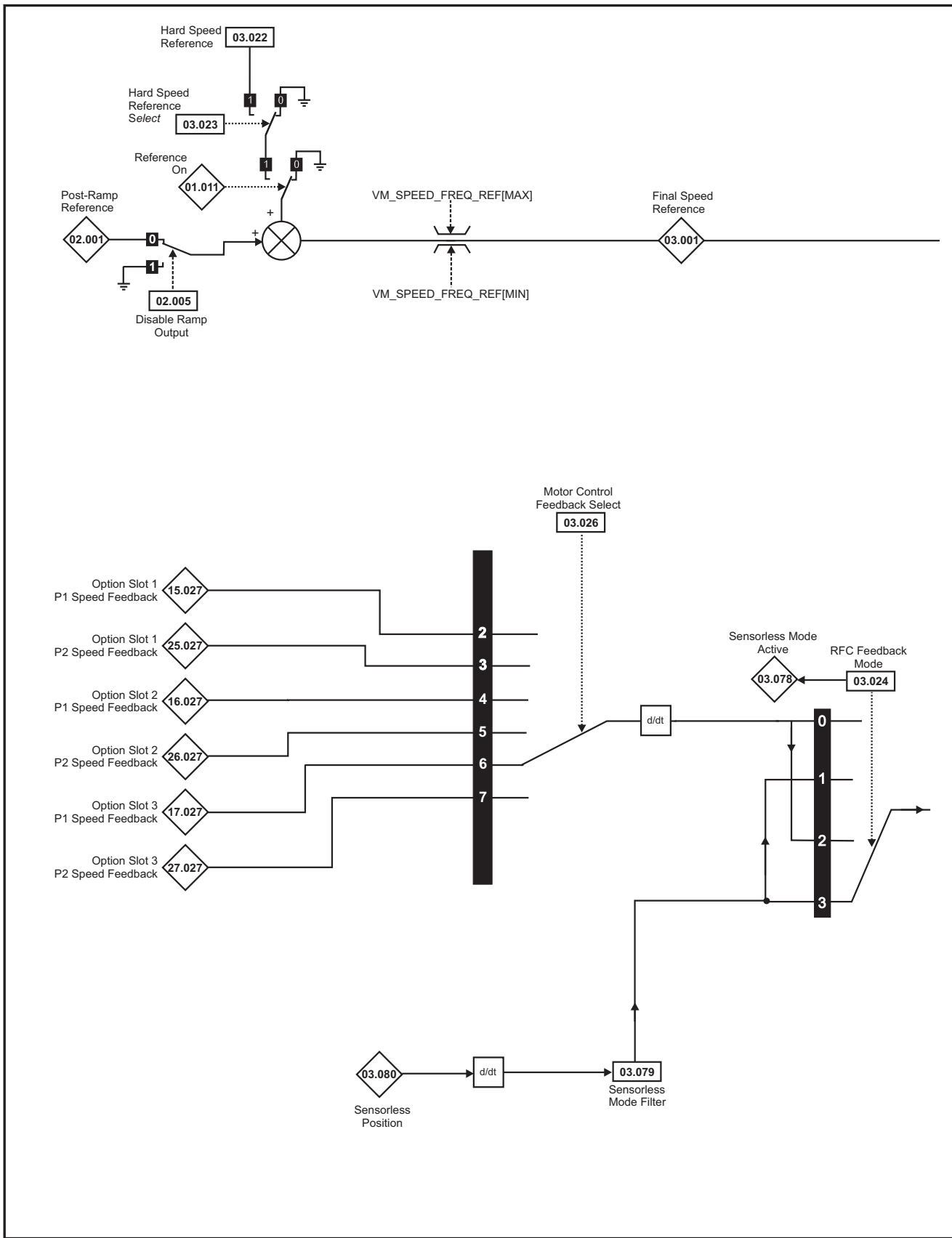
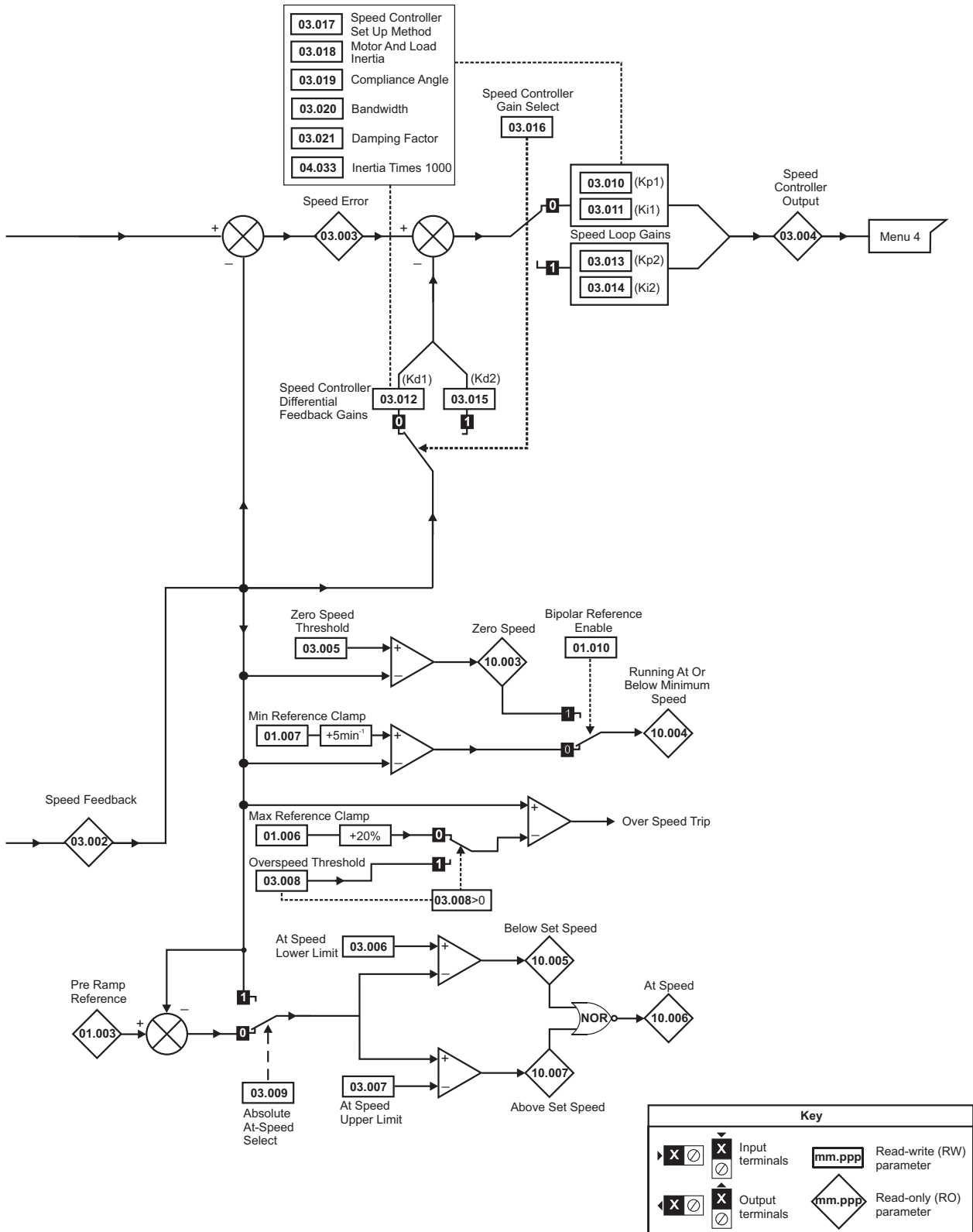

Figure 10-4 Menu 3 RFC-A, RFC-S logic diagram



**NOTE**  
 \* Automatic change over if the relevant 'bit' of *Position Feedback Initialized* (03.076) is 0.



Parameter	Range			Default			Type						
	OL	RFC-A	RFC-S	OL	RFC-A	RFC-S	RO	Num	ND	NC	PT	FI	
03.001	Final Speed Reference	VM_SPEED						RO	Num	ND	NC	PT	FI
03.002	Speed Feedback	VM_SPEED						RO	Num	ND	NC	PT	FI
03.003	Speed Error	VM_SPEED						RO	Num	ND	NC	PT	FI
03.004	Speed Controller Output	VM_TORQUE_CURRENT %						RO	Num	ND	NC	PT	FI
03.005	Zero Speed Threshold	0.0 to 20.0 Hz	0 to 200 rpm		1.0 Hz	5 rpm		RW	Num				US
03.006	At Speed Lower Limit	0.0 to 550.0 Hz	0 to 33000 rpm		1.0 Hz	5 rpm		RW	Num				US
03.007	At Speed Upper Limit	0.0 to 550.0 Hz	0 to 33000 rpm		1.0 Hz	5 rpm		RW	Num				US
03.008	Over Speed Threshold	0.0 to 550.0 Hz	0 to 40000 rpm		0.0 Hz	0 rpm		RW	Num				US
03.009	Absolute At Speed Select	Off (0) or On (1)			Off (0)			RW	Bit				US
03.010	Speed Controller Proportional Gain Kp1	0.0000 to 200.0000 s/rad			0.0300 s/rad		0.0100 s/rad	RW	Num				US
03.011	Speed Controller Integral Gain Ki1	0.00 to 655.35 s <sup>2</sup> /rad			0.10 s <sup>2</sup> /rad		0.05 s <sup>2</sup> /rad	RW	Num				US
03.012	Speed Controller Differential Feedback Gain Kd1	0.00000 to 0.65535 1/rad			0.00000 1/rad			RW	Num				US
03.013	Speed Controller Proportional Gain Kp2	0.0000 to 200.0000 s/rad			0.0300 s/rad		0.0100 s/rad	RW	Num				US
03.014	Speed Controller Integral Gain Ki2	0.00 to 655.35 s <sup>2</sup> /rad			0.10 s <sup>2</sup> /rad		0.05 s <sup>2</sup> /rad	RW	Num				US
03.015	Speed Controller Differential Feedback Gain Kd2	0.00000 to 0.65535 1/rad			0.00000 1/rad			RW	Num				US
03.016	Speed Controller Gain Select	Off (0) or On (1)			Off (0)			RW	Bit				US
03.017	Speed Controller Set-up Method	Disabled (0), Bandwidth (1), Comp Angle (2), Kp Gain Times 16 (3), Low Performance (4), Std Performance (5), High Performance (6), First Order (7)			Disabled (0)			RW	Txt				US
03.018	Motor And Load Inertia	0.00000 to 1000.00000 kgm <sup>2</sup>			0.00000 kgm <sup>2</sup>			RW	Num				US
03.019	Compliance Angle	0.0 to 360.0 °			4.0 °			RW	Num				US
03.020	Bandwidth	5 to 1000 Hz			10 Hz			RW	Num				US
03.021	Damping Factor	0.0 to 10.0			1.0			RW	Num				US
03.022	Hard Speed Reference	VM_SPEED_ FREQ_REF		VM_SPEED	0.0			RW	Num				US
03.023	Hard Speed Reference Select	Off (0) or On (1)			Off (0)			RW	Bit				US
03.024	RFC Feedback Mode	Feedback (0), Sensorless (1), Feedback NoMax (2), Sensorless NoMax (3)			Sensorless NoMax (3)		RW	Txt					US
03.026	Motor Control Feedback Select	P1 Slot 1 (2), P2 Slot 1 (3), P1 Slot 2 (4), P2 Slot 2 (5), P1 Slot 3 (6), P2 Slot 3 (7)			P1 Slot 3 (6)		RW	Txt					US
03.075	Initialise Position Feedback	Off (0) or On (1)			Off (0)			RW	Bit		NC		
03.076	Position Feedback Initialized	0000000000 to 1111111111			0000000000			RO	Bin		NC	PT	
03.078	Sensorless Mode Active	Off (0) or On (1)						RO	Bit	ND	NC	PT	
03.079	Sensorless Mode Filter	4 (0), 8 (1), 16 (2), 32 (3), 64 (4) ms			4 (0) ms			RW	Txt				US
03.080	Sensorless Position	-2147483648 to 2147483647						RO	Num	ND	NC	PT	

RW	Read / Write	RO	Read only	Num	Number parameter	Bit	Bit parameter	Txt	Text string	Bin	Binary parameter	FI	Filtered
ND	No default value	NC	Not copied	PT	Protected parameter	RA	Rating dependent	US	User save	PS	Power-down save	DE	Destination

## 10.5 Menu 4: Torque and current control

Figure 10-5 Menu 4 Open loop logic diagram

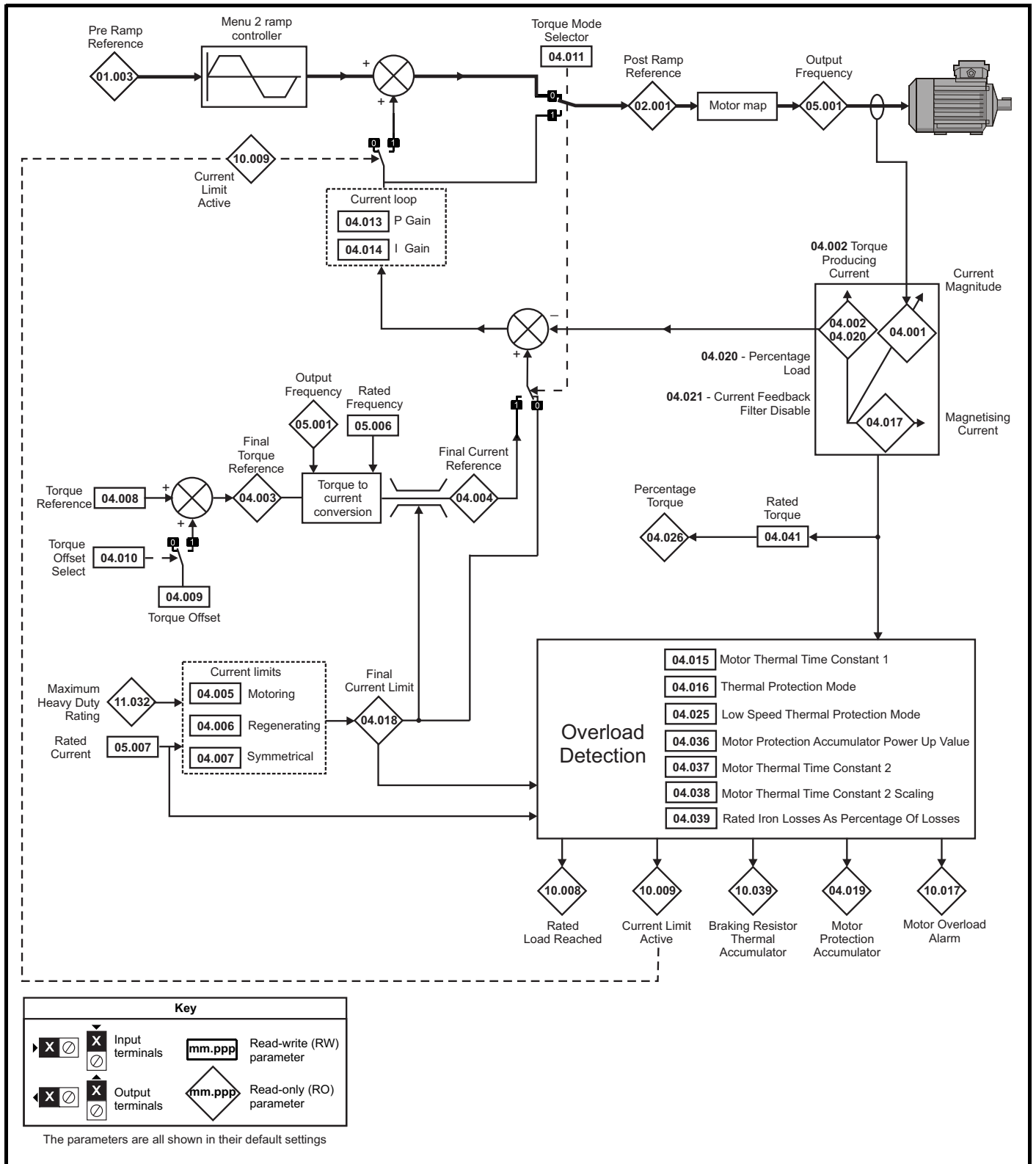
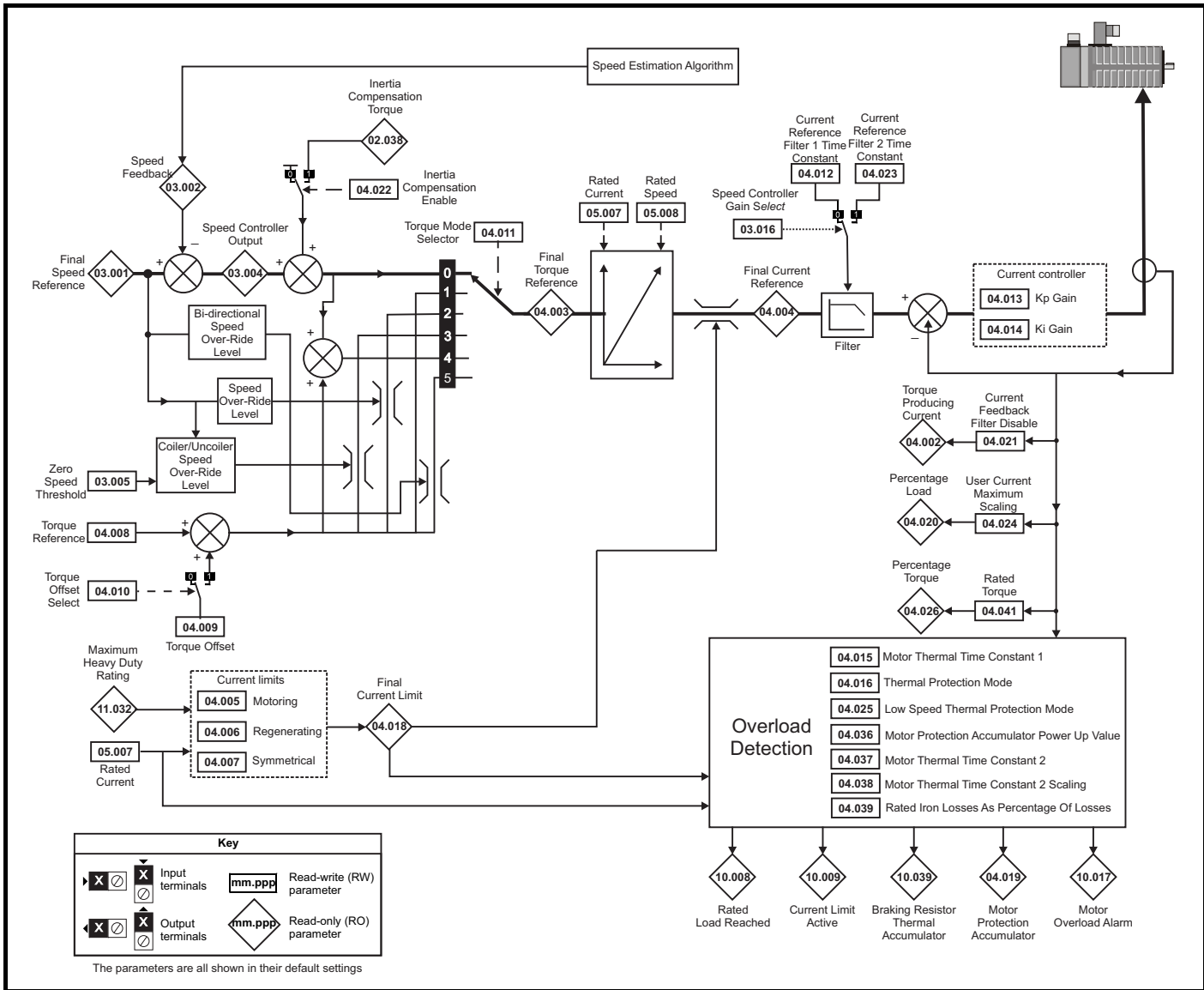



Figure 10-7 Menu 4 RFC-S logic diagram



Parameter	Range(⚡)		Default(⇄)			Type					
	OL	RFC-A / S	OL	RFC-A	RFC-S						
04.001	Current Magnitude	0.000 to VM_DRIVE_CURRENT_UNIPOLAR				RO	Num	ND	NC	PT	FI
04.002	Torque Producing Current / Iq	VM_DRIVE_CURRENT				RO	Num	ND	NC	PT	FI
04.003	Final Torque Reference	VM_TORQUE_CURRENT				RO	Num	ND	NC	PT	FI
04.004	Final Current Reference	VM_TORQUE_CURRENT				RO	Num	ND	NC	PT	FI
04.005	Motoring Current Limit	0.0 to VM_MOTOR1_CURRENT_LIMIT		165.0 % *	175.0 % **	RW	Num		RA		US
04.006	Regenerating Current Limit	0.0 to VM_MOTOR1_CURRENT_LIMIT		165.0 % *	175.0 % **	RW	Num		RA		US
04.007	Symmetrical Current Limit	0.0 to VM_MOTOR1_CURRENT_LIMIT		165.0 % *	175.0 % **	RW	Num		RA		US
04.008	Torque Reference	VM_USER_CURRENT_HIGH_RES		0.00 %		RW	Num				US
04.009	Torque Offset	VM_USER_CURRENT		0.0 %		RW	Num				US
04.010	Torque Offset Select	Off (0) or On (1)		Off (0)		RW	Bit				US
04.011	Torque Mode Selector	0 to 1	0 to 5	0		RW	Num				US
04.012	Current Reference Filter 1 Time Constant		0.0 to 25.0 ms		1.0 ms   2.0ms	RW	Num				US
04.013	Current Controller Kp Gain	0 to 30000		20	150	RW	Num				US
04.014	Current Controller Ki Gain	0 to 30000		40	2000	RW	Num				US
04.015	Motor Thermal Time Constant 1	1.0 to 3000.0 s		89.0 s		RW	Num				US
04.016	Thermal Protection Mode	00 to 11		00		RW	Bin				US
04.017	Magnetising Current / Id	VM_DRIVE_CURRENT				RO	Num	ND	NC	PT	FI
04.018	Final Current Limit	VM_TORQUE_CURRENT				RO	Num	ND	NC	PT	
04.019	Motor Protection Accumulator	0.0 to 100.0 %				RO	Num	ND	NC	PT	PS
04.020	Percentage Load	VM_USER_CURRENT				RO	Num	ND	NC	PT	FI
04.021	Current Feedback Filter Disable	Off (0) or On (1)		Off (0)		RW	Bit				US
04.022	Inertia Compensation Enable		Off (0) or On (1)		Off (0)	RW	Bit				US
04.023	Current Reference Filter 2 Time Constant		0.0 to 25.0 ms		1.0 ms	RW	Num				US
04.024	User Current Maximum Scaling	0.0 to VM_TORQUE_CURRENT_UNIPOLAR		165.0 % *	175.0 % **	RW	Num		RA		US
04.025	Low Speed Thermal Protection Mode	0 to 1		0		RW	Num				US
04.026	Percentage Torque	0.0 to VM_USER_CURRENT %				RO	Num	ND	NC	PT	FI
04.033	Inertia Times 1000		Off (0) or On (1)		Off (0)	RW	Bit				US
04.036	Motor Protection Accumulator Power-up Value	Power down (0), Zero (1), Real time (2)		Power down (0)		RW	Txt				US
04.037	Motor Thermal Time Constant 2	1.0 to 3000.0 s		89.0 s		RW	Num				US
04.038	Motor Thermal Time Constant 2 Scaling	0 to 100 %		0 %		RW	Num				US
04.039	Rated Iron Losses As Percentage Of Losses	0 to 100 %		0 %		RW	Num				US
04.041	Rated Torque	0.00 to 50000.00 Nm		0.00 Nm		RW	Num				US
04.049	Magnetising current limit		0.0 to 100.0 %		100.0 %	RW	Num				US

\* For size 9 and above the default is 141.9 %

\*\*For size 9 and above the default is 150.0 %

RW	Read / Write	RO	Read only	Num	Number parameter	Bit	Bit parameter	Txt	Text string	Bin	Binary parameter	FI	Filtered
ND	No default value	NC	Not copied	PT	Protected parameter	RA	Rating dependent	US	User save	PS	Power-down save	DE	Destination



Figure 10-9 Menu 5 RFC-A, RFC-S logic diagram

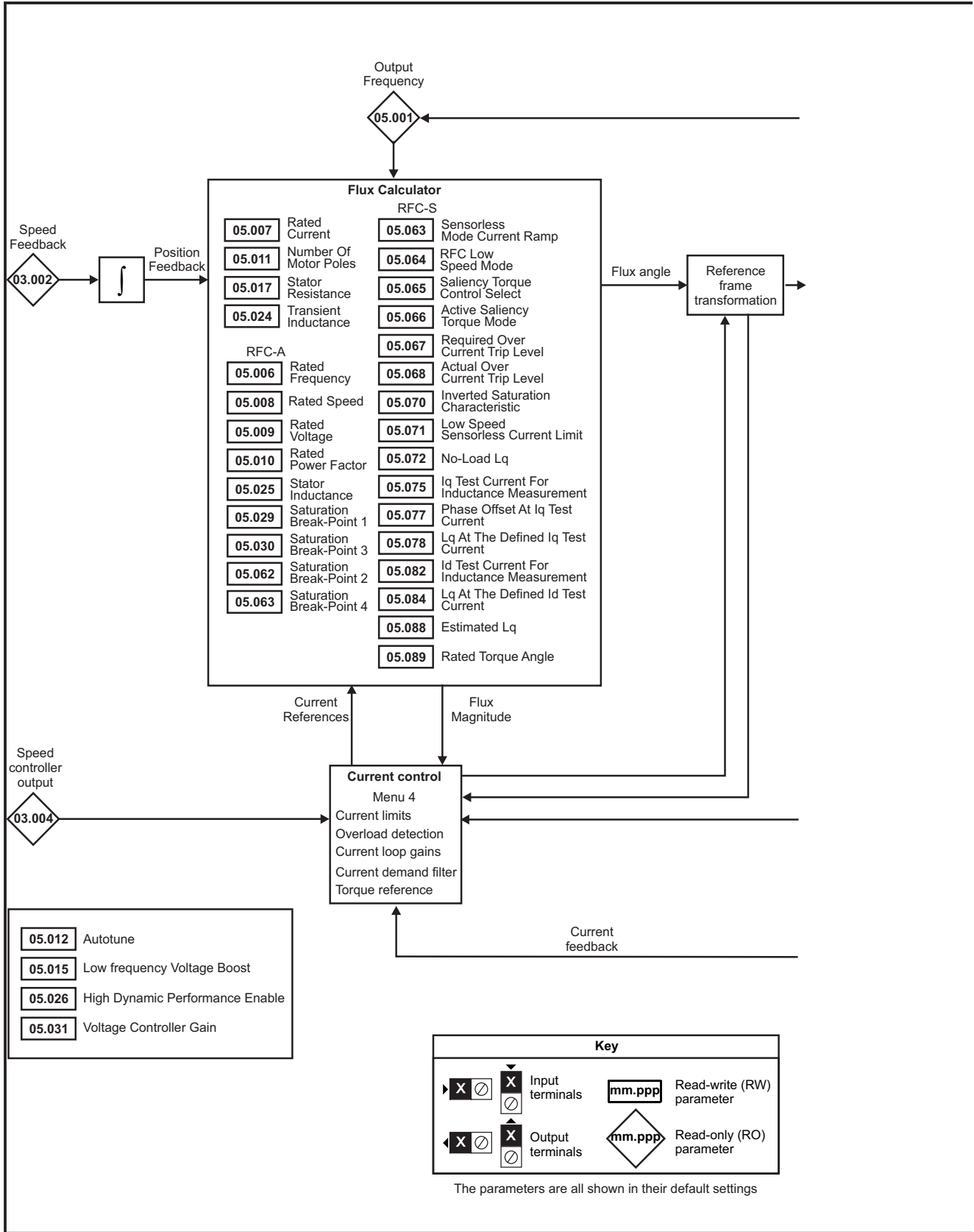

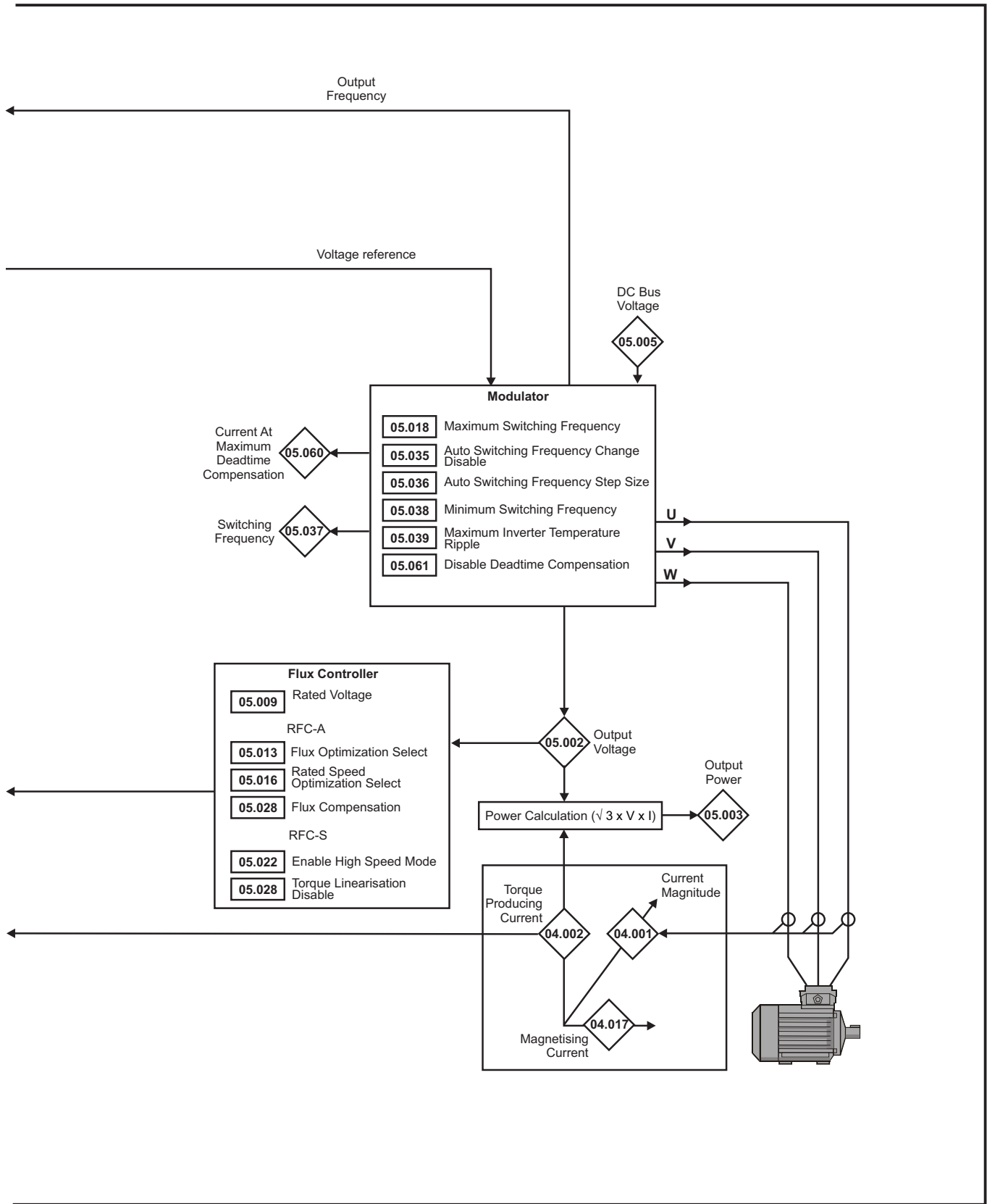

Parameter	Range(↕)			Default(⇒)			Type						
	OL	RFC-A	RFC-S	OL	RFC-A	RFC-S	RO	Num	ND	NC	PT	FI	
05.001	Output Frequency	VM_SPEED_FREQ_REF Hz	±2000.0 Hz					RO	Num	ND	NC	PT	FI
05.002	Output Voltage	0 to VM_AC_VOLTAGE V						RO	Num	ND	NC	PT	FI
05.003	Output Power	VM_POWER kW						RO	Num	ND	NC	PT	FI
05.004	Motor Rpm	±180000 rpm						RO	Num	ND	NC	PT	FI
05.005	D.c. Bus Voltage	0 to VM_DC_VOLTAGE V						RO	Num	ND	NC	PT	FI
05.006	Rated Frequency	0.0 to 550.0 Hz		50Hz: 50.0 60Hz: 60.0			RW	Num					US
05.007	Rated Current	0.000 to VM_RATED_CURRENT			Maximum Heavy Duty Rating (11.032)			RW	Num		RA		US
05.008	Rated Speed	0 to 33000 rpm	0.00 to 33000.00 rpm		50Hz - 1500 rpm 60Hz - 1800 rpm	50Hz - 1450.00 rpm 60Hz - 1750.00 rpm	3000.00 rpm	RW	Num				US
05.009	Rated Voltage	0 to VM_AC_VOLTAGE_SET V			200 V drive: 230 V 50Hz - 400 V drive: 400 V 60Hz - 400 V drive: 460 V 575 V drive: 575 V 690 V drive: 690 V			RW	Num		RA		US
05.010	Rated Power Factor	0.000 to 1.000		0.850			RW	Num		RA			US
05.011	Number Of Motor Poles	Automatic (0) to 480 Poles (240)			Automatic (0)		8 Poles (4)	RW	Txt				US
05.012	Autotune	0 to 2	0 to 5	0 to 6	0			RW	Num		NC		
05.013	Dynamic V To F Select	Off (0) or On (1)		Off (0)			RW	Bit					US
	Flux Optimization Select	Off (0) or On (1)		Off (0)			RW	Bit					US
05.014	Open-loop Control Mode	Ur S (0), Ur (1), Fixed (2), Ur Auto (3), Ur I (4), Square (5)		Ur I (4)			RW	Txt					US
05.015	Low Frequency Voltage Boost	0.0 to 25.0 %		3.0 %			RW	Num					US
	Minimal Movement Phasing Test Current			1,2,3,6,12,25, 50,100 %			1 %	RW	Num				US
05.016	Rated Speed Optimization Select	Disabled (0) Classic Slow (1) Classic fast (2) Combined (3) VARs Only (4) Voltage Only(5)		Disabled (0)			RW	Num					US
	Minimal Movement Phasing Test Angle			0.00 to 25.00 °			0.00 °	RW	Num				US
05.017	Stator Resistance	0.000000 to 1000.000000 Ω			0.000000 Ω			RW	Num		RA		US
05.018	Maximum Switching Frequency	2 (0) kHz, 3 (1) kHz, 4 (2) kHz, 6 (3) kHz, 8 (4) kHz, 12 (5) kHz, 16 (6) kHz			3 (1) kHz			RW	Txt		RA		US
05.019	High Stability Space Vector Modulation	Off (0) or On (1)		Off (0)			RW	Bit					US
	Rated Speed Optimisation Minimum Frequency	0 to 100 %		10 %			RW	Num					US
05.020	Quasi-square Enable	Off (0) or On (1)		Off (0)			RW	Bit					US
	Rated Speed Optimisation Minimum Load	0 to 100 %		50 %			RW	Num					US
05.021	Mechanical Load Test Level	0 to 100 %		0 %			RW	Num					US
05.022	Enable High Speed Mode	Limit (-1), Disable (0), Enable (1)		Limit (-1)			RW	Txt					US
05.023	D.c. Bus Voltage High Range	0 to VM_HIGH_DC_VOLTAGE						RO	Num	ND	NC	PT	FI
05.024	Transient Inductance / Ld	0.000 to 500.000 mH			0.000 mH			RW	Num		RA		US
05.025	Stator Inductance	0.00 to 5000.00 mH		0.00 mH			RW	Num		RA			US
05.026	High Dynamic Performance Enable	Off (0) or On (1)		Off (0)			RW	Bit		RA			US
05.027	Enable Slip Compensation	Off (0) or On (1)		On (1)			RW	Bit		RA			US
	Flux Control Gain	0.1 to 10.0		1.0			RW	Num					US
	Flux Compensation	0 to 2		0			RW	Num					US
05.028	Torque Linearisation Disable	Off (0) or On (1)		Off (0)			RW	Bit					US
05.029	Saturation Breakpoint 1	0.0 to 100.0 %		50.0 %			RW	Num					US
05.030	Saturation Breakpoint 3			75.0 %			RW	Num					US
05.031	Voltage Controller Gain	1 to 30			1			RW	Num				US
05.032	Torque Per Amp	0.00 to 500.00 Nm/A						RO	Num	ND	NC	PT	
05.033	Volts Per 1000rpm			0 to 10000 V			98 V	RW	Num				US
05.034	Percentage Flux	0.0 to 150.0 %					RO	Num	ND	NC	PT		

Parameter	Range(⇅)			Default(⇄)			Type					
	OL	RFC-A	RFC-S	OL	RFC-A	RFC-S						
05.035	Auto-switching Frequency Change Disable Enabled (0), Disabled (1), No Ripple Detect (2)			Enabled (0)			RW	Txt				US
05.036	Auto-switching Frequency Step Size 1 to 2			2			RW	Num				US
05.037	Switching Frequency 2 (0) kHz, 3 (1) kHz, 4 (2) kHz, 6 (3) kHz, 8 (4) kHz, 12 (5) kHz, 16 (6) kHz						RO	Txt	ND	NC	PT	
05.038	Minimum Switching Frequency 0 to VM_MIN_SWITCHING_FREQUENCY kHz			2 (0) kHz			RW	Txt				US
05.039	Maximum Inverter Temperature Ripple 20 to 60 °C			60 °C			RW	Num				US
05.040	Spin Start Boost 0.0 to 10.0			1.0			RW	Num				US
05.041	Voltage Headroom 0 to 20 %			0 % 10 %			RW	Num				US
05.042	Reverse Output Phase Sequence Off (0) or On (1)			Off (0)			RW	Bit				US
05.059	Maximum Deadtime Compensation 0.000 to 10.000 µs						RO	Num		NC	PT	US
05.060	Current At Maximum Deadtime Compensation 0.00 to 100.00 %						RO	Num		NC	PT	US
05.061	Disable Deadtime Compensation Off (0) or On (1)			Off (0)			RW	Bit				US
05.062	Saturation Breakpoint 2 0.0 to 100.0 %			0.0 %			RW	Num				US
05.063	Saturation Breakpoint 4 0.0 to 100.0 %			0.0 %			RW	Num				US
	Sensorless Mode Current Ramp 0.00 to 1.00 s			0.20 s			RW	Num				US
05.064	RFC Low Speed Mode Injection (0), Non-salient (1) Current (2) Current No Test (3)			Non-salient (1)			RW	Txt				US
05.065	Saliency Torque Control Select Disabled (0) Low (1) High (2) Auto (3)			Disabled (0)			RW	Txt				US
05.066	Active Saliency Torque Mode Disabled (0) Low (1) High (2)						RO	Txt	ND	NC	PT	US
05.067	Required Over-current Trip Level 0 to 100 %			0 %			RW	Num				US
05.068	Actual Over-Current Trip Level 0 to 500 %						RO	Num	ND	NC	PT	
05.070	Inverted Saturation Characteristic Off (0) or On (1)			Off (0)			RW	Bit				US
05.071	Low Speed Sensorless Mode Current Limit 0.0 to 1000.0 %			20.0 %			RW	Num		RA		US
05.072	No-load Lq 0.000 to 500.000 mH			0.000 mH			RW	Num		RA		US
05.075	Iq Test Current For Inductance Measurement 0 to 200 %			100 %			RW	Num				US
05.077	Phase Offset At Iq Test Current ±90.0 °			0.0 °			RW	Num		RA		US
05.078	Lq At The Defined Iq Test Current 0.000 to 500.000 mH			0.000 mH			RW	Num		RA		US
05.082	Id Test Current for Inductance Measurement -100 to 0 %			-50 %			RW	Num				US
05.084	Lq At The Defined Id Test Current 0.000 to 500.000 mH			0.000 mH			RW	Num		RA		US
05.088	Estimated Lq 0.000 to 500.000 mH						RO	Num	ND	NC	PT	FI
05.089	Rated Torque Angle 0 to 90 °						RO	Num	ND	NC	PT	

RW	Read / Write	RO	Read only	Num	Number parameter	Bit	Bit parameter	Txt	Text string	Bin	Binary parameter	FI	Filtered
ND	No default value	NC	Not copied	PT	Protected parameter	RA	Rating dependent	US	User save	PS	Power-down save	DE	Destination

## 10.7 Menu 6: Sequencer and clock

Figure 10-10 Menu 6 logic diagram

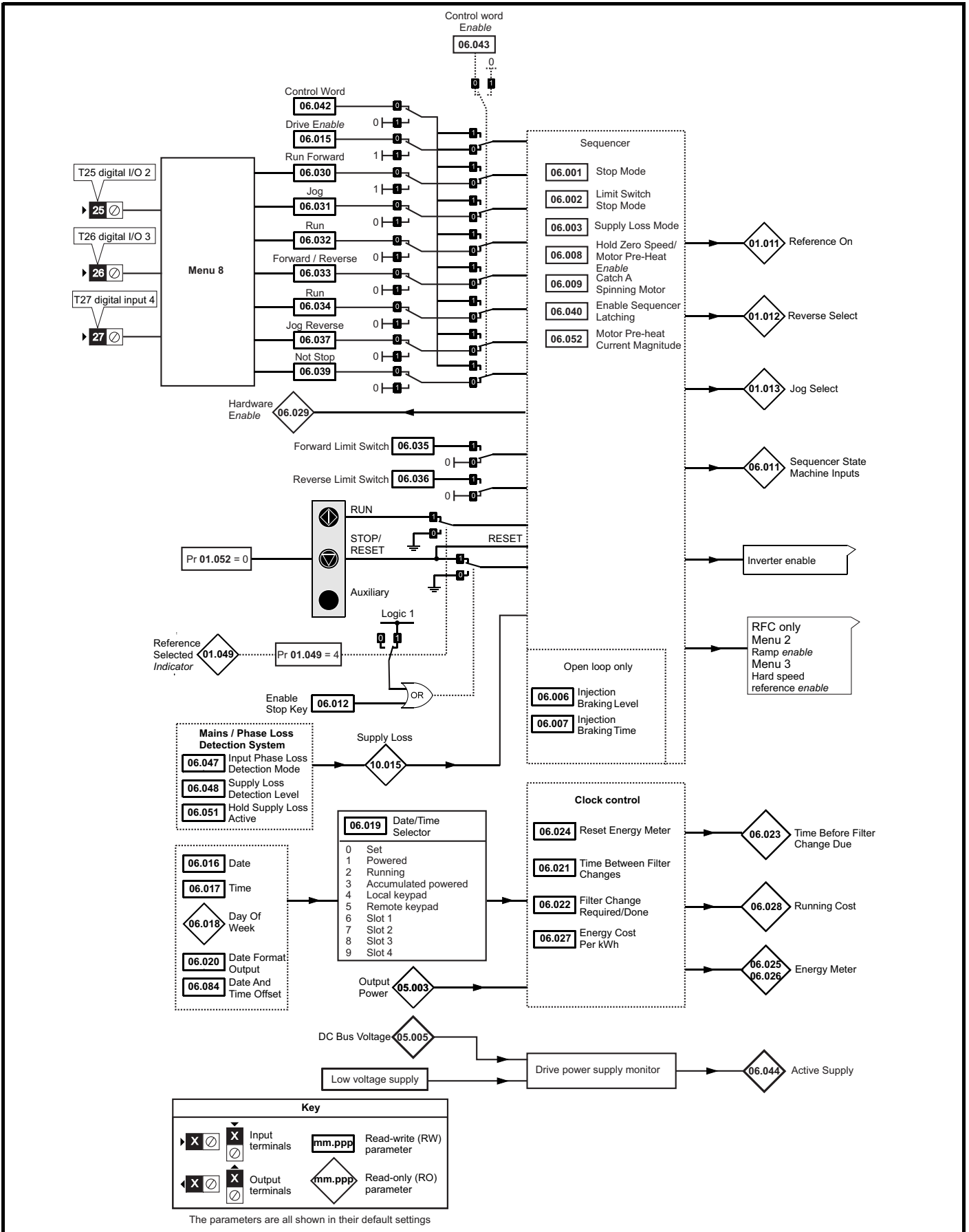

**Figure 10-11 Menu 6 under-voltage and power supply control**

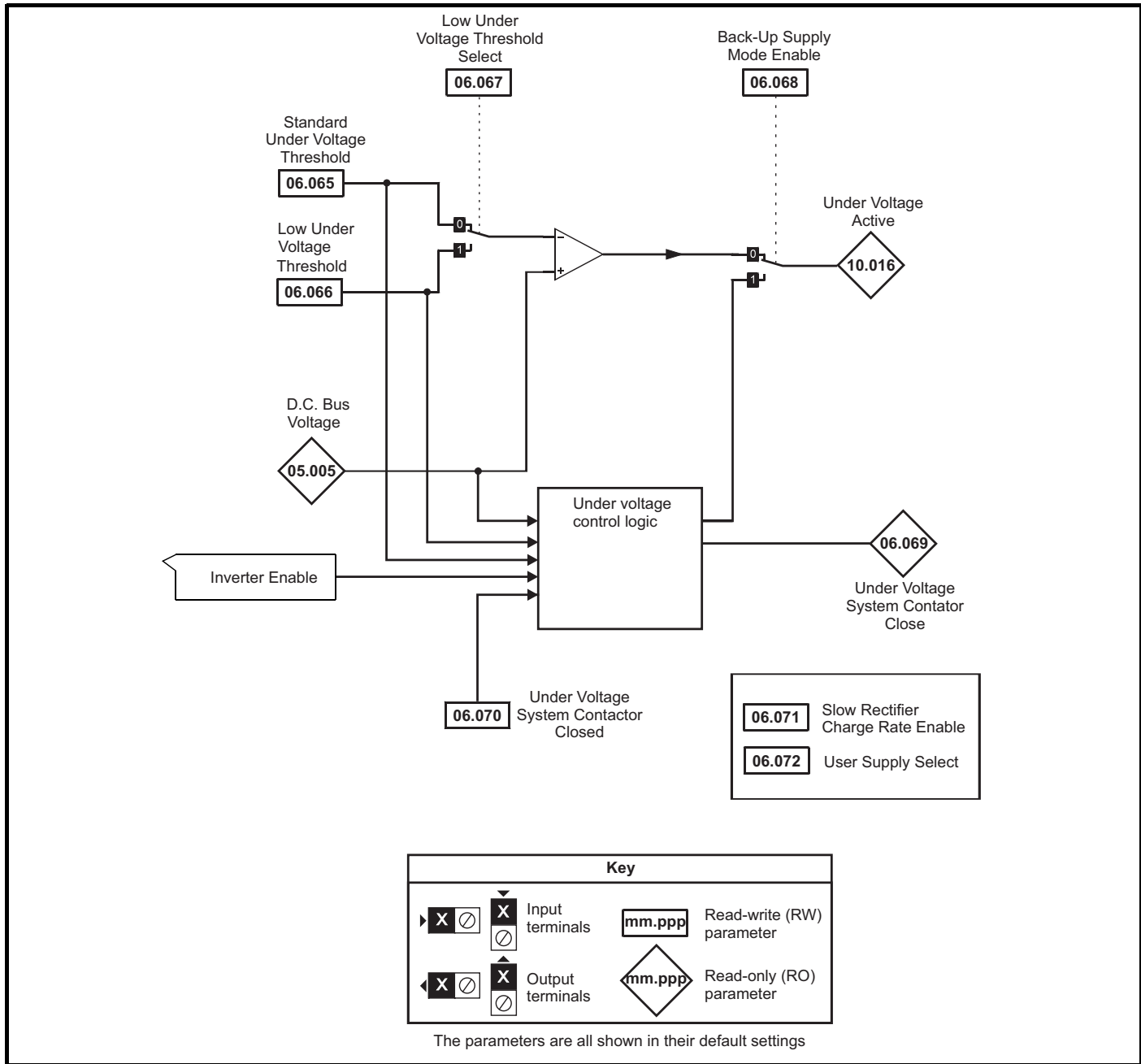

Parameter	Range(⊕)		Default(⇔)			Type					
	OL	RFC-A / S	OL	RFC-A	RFC-S						
06.001 Stop Mode	Coast (0), Ramp (1), Ramp dc I (2), dc I (3), Timed dc I (4), Disable (5)	Coast (0), Ramp (1), No Ramp (2)	Ramp (1)			RW	Txt				US
06.002 Limit Switch Stop Mode		Stop (0) or Ramp (1)		Stop (0)		RW	Txt				US
06.003 Supply Loss Mode	Disable (0), Ramp Stop (1), Ride Thru (2)	Disable (0), Ramp Stop (1), Ride Thru (2), Limit Stop (3)	Disable (0)			RW	Txt				US
06.006 Injection Braking Level	0.0 to 150.0 %		100.0 %			RW	Num		RA		US
06.007 Injection Braking Time	0.0 to 100.0 s		1.0 s			RW	Num				US
06.008 Hold Zero Speed	Off (0) or On (1)		Off (0)			RW	Bit				US
06.009 Catch A Spinning Motor	Disable (0), Enable (1), Fwd Only (2), Rev Only (3)		Disable (0)			RW	Txt				US
06.010 Enable Conditions	000000000000 to 111111111111					RO	Bin	ND	NC	PT	
06.011 Sequencer State Machine Inputs	0000000 to 1111111					RO	Bin	ND	NC	PT	
06.012 Enable Stop Key	Off (0) or On (1)		Off (0)			RW	Bit				US
06.013 Enable Auxiliary Key	Disabled (0), Forward / Reverse (1), Run Reverse (2)		Disabled (0)			RW	Txt				US
06.015 Drive Enable	Off (0) or On (1)		On (1)			RW	Bit				US
06.016 Date	00-00-00 to 31-12-99		00-00-00			RW	Date	ND	NC	PT	
06.017 Time	00:00:00 to 23:59:59					RW	Time	ND	NC	PT	
06.018 Day Of Week	Sunday (0), Monday (1), Tuesday (2), Wednesday (3), Thursday (4), Friday (5), Saturday (6)					RO	Txt	ND	NC	PT	
06.019 Date/Time Selector	Set (0), Powered (1), Running (2), Acc Powered (3), Local Keypad (4), Remote Keypad (5), Slot 1 (6), Slot 2 (7), Slot 3 (8), Slot 4 (9)		Powered (1)			RW	Txt				US
06.020 Date Format	Std (0) or US (1)		Std (0)			RW	Txt				US
06.021 Time Between Filter Changes	0 to 30000 Hours		0 Hours			RW	Num				US
06.022 Filter Change Required / Change Done	Off (0) or On (1)		Off (0)			RW	Bit	ND	NC		
06.023 Time Before Filter Change Due	0 to 30000 Hours					RO	Num	ND	NC	PT	PS
06.024 Reset Energy Meter	Off (0) or On (1)		Off (0)			RW	Bit				
06.025 Energy Meter: MWh	±999.9 MWh					RO	Num	ND	NC	PT	PS
06.026 Energy Meter: kWh	±99.99 kWh					RO	Num	ND	NC	PT	PS
06.027 Energy Cost Per kWh	0.0 to 600.0		0.0			RW	Num				US
06.028 Running Cost	±32000					RO	Num	ND	NC	PT	
06.029 Hardware Enable	Off (0) or On (1)					RO	Bit	ND	NC	PT	
06.030 Run Forward	Off (0) or On (1)		Off (0)			RW	Bit		NC		
06.031 Jog	Off (0) or On (1)		Off (0)			RW	Bit		NC		
06.032 Run Reverse	Off (0) or On (1)		Off (0)			RW	Bit		NC		
06.033 Forward/Reverse	Off (0) or On (1)		Off (0)			RW	Bit		NC		
06.034 Run	Off (0) or On (1)		Off (0)			RW	Bit		NC		
06.035 Forward Limit Switch	Off (0) or On (1)		Off (0)			RW	Bit		NC		
06.036 Reverse Limit Switch	Off (0) or On (1)		Off (0)			RW	Bit		NC		
06.037 Jog Reverse	Off (0) or On (1)		Off (0)			RW	Bit		NC		
06.039 Not Stop	Off (0) or On (1)		Off (0)			RW	Bit		NC		
06.040 Enable Sequencer Latching	Off (0) or On (1)		Off (0)			RW	Bit				US
06.041 Drive Event Flags	00 to 11		00			RW	Bin		NC		
06.042 Control Word	00000000000000 to 1111111111111111		0000000000000000			RW	Bin		NC		
06.043 Control Word Enable	Off (0) or On (1)		Off (0)			RW	Bit				US
06.044 Active Supply	Off (0) or On (1)					RO	Bit	ND	NC	PT	
06.045 Cooling Fan control	0 to 11		10			RW	Num				US
06.047 Input Phase Loss Detection Mode	Full (0), Ripple Only (1), Disabled (2)		Full (0)			RW	Txt				US
06.048 Supply Loss Detection Level	0 to VM_SUPPLY_LOSS_LEVEL		200 V drive: 205 V 400 V drive: 410 V 575 V drive: 540 V 690 V drive: 540 V			RW	Num		RA		US
06.051 Hold Supply Loss Active	Off (0) or On (1)		Off (0)			RW	Bit		NC		
06.052 Motor Pre-heat Current Magnitude	0 to 100 %		0 %			RW	Num				US
06.058 Output Phase Loss Detection Time	0.5 s (0) 1.0 s (1) 2.0 s (2) 4.0 s (3)		0.5 s (0)			RW	Txt				US
06.059 Output Phase Loss Detection Enable	Disabled (0), Enabled (1)		Disabled (0)			RW	Txt				US
06.060 Standby Mode Enable	Off (0) or On (1)		Off (0)			RW	Bit				US

Parameter		Range(⇅)		Default(⇄)			Type						
		OL	RFC-A / S	OL	RFC-A	RFC-S	RW	Bin				US	
06.061	Standby Mode Mask	0000000 to 1111111		0000000			RW	Bin					US
06.065	Standard Under Voltage Threshold	0 to VM_STD_UNDER_VOLTS		200 V drive: 175 V 400 V drive: 330 V 575 V drive: 435 V 690 V drive: 435 V			RW	Num			RA		US
06.066	Low Under Voltage Threshold	24 to VM_LOW_UNDER_VOLTS		200 V drive: 175 V 400 V drive: 330 V 575 V drive: 435 V 690 V drive: 435 V			RW	Num			RA		US
06.067	Low Under Voltage Threshold Select	Off (0) or On (1)		Off (0)			RW	Bit					US
06.068	Back Up Supply Mode Enable	Off (0) or On (1)		Off (0)			RW	Bit					US
06.069	Under-Voltage System Contactor Close	Off (0) or On (1)					RO	Bit	ND	NC	PT		
06.070	Under-Voltage System Contactor Closed	Off (0) or On (1)		Off (0)			RW	Bit					US
06.071	Slow Rectifier Charge Rate Enable	Off (0) or On (1)		Off (0)			RW	Bit					US
06.072	User Supply Select	Off (0) or On (1)		Off (0)			RW	Bit					US
06.073	Braking IGBT Lower Threshold	0 to VM_DC_VOLTAGE_SET V		200 V drive: 390 V 400 V drive: 780 V 575 V drive: 930 V 690 V drive: 1120 V			RW	Num			RA		US
06.074	Braking IGBT Upper Threshold	0 to VM_DC_VOLTAGE_SET V		200 V drive: 390 V 400 V drive: 780 V 575 V drive: 930 V 690 V drive: 1120 V			RW	Num			RA		US
06.075	Low Voltage Braking IGBT Threshold	0 to VM_DC_VOLTAGE_SET V		0 V			RW	Num			RA		US
06.076	Low Voltage Braking IGBT Threshold Select	Off (0) or On (1)		Off (0)			RW	Bit					
06.084	Date And Time Offset	±24.00 Hours		0.00 Hours			RW	Num					US

RW	Read / Write	RO	Read only	Num	Number parameter	Bit	Bit parameter	Txt	Text string	Bin	Binary parameter	FI	Filtered
ND	No default value	NC	Not copied	PT	Protected parameter	RA	Rating dependent	US	User save	PS	Power-down save	DE	Destination
IP	IP address	Mac	Mac address	Date	Date parameter	Time	Time parameter	SMP	Slot,menu,parameter	Chr	Character parameter	Ver	Version number

## 10.8 Menu 7: Analog I/O

Figure 10-12 Menu 7 analog inputs logic diagram

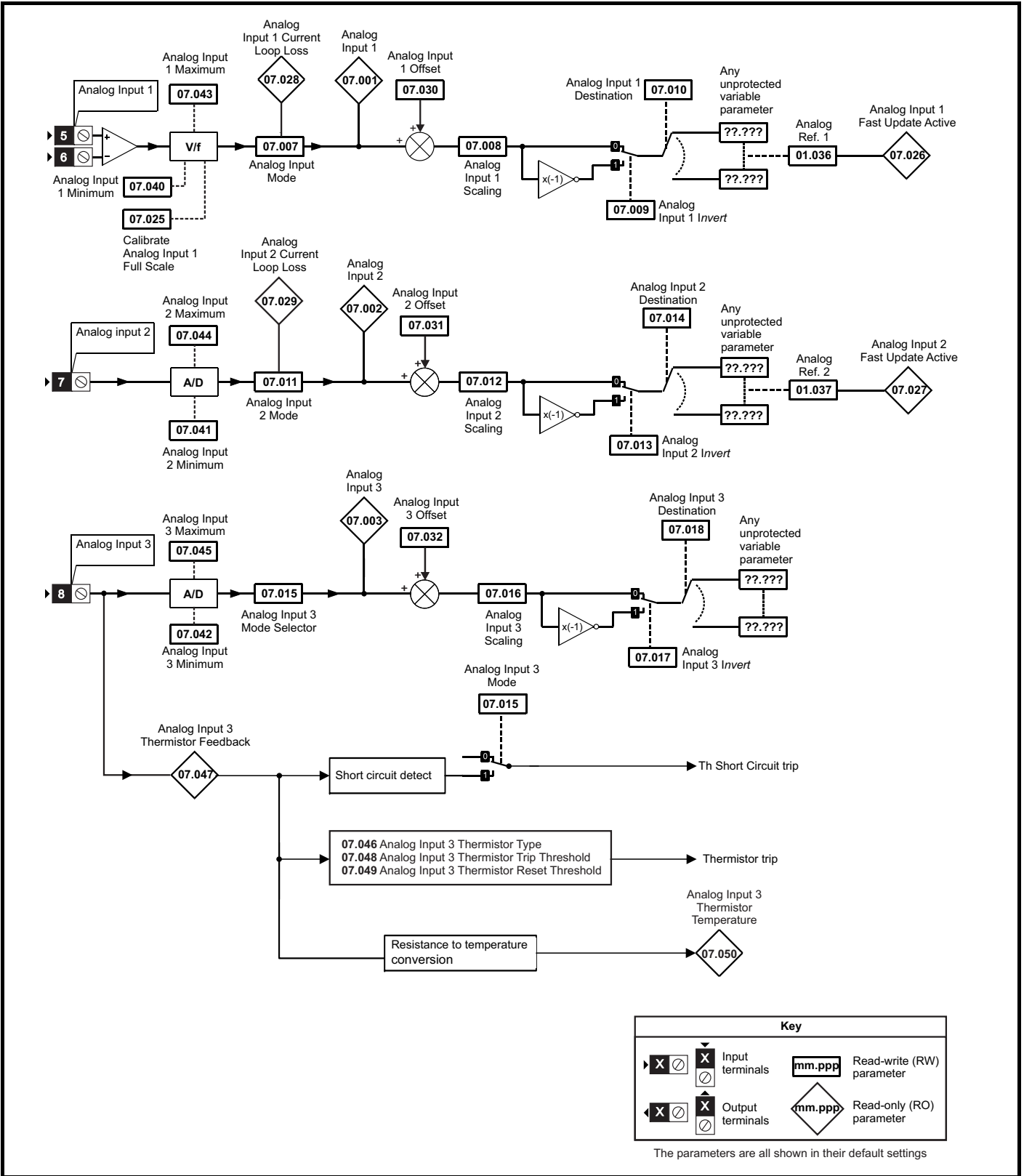

**Figure 10-13 Menu 7 analog outputs diagram**

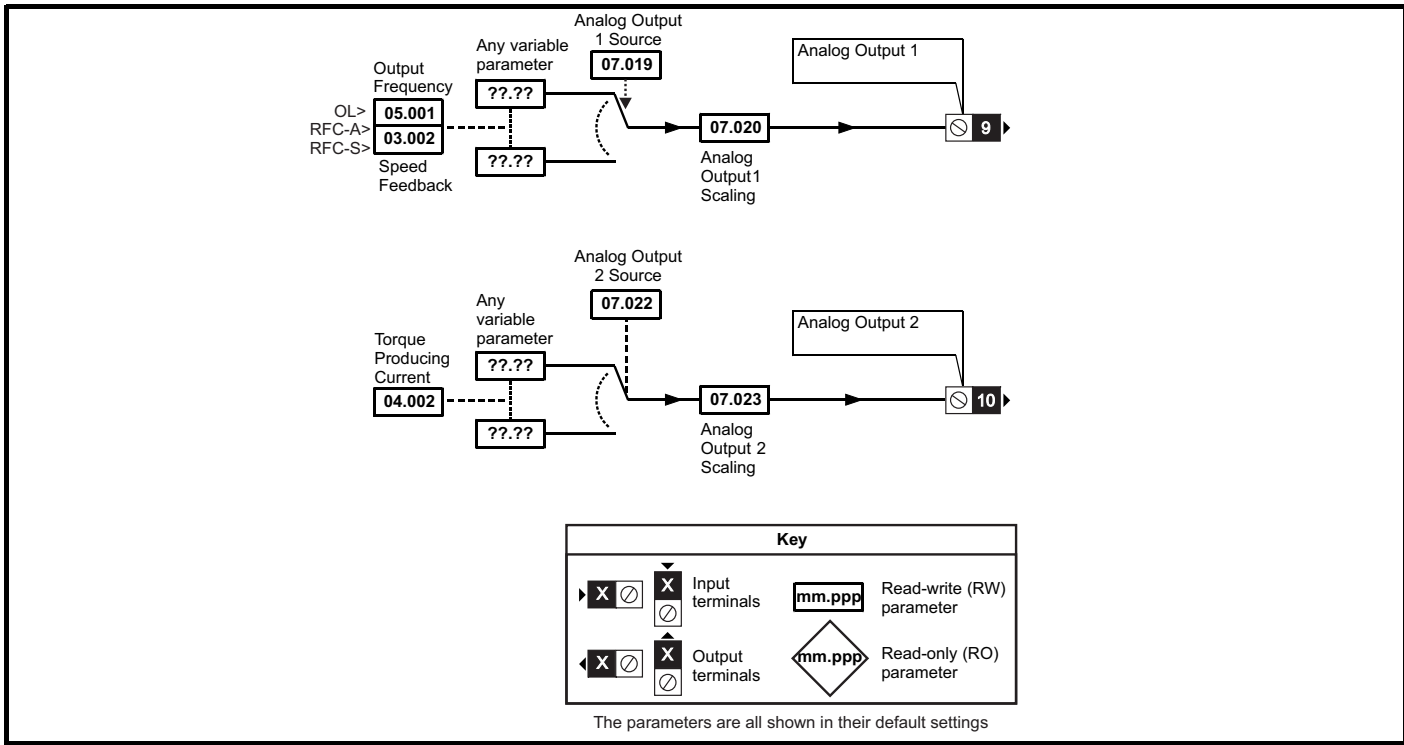

**Figure 10-14 Menu 7 thermal monitoring diagram**

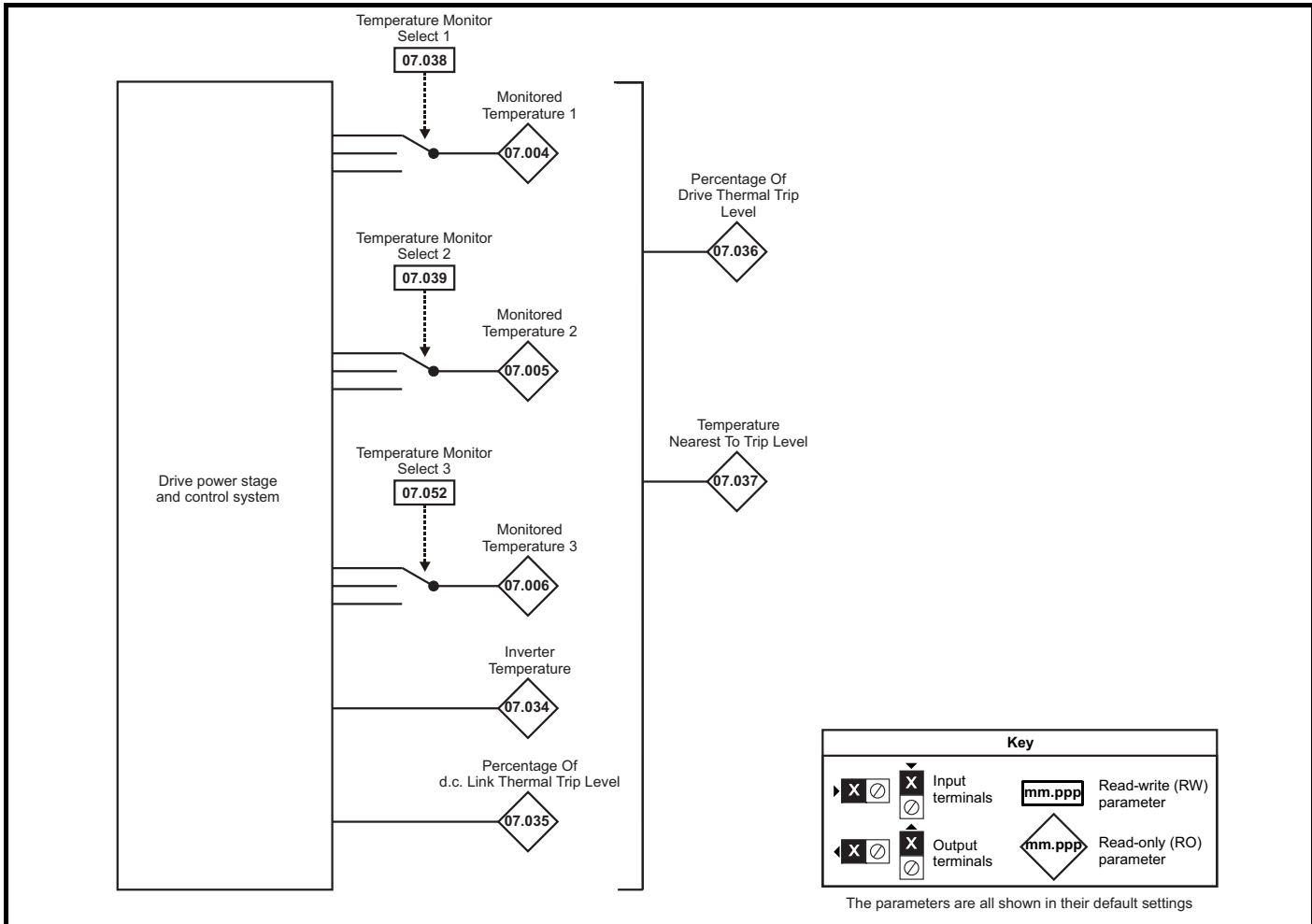

Parameter	Range(†)		Default(⇒)			Type					
	OL	RFC-A / S	OL	RFC-A	RFC-S						
07.001	Analog Input 1	±100.00 %				RO	Num	ND	NC	PT	FI
07.002	Analog Input 2	±100.00 %				RO	Num	ND	NC	PT	FI
07.003	Analog Input 3	±100.00 %				RO	Num	ND	NC	PT	FI
07.004	Monitored Temperature 1	±250 °C				RO	Num	ND	NC	PT	
07.005	Monitored Temperature 2	±250 °C				RO	Num	ND	NC	PT	
07.006	Monitored Temperature 3	±250 °C				RO	Num	ND	NC	PT	
07.007	Analog Input 1 Mode	4-20 mA Low (-4), 20-4 mA Low (-3), 4-20 mA Hold (-2), 20-4 mA Hold (-1), 0-20 mA (0), 20-0 mA (1), 4-20 mA Trip (2), 20-4 mA Trip (3), 4-20 mA (4), 20-4 mA (5), Volt (6)		Volt (6)		RW	Txt				US
07.008	Analog Input 1 Scaling	0.000 to 10.000		1.000		RW	Num				US
07.009	Analog Input 1 Invert	Off (0) or On (1)		Off (0)		RW	Bit				US
07.010	Analog Input 1 Destination	0.000 to 59.999		1.036		RW	Num	DE		PT	US
07.011	Analog Input 2 Mode	4-20 mA Low (-4), 20-4 mA Low (-3), 4-20 mA Hold (-2), 20-4 mA Hold (-1), 0-20 mA (0), 20-0 mA (1), 4-20 mA Trip (2), 20-4 mA Trip (3), 4-20 mA (4), 20-4 mA (5), Volt (6)		Volt (6)		RW	Txt				US
07.012	Analog Input 2 Scaling	0.000 to 10.000		1.000		RW	Num				US
07.013	Analog Input 2 Invert	Off (0) or On (1)		Off (0)		RW	Bit				US
07.014	Analog Input 2 Destination	0.000 to 59.999		1.037		RW	Num	DE		PT	US
07.015	Analog Input 3 Mode	Volt (6), Therm Short Cct (7), Thermistor (8), Therm No Trip (9)		Volt (6)		RW	Txt				US
07.016	Analog Input 3 Scaling	0.000 to 10.000		1.000		RW	Num				US
07.017	Analog Input 3 Invert	Off (0) or On (1)		Off (0)		RW	Bit				US
07.018	Analog Input 3 Destination	0.000 to 59.999		0.000		RW	Num	DE		PT	US
07.019	Analog Output 1 Source	0.000 to 59.999	5.001	3.002		RW	Num			PT	US
07.020	Analog Output 1 Scaling	0.000 to 10.000		1.000		RW	Num				US
07.022	Analog Output 2 Source	0.000 to 59.999		4.002		RW	Num			PT	US
07.023	Analog Output 2 Scaling	0.000 to 10.000		1.000		RW	Num				US
07.025	Calibrate Analog Input 1 Full Scale	Off (0) or On (1)		Off (0)		RW	Bit		NC		
07.026	Analog Input 1 Fast Update Active	Off (0) or On (1)				RO	Bit	ND	NC	PT	
07.027	Analog Input 2 Fast Update Active	Off (0) or On (1)				RO	Bit	ND	NC	PT	
07.028	Analog Input 1 Current Loop Loss					RO	Bit	ND	NC	PT	
07.029	Analog Input 2 Current Loop Loss	Off (0) or On (1)				RO	Bit	ND	NC	PT	
07.030	Analog Input 1 Offset	±100.00 %		0.00 %		RW	Num				US
07.031	Analog Input 2 Offset	±100.00 %		0.00 %		RW	Num				US
07.032	Analog Input 3 Offset	±100.00 %		0.00 %		RW	Num				US
07.033	Power Output	±100.0 %				RO	Num	ND	NC	PT	
07.034	Inverter Temperature	±250 °C				RO	Num	ND	NC	PT	
07.035	Percentage Of d.c. Bus Thermal Trip Level	0 to 100 %				RO	Num	ND	NC	PT	
07.036	Percentage Of Drive Thermal Trip Level	0 to 100 %				RO	Num	ND	NC	PT	
07.037	Temperature Nearest To Trip Level	0 to 20999				RO	Num	ND	NC	PT	
07.038	Temperature Monitor Select 1	0 to 1999		1001		RW	Num				US
07.039	Temperature Monitor Select 2	0 to 1999		1002		RW	Num				US
07.040	Analog Input 1 Minimum	±100.00 %		-100.00 %		RW	Num				US
07.041	Analog Input 2 Minimum	±100.00 %		-100.00 %		RW	Num				US
07.042	Analog Input 3 Minimum	±100.00 %		-100.00 %		RW	Num				US
07.043	Analog Input 1 Maximum	±100.00 %		100.00 %		RW	Num				US
07.044	Analog Input 2 Maximum	±100.00 %		100.00 %		RW	Num				US
07.045	Analog Input 3 Maximum	±100.00 %		100.00 %		RW	Num				US
07.046	Analog Input 3 Thermistor Type	DIN44082 (0), KTY84 (1), PT100 (4W) (2), PT1000 (4W) (3), PT2000 (4W) (4), 2.0 mA (4W) (5), PT100 (2W) (6), PT1000 (2W) (7), PT2000 (2W) (8), 2.0 mA (2W) (9)		DIN44082 (0)		RW	Txt				US
07.047	Analog Input 3 Thermistor Feedback	0 to 5000 Ω				RO	Num	ND	NC	PT	
07.048	Analog Input 3 Thermistor Trip Threshold	0 to 5000 Ω		3300 Ω		RW	Num				US
07.049	Analog Input 3 Thermistor Reset Threshold	0 to 5000 Ω		1800 Ω		RW	Num				US
07.050	Analog Input 3 Thermistor Temperature	-50 to 300 °C				RO	Num	ND	NC	PT	
07.051	Analog Input 1 Full Scale	0 to 65535				RO	Num	ND	NC	PT	PS
07.052	Temperature Monitor Select 3	0 to 1999		1		RW	Num				US

RW	Read / Write	RO	Read only	Num	Number parameter	Bit	Bit parameter	Txt	Text string	Bin	Binary parameter	FI	Filtered
ND	No default value	NC	Not copied	PT	Protected parameter	RA	Rating dependent	US	User save	PS	Power-down save	DE	Destination



## 10.9 Menu 8: Digital I/O

Figure 10-15 Menu 8 logic diagram

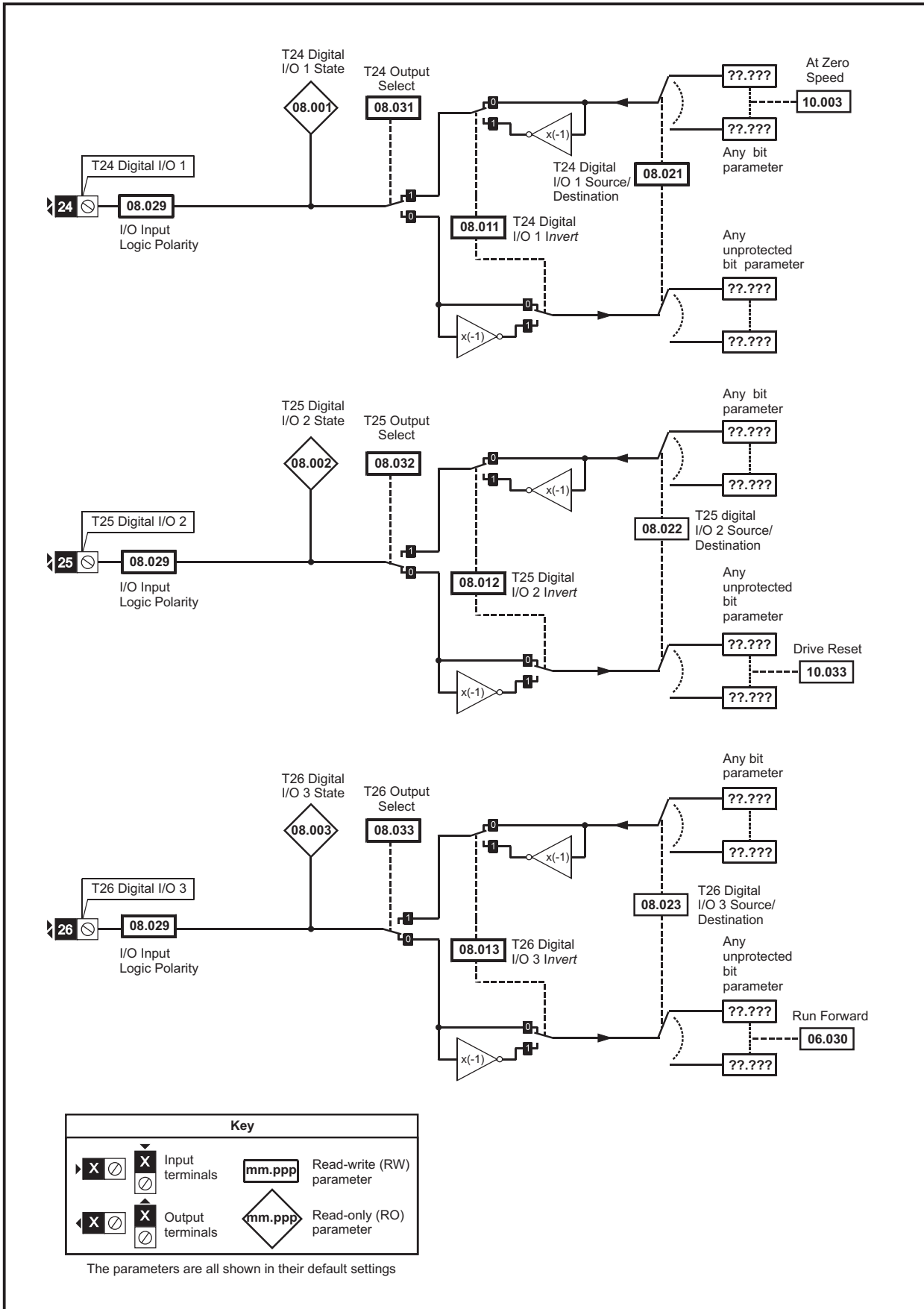

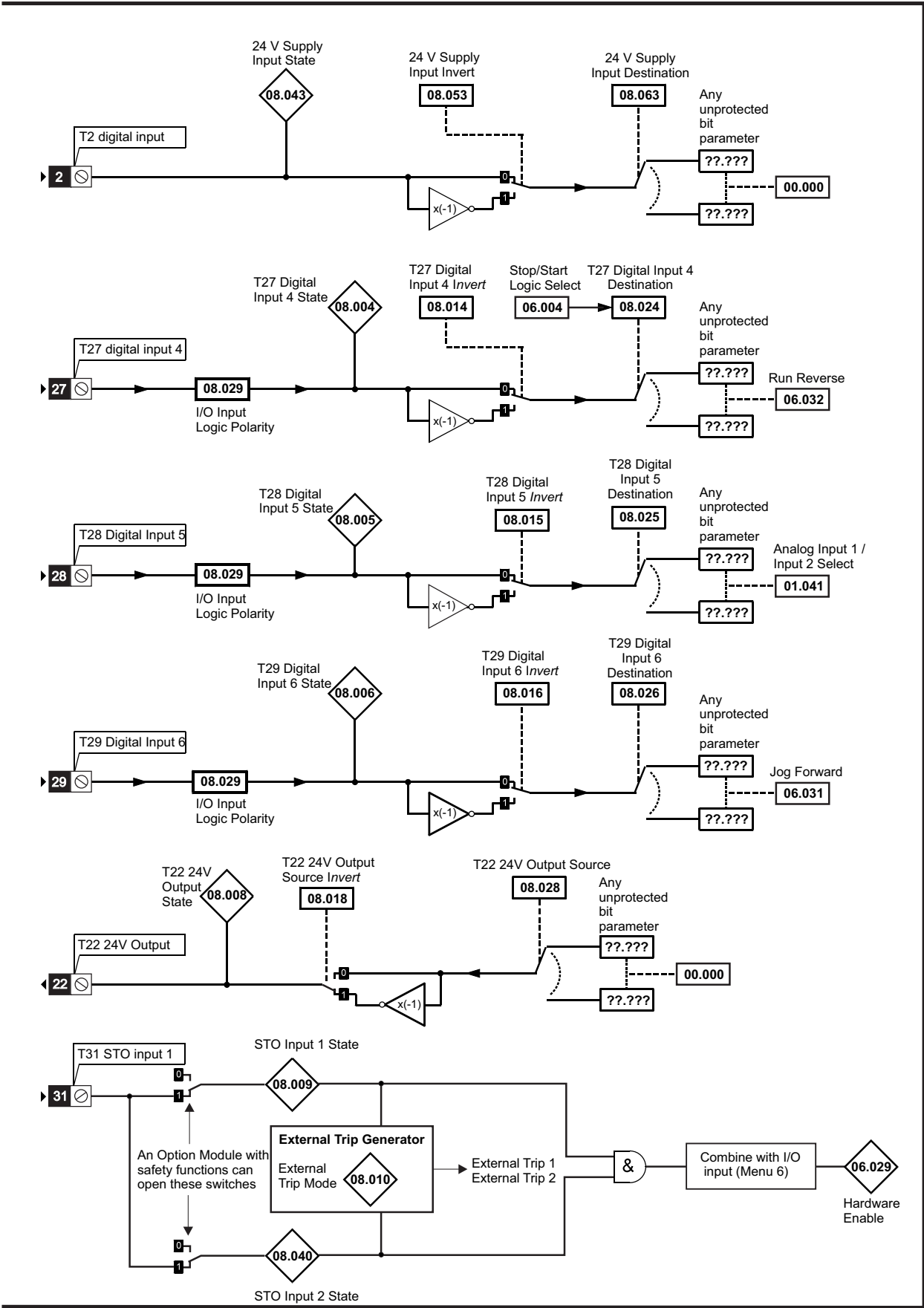

Figure 10-16 Menu 8 Relay output logic diagram

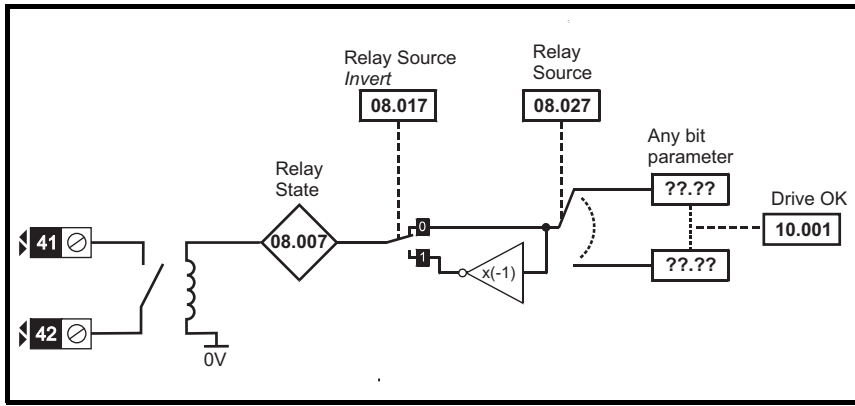
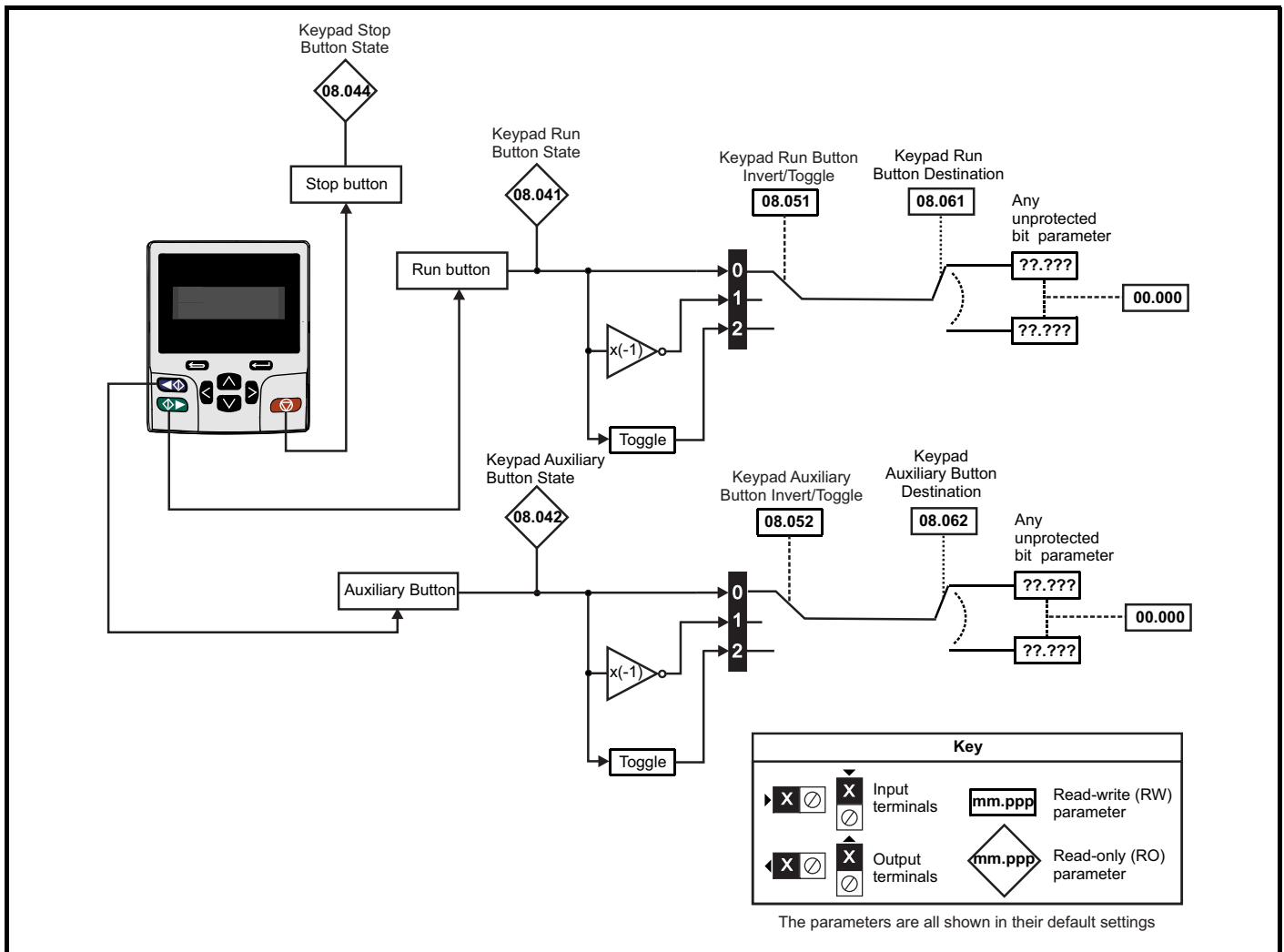

Figure 10-17 Menu 8 Keypad buttons logic diagram



Parameter		Range(⇅)		Default(⇒)			Type					
		OL	RFC-A / S	OL	RFC-A	RFC-S						
08.001	Digital I/O 01 State	Off (0) or On (1)					RO	Bit	ND	NC	PT	
08.002	Digital I/O 02 State	Off (0) or On (1)					RO	Bit	ND	NC	PT	
08.003	Digital I/O 03 State	Off (0) or On (1)					RO	Bit	ND	NC	PT	
08.004	Digital Input 04 State	Off (0) or On (1)					RO	Bit	ND	NC	PT	
08.005	Digital Input 05 State	Off (0) or On (1)					RO	Bit	ND	NC	PT	
08.006	Digital Input 06 State	Off (0) or On (1)					RO	Bit	ND	NC	PT	
08.007	Relay Output State	Off (0) or On (1)					RO	Bit	ND	NC	PT	
08.008	24V Supply Output State	Off (0) or On (1)					RO	Bit	ND	NC	PT	
08.009	STO Input 01 State	Off (0) or On (1)					RO	Bit	ND	NC	PT	
08.010	External Trip Mode	Disable (0), STO 1 (1), STO 2 (2), STO 1 OR STO 2 (3)				Disable (0)	RW	Txt				US
08.011	Digital I/O 01 Invert	Not Invert (0) or Invert (1)				Not Invert (0)	RW	Txt				US
08.012	Digital I/O 02 Invert	Not Invert (0) or Invert (1)				Not Invert (0)	RW	Txt				US
08.013	Digital I/O 03 Invert	Not Invert (0) or Invert (1)				Not Invert (0)	RW	Txt				US
08.014	Digital Input 04 Invert	Not Invert (0) or Invert (1)				Not Invert (0)	RW	Txt				US
08.015	Digital Input 05 Invert	Not Invert (0) or Invert (1)				Not Invert (0)	RW	Txt				US
08.016	Digital Input 06 Invert	Not Invert (0) or Invert (1)				Not Invert (0)	RW	Txt				US
08.017	Relay Invert	Not Invert (0) or Invert (1)				Not Invert (0)	RW	Txt				US
08.018	24V Supply Output Invert	Not Invert (0) or Invert (1)				Invert (1)	RW	Txt				US
08.020	Digital I/O Read Word	0 to 511					RO	Num	ND	NC	PT	
08.021	Digital I/O 01 Source/Destination	0.000 to 59.999				10.003	RW	Num	DE		PT	US
08.022	Digital I/O 02 Source/Destination	0.000 to 59.999				10.033	RW	Num	DE		PT	US
08.023	Digital I/O 03 Source/Destination	0.000 to 59.999				6.030	RW	Num	DE		PT	US
08.024	Digital Input 04 Destination	0.000 to 59.999				6.032	RW	Num	DE		PT	US
08.025	Digital Input 05 Destination	0.000 to 59.999				1.041	RW	Num	DE		PT	US
08.026	Digital Input 06 Destination	0.000 to 59.999				6.031	RW	Num	DE		PT	US
08.027	Relay Output Source	0.000 to 59.999				10.001	RW	Num			PT	US
08.028	24V Supply Output Source	0.000 to 59.999				0.000	RW	Num			PT	US
08.029	Input Logic Polarity	Negative Logic (0) or Positive Logic (1)				Positive Logic (1)	RW	Txt				US
08.031	Digital I/O 01 Output Select	Off (0) or On (1)				On (1)	RW	Bit				US
08.032	Digital I/O 02 Output Select	Off (0) or On (1)					RW	Bit				US
08.033	Digital I/O 03 Output Select	Off (0) or On (1)				Off (0)	RW	Bit				US
08.040	STO Input 02 State	Off (0) or On (1)					RO	Bit	ND	NC	PT	
08.041	Keypad Run Button State	Off (0) or On (1)					RO	Bit	ND	NC	PT	
08.042	Keypad Auxiliary Button State	Off (0) or On (1)					RO	Bit	ND	NC	PT	
08.043	24V Supply Input State	Off (0) or On (1)					RO	Bit	ND	NC	PT	
08.044	Keypad Stop Button State	Off (0) or On (1)					RO	Bit	ND	NC	PT	
08.051	Keypad Run Button Invert/Toggle	Not Invert (0), Invert (1) or Toggle (2)				Not Invert (0)	RW	Txt				US
08.052	Keypad Auxiliary Button Invert/Toggle	Not Invert (0), Invert (1) or Toggle (2)				Not Invert (0)	RW	Txt				US
08.053	24V Supply Input Invert	Not Invert (0) or Invert (1)				Not Invert (0)	RW	Txt				US
08.061	Keypad Run Button Destination	0.000 to 59.999				0.000	RW	Num	DE		PT	US
08.062	Keypad Auxiliary Button Destination	0.000 to 59.999				0.000	RW	Num	DE		PT	US
08.063	24V Supply Input Destination	0.000 to 59.999				0.000	RW	Num	DE		PT	US
08.071	DI/O Output Enable Register 1	0000000000000000 to 1111111111111111				0000000000000000	RW	Bin			PT	US
08.072	DI/O Input Register 1	0000000000000000 to 1111111111111111					RO	Bin	ND	NC	PT	
08.073	DI/O Output Register 1	0000000000000000 to 1111111111111111				0000000000000000	RW	Bin			PT	

RW	Read / Write	RO	Read only	Num	Number parameter	Bit	Bit parameter	Txt	Text string	Bin	Binary parameter	FI	Filtered
ND	No default value	NC	Not copied	PT	Protected parameter	RA	Rating dependent	US	User save	PS	Power-down save	DE	Destination

## 10.10 Menu 9: Programmable logic, motorized pot, binary sum and timers

Figure 10-18 Menu 9 logic diagram: Programmable logic

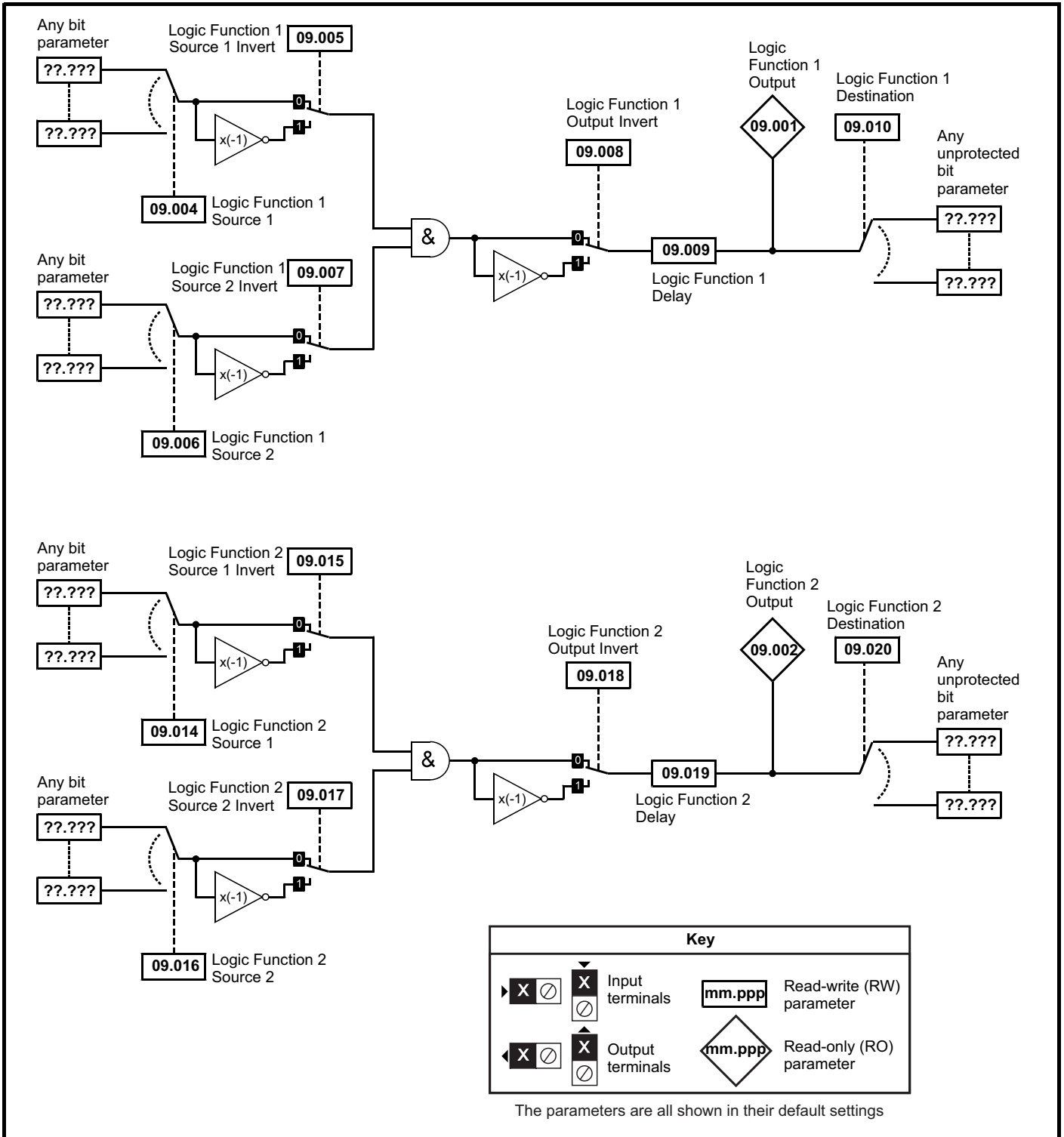

**Figure 10-19 Menu 9 logic diagram: Motorized pot and binary sum**

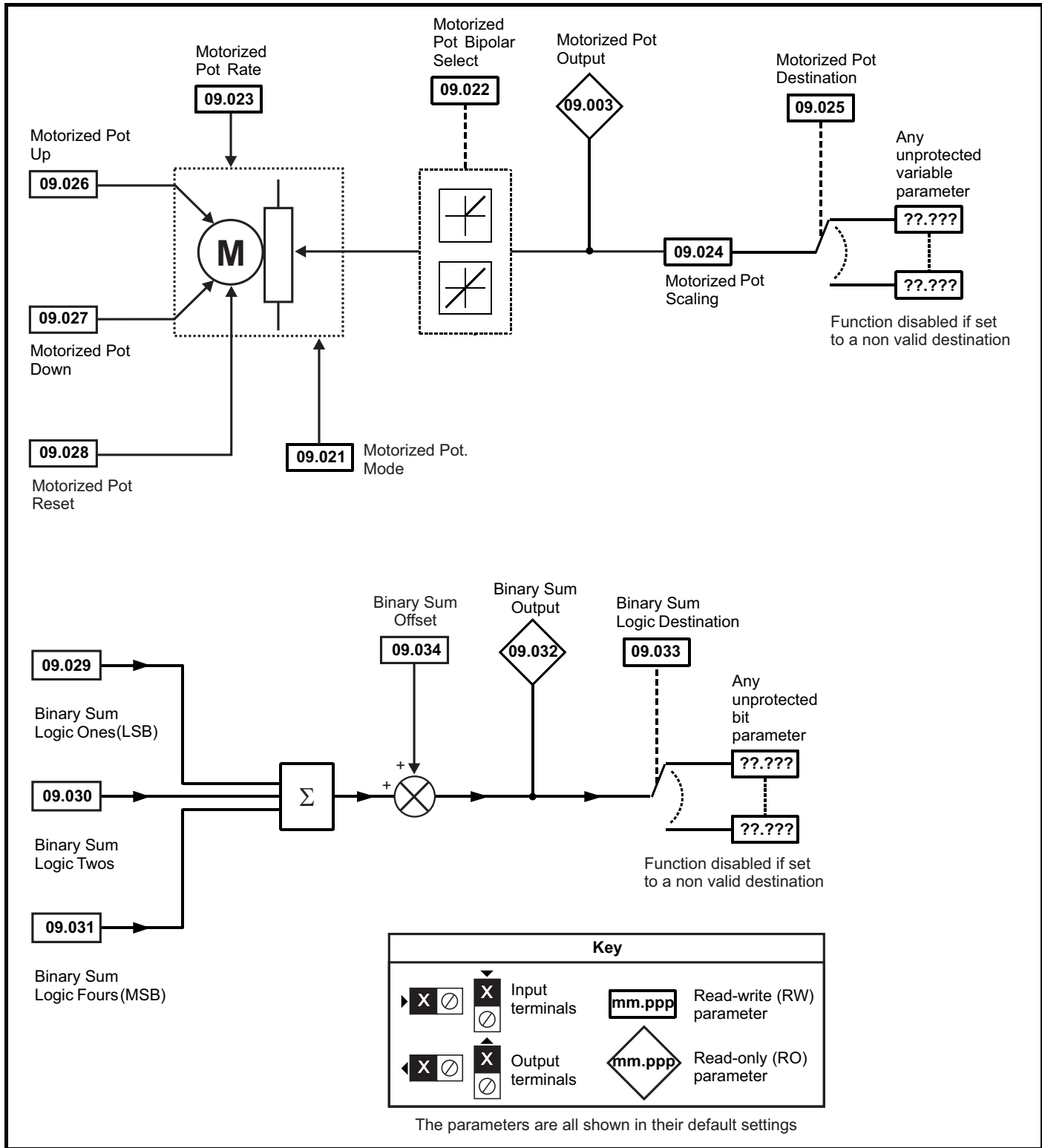
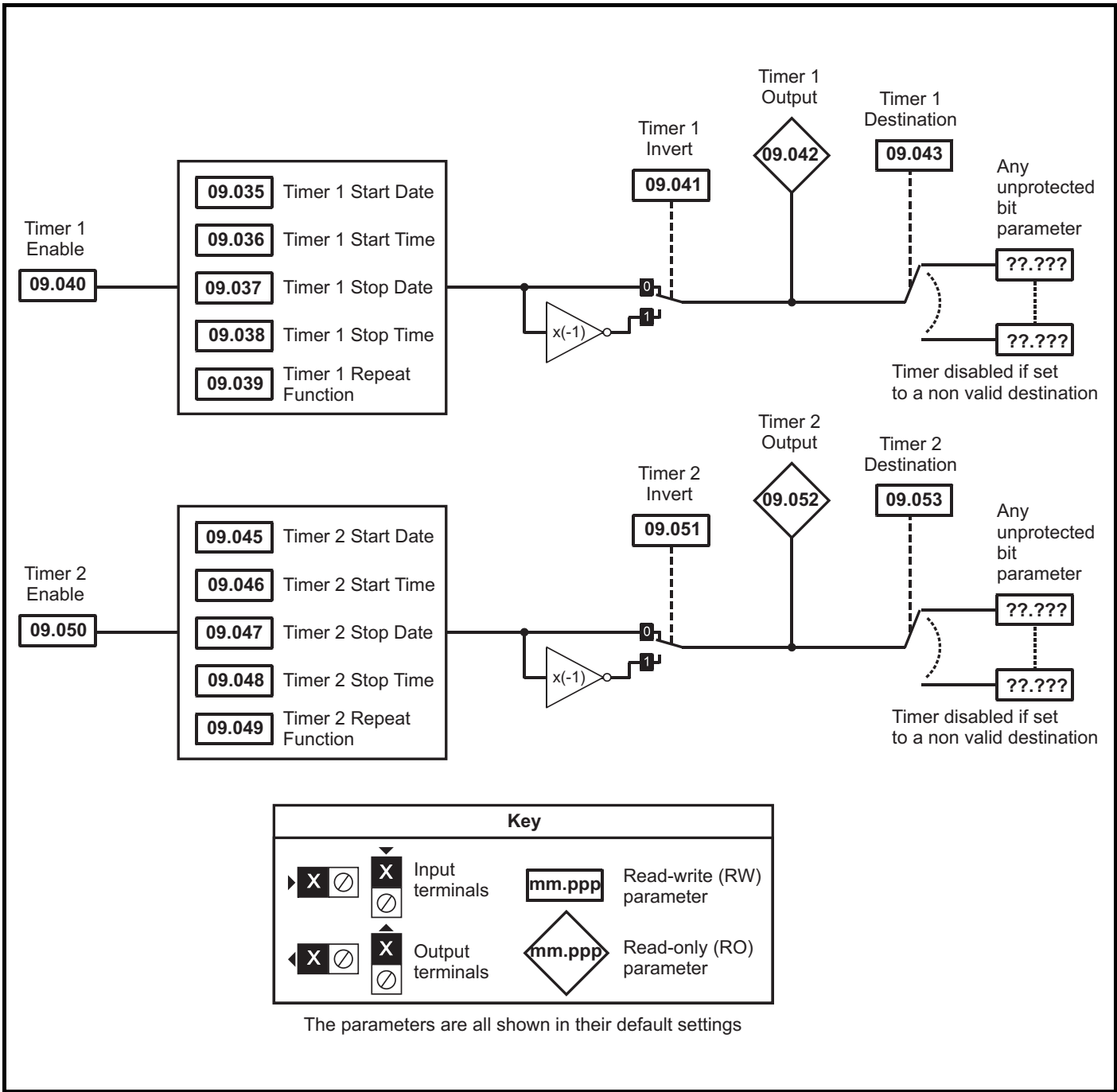
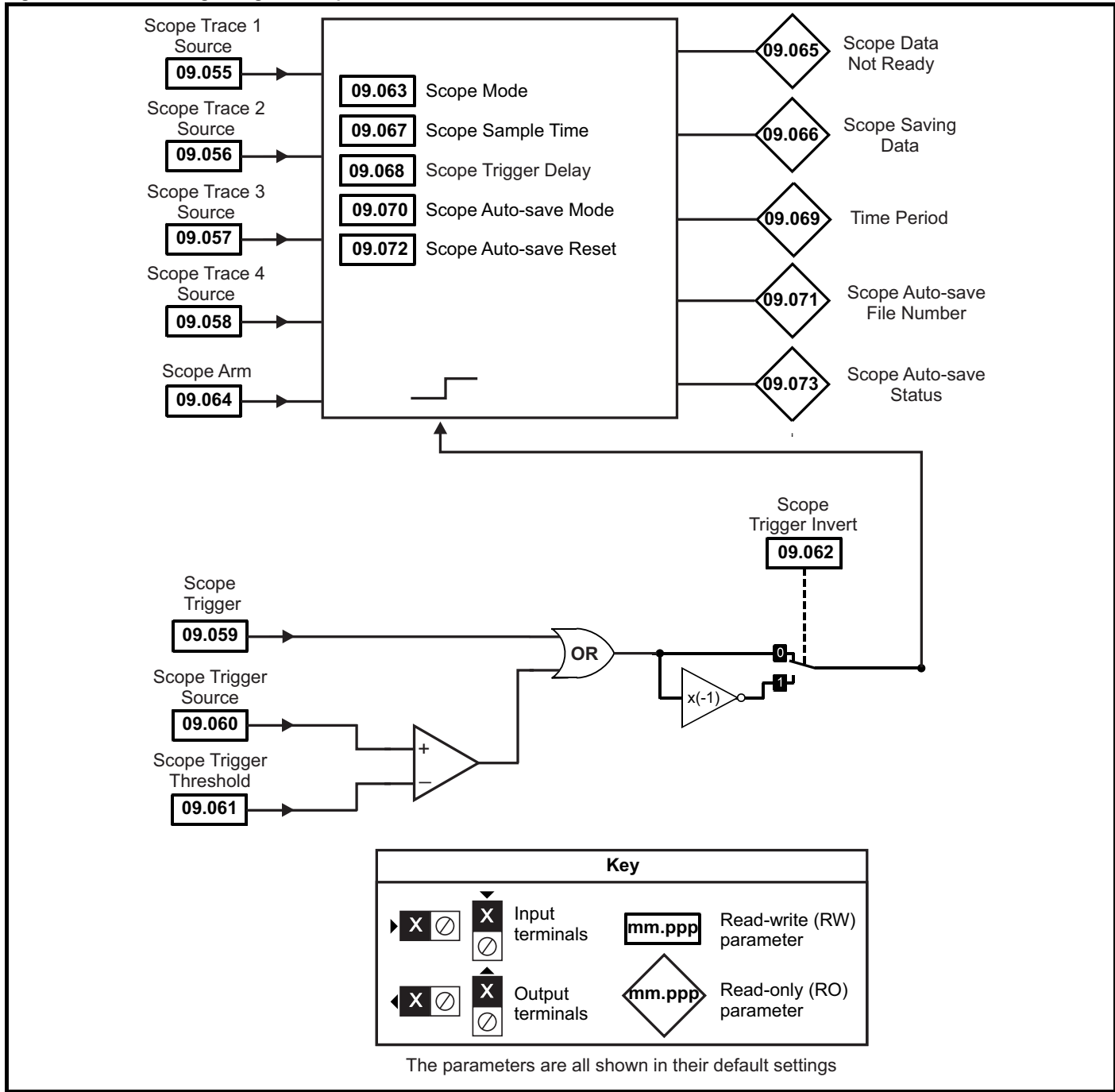

Figure 10-20 Menu 9 logic diagram: Timers



**Figure 10-21 Menu 9 logic diagram: Scope function**



Parameter		Range(⇄)		Default(⇒)			Type					
		OL	RFC-A / S	OL	RFC-A	RFC-S						
09.001	Logic Function 1 Output	Off (0) or On (1)					RO	Bit	ND	NC	PT	
09.002	Logic Function 2 Output	Off (0) or On (1)					RO	Bit	ND	NC	PT	
09.003	Motorized Pot Output	±100.00 %					RO	Num	ND	NC	PT	PS
09.004	Logic Function 1 Source 1	0.000 to 59.999		0.000			RW	DE			PT	US
09.005	Logic Function 1 Source 1 Invert	Off (0) or On (1)		Off (0)			RW	Bit				US
09.006	Logic Function 1 Source 2	0.000 to 59.999		0.000			RW	DE			PT	US
09.007	Logic Function 1 Source 2 Invert	Off (0) or On (1)		Off (0)			RW	Bit				US
09.008	Logic Function 1 Output Invert	Off (0) or On (1)		Off (0)			RW	Bit				US
09.009	Logic Function 1 Delay	±25.0 s		0.0 s			RW	Num				US
09.010	Logic Function 1 Destination	0.000 to 59.999		0.000			RW	DE			PT	US
09.014	Logic Function 2 Source 1	0.000 to 59.999		0.000			RW	Num			PT	US
09.015	Logic Function 2 Source 1 Invert	Off (0) or On (1)		Off (0)			RW	Bit				US
09.016	Logic Function 2 Source 2	0.000 to 59.999		0.000			RW	Num			PT	US
09.017	Logic Function 2 Source 2 Invert	Off (0) or On (1)		Off (0)			RW	Bit				US
09.018	Logic Function 2 Output Invert	Off (0) or On (1)		Off (0)			RW	Bit				US
09.019	Logic Function 2 Delay	±25.0 s		0.0 s			RW	Num				US
09.020	Logic Function 2 Destination	0.000 to 59.999		0.000			RW	DE			PT	US
09.021	Motorized Pot Mode	0 to 4		0			RW	Num				US
09.022	Motorized Pot Bipolar Select	Off (0) or On (1)		Off (0)			RW	Bit				US
09.023	Motorized Pot Rate	0 to 250 s		20 s			RW	Num				US
09.024	Motorized Pot Scaling	0.000 to 4.000		1.000			RW	Num				US
09.025	Motorized Pot Destination	0.000 to 59.999		0.000			RW	DE			PT	US
09.026	Motorized Pot Up	Off (0) or On (1)		Off (0)			RW	Bit		NC		
09.027	Motorized Pot Down	Off (0) or On (1)		Off (0)			RW	Bit		NC		
09.028	Motorized Pot Reset	Off (0) or On (1)		Off (0)			RW	Bit		NC		
09.029	Binary Sum Ones	Off (0) or On (1)		Off (0)			RW	Bit		NC		
09.030	Binary Sum Twos	Off (0) or On (1)		Off (0)			RW	Bit		NC		
09.031	Binary Sum Fours	Off (0) or On (1)		Off (0)			RW	Bit		NC		
09.032	Binary Sum Output	0 to 255					RO	Num	ND	NC	PT	
09.033	Binary Sum Destination	0.000 to 59.999		0.000			RW	DE			PT	US
09.034	Binary Sum Offset	0 to 248		0			RW	Num				US
09.035	Timer 1 Start Date	00-00-00 to 31-12-99		00-00-00			RW	Date				US
09.036	Timer 1 Start Time	00:00:00 to 23:59:59		00:00:00			RW	Time				US
09.037	Timer 1 Stop Date	00-00-00 to 31-12-99		00-00-00			RW	Date				US
09.038	Timer 1 Stop Time	00:00:00 to 23:59:59		00:00:00			RW	Time				US
09.039	Timer 1 Repeat Function	None (0), Hour (1), Day (2), Week (3), Month (4), Year (5), One off (6), Minute (7)		None (0)			RW	Txt				US
09.040	Timer 1 Enable	Off (0) or On (1)		Off (0)			RW	Bit				US
09.041	Timer 1 Invert	Off (0) or On (1)		Off (0)			RW	Bit				US
09.042	Timer 1 Output	Off (0) or On (1)					RO	Bit	ND	NC	PT	
09.043	Timer 1 Destination	0.000 to 59.999		0.000			RW	DE			PT	US
09.045	Timer 2 Start Date	00-00-00 to 31-12-99		00-00-00			RW	Date				US
09.046	Timer 2 Start Time	00:00:00 to 23:59:59		00:00:00			RW	Time				US
09.047	Timer 2 Stop Date	00-00-00 to 31-12-99		00-00-00			RW	Date				US
09.048	Timer 2 Stop Time	00:00:00 to 23:59:59		00:00:00			RW	Time				US
09.049	Timer 2 Repeat Function	None (0), Hour (1), Day (2), Week (3), Month (4), Year (5), One off (6), Minute (7)		None (0)			RW	Txt				US
09.050	Timer 2 Enable	Off (0) or On (1)		Off (0)			RW	Bit				US
09.051	Timer 2 Invert	Off (0) or On (1)		Off (0)			RW	Bit				US
09.052	Timer 2 Output	Off (0) or On (1)					RO	Bit	ND	NC	PT	
09.053	Timer 2 Destination	0.000 to 59.999		0.000			RW	DE			PT	US
09.055	Scope Trace 1 Source	0.000 to 59.999		0.000			RW	Num			PT	US
09.056	Scope Trace 2 Source	0.000 to 59.999		0.000			RW	Num			PT	US
09.057	Scope Trace 3 Source	0.000 to 59.999		0.000			RW	Num			PT	US
09.058	Scope Trace 4 Source	0.000 to 59.999		0.000			RW	Num			PT	US
09.059	Scope Trigger	Off (0) or On (1)		Off (0)			RW	Bit				
09.060	Scope Trigger Source	0.000 to 59.999		0.000			RW	Num			PT	US
09.061	Scope Trigger Threshold	-2147483648 to 2147483647		0			RW	Num				US

Parameter		Range(⇅)		Default(⇄)			Type					
		OL	RFC-A / S	OL	RFC-A	RFC-S						
09.062	Scope Trigger Invert	Off (0) or On (1)		Off (0)			RW	Bit				US
09.063	Scope Mode	Single (0), Normal (1), Auto (2)		Single (0)			RW	Txt				US
09.064	Scope Arm	Off (0) or On (1)		Off (0)			RW	Bit		NC		
09.065	Scope Data Not Ready	Off (0) or On (1)					RO	Bit	ND	NC	PT	
09.066	Scope Saving Data	Off (0) or On (1)					RO	Bit	ND	NC	PT	
09.067	Scope Sample Time	1 to 200		1			RW	Num				US
09.068	Scope Trigger Delay	0 to 100 %		0 %			RW	Num				US
09.069	Scope Time Period	0.00 to 200000.00 ms					RO	Num	ND	NC	PT	
09.070	Scope Auto-save Mode	Disabled (0), Overwrite (1), Keep (2)					Disabled (0)			RW	Txt	
09.071	Scope Auto-save File Number	0 to 99		0			RO	Num				PS
09.072	Scope Auto-save Reset	Off (0) or On (1)		Off (0)			RW	Bit				
09.073	Scope Auto-save Status	Disabled (0), Active (1), Stopped (2), Failed (3)		Disabled (0)			RO	Txt				PS

RW	Read / Write	RO	Read only	Num	Number parameter	Bit	Bit parameter	Txt	Text string	Bin	Binary parameter	FI	Filtered
ND	No default value	NC	Not copied	PT	Protected parameter	RA	Rating dependent	US	User save	PS	Power-down save	DE	Destination
IP	IP address	Mac	Mac address	Date	Date parameter	Time	Time parameter	SMP	Slot,menu,parameter	Chr	Character parameter	Ver	Version number

## 10.11 Menu 10: Status and trips

Parameter		Range(↕)		Default(⇔)			Type					
		OL	RFC-A / S	OL	RFC-A	RFC-S	RO	Bit	ND	NC	PT	
10.001	Drive Healthy		Off (0) or On (1)				RO	Bit	ND	NC	PT	
10.002	Drive Active		Off (0) or On (1)				RO	Bit	ND	NC	PT	
10.003	Zero Speed		Off (0) or On (1)				RO	Bit	ND	NC	PT	
10.004	Running At Or Below Minimum Speed		Off (0) or On (1)				RO	Bit	ND	NC	PT	
10.005	Below Set Speed		Off (0) or On (1)				RO	Bit	ND	NC	PT	
10.006	At Speed		Off (0) or On (1)				RO	Bit	ND	NC	PT	
10.007	Above Set Speed		Off (0) or On (1)				RO	Bit	ND	NC	PT	
10.008	Rated Load Reached		Off (0) or On (1)				RO	Bit	ND	NC	PT	
10.009	Current Limit Active		Off (0) or On (1)				RO	Bit	ND	NC	PT	
10.010	Regenerating		Off (0) or On (1)				RO	Bit	ND	NC	PT	
10.011	Braking IGBT Active		Off (0) or On (1)				RO	Bit	ND	NC	PT	
10.012	Braking Resistor Alarm		Off (0) or On (1)				RO	Bit	ND	NC	PT	
10.013	Reverse Direction Commanded		Off (0) or On (1)				RO	Bit	ND	NC	PT	
10.014	Reverse Direction Running		Off (0) or On (1)				RO	Bit	ND	NC	PT	
10.015	Supply Loss		Off (0) or On (1)				RO	Bit	ND	NC	PT	
10.016	Under Voltage Active		Off (0) or On (1)				RO	Bit	ND	NC	PT	
10.017	Motor Overload Alarm		Off (0) or On (1)				RO	Bit	ND	NC	PT	
10.018	Drive Over-temperature Alarm		Off (0) or On (1)				RO	Bit	ND	NC	PT	
10.019	Drive Warning		Off (0) or On (1)				RO	Bit	ND	NC	PT	
10.020	Trip 0		0 to 255				RO	Txt	ND	NC	PT	PS
10.021	Trip 1		0 to 255				RO	Txt	ND	NC	PT	PS
10.022	Trip 2		0 to 255				RO	Txt	ND	NC	PT	PS
10.023	Trip 3		0 to 255				RO	Txt	ND	NC	PT	PS
10.024	Trip 4		0 to 255				RO	Txt	ND	NC	PT	PS
10.025	Trip 5		0 to 255				RO	Txt	ND	NC	PT	PS
10.026	Trip 6		0 to 255				RO	Txt	ND	NC	PT	PS
10.027	Trip 7		0 to 255				RO	Txt	ND	NC	PT	PS
10.028	Trip 8		0 to 255				RO	Txt	ND	NC	PT	PS
10.029	Trip 9		0 to 255				RO	Txt	ND	NC	PT	PS
10.030	Braking Resistor Rated Power	0.000 to 99999.999 kW		See Table 10-5			RW	Num				US
10.031	Braking Resistor Thermal Time Constant	0.000 to 1500.000 s		See Table 10-5			RW	Num				US
10.032	External Trip	Off (0) or On (1)		Off (0)			RW	Bit		NC		
10.033	Drive Reset	Off (0) or On (1)		Off (0)			RW	Bit		NC		
10.034	Number Of Auto-reset Attempts	None (0), 1, 2, 3, 4, 5, Infinite (6)		None (0)			RW	Txt				US
10.035	Auto-reset Delay	1.0 to 600.0 s		1.0 s			RW	Num				US
10.036	Auto-reset Hold Drive Healthy	Off (0) or On (1)		Off (0)			RW	Bit				US
10.037	Action On Trip Detection	00000 to 11111		00000			RW	Bin				US
10.038	User Trip	0 to 255		0			RW	Num	ND	NC		
10.039	Braking Resistor Thermal Accumulator	0.0 to 100.0 %					RO	Num	ND	NC	PT	
10.040	Status Word	0000000000000000 to 1111111111111111					RO	Bin	ND	NC	PT	
10.041	Trip 0 Date	00-00-00 to 31-12-99					RO	Date	ND	NC	PT	PS
10.042	Trip 0 Time	00:00:00 to 23:59:59					RO	Time	ND	NC	PT	PS
10.043	Trip 1 Date	00-00-00 to 31-12-99					RO	Date	ND	NC	PT	PS
10.044	Trip 1 Time	00:00:00 to 23:59:59					RO	Time	ND	NC	PT	PS
10.045	Trip 2 Date	00-00-00 to 31-12-99					RO	Date	ND	NC	PT	PS
10.046	Trip 2 Time	00:00:00 to 23:59:59					RO	Time	ND	NC	PT	PS
10.047	Trip 3 Date	00-00-00 to 31-12-99					RO	Date	ND	NC	PT	PS
10.048	Trip 3 Time	00:00:00 to 23:59:59					RO	Time	ND	NC	PT	PS
10.049	Trip 4 Date	00-00-00 to 31-12-99					RO	Date	ND	NC	PT	PS
10.050	Trip 4 Time	00:00:00 to 23:59:59					RO	Time	ND	NC	PT	PS
10.051	Trip 5 Date	00-00-00 to 31-12-99					RO	Date	ND	NC	PT	PS
10.052	Trip 5 Time	00:00:00 to 23:59:59					RO	Time	ND	NC	PT	PS
10.053	Trip 6 Date	00-00-00 to 31-12-99					RO	Date	ND	NC	PT	PS

Parameter		Range(⇅)		Default(⇄)			Type								
		OL	RFC-A / S	OL	RFC-A	RFC-S									
10.054	Trip 6 Time	00:00:00 to 23:59:59		See Table 10-5			RO	Time	ND	NC	PT	PS			
10.055	Trip 7 Date	00-00-00 to 31-12-99					RO	Date	ND	NC	PT	PS			
10.056	Trip 7 Time	00:00:00 to 23:59:59					RO	Time	ND	NC	PT	PS			
10.057	Trip 8 Date	00-00-00 to 31-12-99					RO	Date	ND	NC	PT	PS			
10.058	Trip 8 Time	00:00:00 to 23:59:59					RO	Time	ND	NC	PT	PS			
10.059	Trip 9 Date	00-00-00 to 31-12-99					RO	Date	ND	NC	PT	PS			
10.060	Trip 9 Time	00:00:00 to 23:59:59					RO	Time	ND	NC	PT	PS			
10.061	Braking Resistor Resistance	0.00 to 10000.00 Ω					See Table 10-5			RW	Num				US
10.062	Low Load Detected Alarm	Off (0) or On (1)					Off (0)			RO	Bit	ND	NC	PT	
10.063	Local Keypad Battery Low	Off (0) or On (1)								RO	Bit	ND	NC	PT	
10.064	Remote Keypad Battery Low	Off (0) or On (1)		RO	Bit	ND				NC	PT				
10.065	Auto-tune Active	Off (0) or On (1)		RO	Bit	ND				NC	PT				
10.066	Limit Switch Active	Off (0) or On (1)		RO	Bit	ND				NC	PT				
10.068	Hold Drive Healthy On Under Voltage	Off (0) or On (1)		Off (0)			RW	Bit				US			
10.069	Additional Status Bits	0000000000 to 1111111111		Off (0)			RO	Bin	ND	NC	PT				
10.070	Trip 0 Sub-trip Number	0 to 65535					RO	Num	ND	NC	PT	PS			
10.071	Trip 1 Sub-trip Number	0 to 65535					RO	Num	ND	NC	PT	PS			
10.072	Trip 2 Sub-trip Number	0 to 65535					RO	Num	ND	NC	PT	PS			
10.073	Trip 3 Sub-trip Number	0 to 65535					RO	Num	ND	NC	PT	PS			
10.074	Trip 4 Sub-trip Number	0 to 65535					RO	Num	ND	NC	PT	PS			
10.075	Trip 5 Sub-trip Number	0 to 65535					RO	Num	ND	NC	PT	PS			
10.076	Trip 6 Sub-trip Number	0 to 65535					RO	Num	ND	NC	PT	PS			
10.077	Trip 7 Sub-trip Number	0 to 65535					RO	Num	ND	NC	PT	PS			
10.078	Trip 8 Sub-trip Number	0 to 65535					RO	Num	ND	NC	PT	PS			
10.079	Trip 9 Sub-trip Number	0 to 65535					RO	Num	ND	NC	PT	PS			
10.080	Stop Motor	Off (0) or On (1)					RO	Bit	ND	NC	PT				
10.081	Phase Loss	Off (0) or On (1)					RO	Bit	ND	NC	PT				
10.101	Drive Status	Inhibit (0), Ready (1), Stop (2), Scan (3), Run (4), Supply Loss (5), Deceleration (6), dc Injection (7), Position (8), Trip (9), Active (10), Off (11), Hand (12), Auto (13), Heat (14), Under Voltage (15), Phasing (16)					RO	Txt	ND	NC	PT				
10.102	Trip Reset Source	0 to 1023					RO	Num	ND	NC	PT	PS			
10.103	Trip Time Identifier	-2147483648 to 2147483647 ms		RO	Num	ND	NC	PT							
10.104	Active Alarm	None (0), Brake Resistor (1), Motor Overload (2), Ind Overload (3), Drive Overload (4), Auto Tune (5), Limit Switch (6), Fire Mode (7), Low Load (8), Option Slot 1 (9), Option Slot 2 (10), Option Slot 3 (11), Option Slot 4 (12)		RO	Txt	ND	NC	PT							
10.106	Potential Drive Damage Conditions	0000 to 1111		RO	Bin	ND	NC	PT	PS						

RW	Read / Write	RO	Read only	Num	Number parameter	Bit	Bit parameter	Txt	Text string	Bin	Binary parameter	FI	Filtered
ND	No default value	NC	Not copied	PT	Protected parameter	RA	Rating dependent	US	User save	PS	Power-down save	DE	Destination
IP	IP address	Mac	Mac address	Date	Date parameter	Time	Time parameter	SMP	Slot,menu,parameter	Chr	Character parameter	Ver	Version number

Table 10-5 Defaults for Pr 10.030, Pr 10.031 and Pr 10.061

Drive size	Pr 10.030	Pr 10.031	Pr 10.061
3	50 W	3.3 s	75 Ω
4 and 5	100 W	2.0 s	38 Ω
All other ratings and frame sizes	0.000		0.00

## 10.12 Menu 11: General drive set-up

Parameter		Range(⇅)		Default(⇄)			Type						
		OL	RFC-A / S	OL	RFC-A	RFC-S							
11.001	Option Synchronisation Select	Not Active (0), Slot 1 (1), Slot 2 (2), Slot 3 (3), Slot 4 (4), Automatic (5)		Slot 4 (4)			RW	Txt					US
11.002	Option synchronisation Active	Not Active (0), Slot 1 (1), Slot 2 (2), Slot 3 (3), Slot 4 (4)					RO	Txt	ND	NC	PT		
11.018	Status Mode Parameter 1	0.000 to 59.999		0.000			RW	Num				PT	US
11.019	Status Mode Parameter 2	0.000 to 59.999		0.000			RW	Num				PT	US
11.020	Reset Serial Communications	Off (0) or On (1)		Off (0)			RW	Bit	ND	NC			
11.021	Parameter 00.030 Scaling	0.000 to 10.000		1.000			RW	Num					US
11.022	Parameter Displayed At Power-up	0.000 to 0.080		0.010			RW	Num				PT	US
11.023	Serial Address	1 to 247		1			RW	Num					US
11.024	Serial Mode	8 2 NP (0), 8 1 NP (1), 8 1 EP (2), 8 1 OP (3), 8 2 NP M (4), 8 1 NP M (5), 8 1 EP M (6), 8 1 OP M (7), 7 2 NP (8), 7 1 NP (9), 7 1 EP (10), 7 1 OP (11), 7 2 NP M (12), 7 1 NP M (13), 7 1 EP M (14), 7 1 OP M (15)		8 2 NP (0)			RW	Txt					US
11.025	Serial Baud Rate	300 (0), 600 (1), 1200 (2), 2400 (3), 4800 (4), 9600 (5), 19200 (6), 38400 (7), 57600 (8), 76800 (9), 115200 (10)		19200 (6)			RW	Txt					US
11.026	Minimum Comms Transmit Delay	0 to 250 ms		2 ms			RW	Num					US
11.027	Silent Period	0 to 250 ms		0 ms			RW	Num					US
11.028	Drive Derivative	0 to 255					RO	Num	ND	NC	PT		
11.029	Software Version	00.00.00.00 to 99.99.99.99					RO	Num	ND	NC	PT		
11.030	User Security Code	0 to 2147483647		0			RW	Num	ND	NC	PT	US	
11.031	User Drive Mode	Open-loop (1), RFC-A (2), RFC-S (3), Regen (4)		Open-loop (1)	RFC-A (2)	RFC-S (3)	RW	Txt	ND	NC	PT		
11.032	Maximum Heavy Duty Rating	0.000 to 99999.999 A					RO	Num	ND	NC	PT		
11.033	Drive Rated Voltage	200 V (0), 400 V (1), 575 V (2), 690 V (3)					RO	Txt	ND	NC	PT		
11.034	Software Sub-version	0 to 99					RO	Num	ND	NC	PT		
11.035	Number Of Power Modules Test	-1 to 20		-1			RW	Num					US
11.036	NV Media Card File Previously Loaded	0 to 999					RO	Num		NC	PT		
11.037	NV Media Card File Number	0 to 999		0			RW	Num					
11.038	NV Media Card File Type	None (0), Open-loop (1), RFC-A (2), RFC-S (3), Regen (4), User Prog (5), Option App (6)					RO	Txt	ND	NC	PT		
11.039	NV Media Card File Version	0 to 9999					RO	Num	ND	NC	PT		
11.040	NV Media Card File Checksum	-2147483648 to 2147483647					RO	Num	ND	NC	PT		
11.042	Parameter Cloning	None (0), Read (1), Program (2), Auto (3), Boot (4)		None (0)			RW	Txt		NC			US
11.043	Load Defaults	None (0), Standard (1), US (2)					RW	Txt		NC			
11.044	User Security Status	Menu 0 (0), All Menus (1), Read-only Menu 0 (2), Read-only (3), Status Only (4), No Access (5)		Menu 0 (0)			RW	Txt	ND			PT	
11.045	Select Motor 2 Parameters	Motor 1 (0) or Motor 2 (1)		Motor 1 (0)			RW	Txt					US
11.046	Defaults Previously Loaded	0 to 2000					RO	Num	ND	NC	PT	US	
11.047	Onboard User Program: Enable	Stop (0) or Run (1)		Run (1)			RW	Txt					US
11.048	Onboard User Program: Status	-2147483648 to 2147483647					RO	Num	ND	NC	PT		
11.049	Onboard User Program: Programming Events	0 to 65535					RO	Num	ND	NC	PT		
11.050	Onboard User Program: Freewheeling Tasks Per Second	0 to 65535					RO	Num	ND	NC	PT		
11.051	Onboard User Program: Clock Task Time Used	0.0 to 100.0 %					RO	Num	ND	NC	PT		
11.052	Serial Number LS	000000000 to 999999999					RO	Num	ND	NC	PT		
11.053	Serial Number MS	0 to 999999999					RO	Num	ND	NC	PT		
11.054	Drive Date Code	0 to 65535					RO	Num	ND	NC	PT		
11.055	Onboard User Program: Clock Task Scheduled Interval	0 to 262140 ms					RO	Num	ND	NC	PT		
11.056	Option Slot Identifiers	1234 (0), 1243 (1), 1324 (2), 1342 (3), 1423 (4), 1432 (5), 4123 (6), 3124 (7), 4132 (8), 2134 (9), 3142 (10), 2143 (11), 3412 (12), 4312 (13), 2413 (14), 4213 (15), 2314 (16), 3214 (17), 2341 (18), 2431 (19), 3241 (20), 3421 (21), 4231 (22), 4321 (23)		1234 (0)			RW	Txt				PT	
11.060	Maximum Rated Current	0.000 to 99999.999 A					RO	Num	ND	NC	PT		
11.061	Full Scale Current Kc	0.000 to 99999.999 A					RO	Num	ND	NC	PT		
11.062	Power Board Software Version Number	0.00 to 99.99					RO	Num	ND	NC	PT		
11.063	Product Type	0 to 255					RO	Num	ND	NC	PT		

Parameter	Range(⌘)		Default(⇒)			Type					
	OL	RFC-A / S	OL	RFC-A	RFC-S	RO	Chr	ND	NC	PT	US
11.064	Product Identifier Characters	M600	M600			RO	Chr	ND	NC	PT	
11.065	Drive Rating And Configuration	00000000 to 99999999				RO	Num	ND	NC	PT	
11.066	Power Stage Identifier	0 to 255				RO	Num	ND	NC	PT	
11.067	Control Board Identifier	0.000 to 65.535				RO	Num	ND	NC	PT	
11.068	Internal I/O Identifier	0 to 255				RO	Num	ND	NC	PT	
11.069	Position Feedback Interface Identifier	0 to 255				RO	Num	ND	NC	PT	
11.070	Core Parameter Database Version	0.00 to 99.99				RO	Num	ND	NC	PT	
11.071	Number Of Power Modules Detected	0 to 20				RO	Num	ND	NC	PT	US
11.072	NV Media Card Create Special File	0 to 1	0			RW	Num		NC		
11.073	NV Media Card Type	None (0), SMARTCARD (1), SD Card (2)				RO	Num	ND	NC	PT	
11.075	NV Media Card Read-only Flag	Off (0) or On (1)				RO	Bit	ND	NC	PT	
11.076	NV Media Card Warning Suppression Flag	Off (0) or On (1)				RO	Bit	ND	NC	PT	
11.077	NV Media Card File Required Version	0 to 9999	0			RW	Num	ND	NC	PT	
11.079	Drive Name Characters 1-4	----(2147483648) to ----(2147483647)	----(0)			RW	Chr			PT	US
11.080	Drive Name Characters 5-8	----(2147483648) to ----(2147483647)	----(0)			RW	Chr			PT	US
11.081	Drive Name Characters 9-12	----(2147483648) to ----(2147483647)	----(0)			RW	Chr			PT	US
11.082	Drive Name Characters 13-16	----(2147483648) to ----(2147483647)	----(0)			RW	Chr			PT	US
11.084	Drive Mode	Open-loop (1), RFC-A (2), RFC-S (3), Regen (4)				RO	Txt	ND	NC	PT	US
11.085	Security Status	None (0), Read-only (1), Status-only (2), No Access (3)				RO	Txt	ND	NC	PT	PS
11.086	Menu Access Status	Menu 0 (0) or All Menus (1)				RO	Txt	ND	NC	PT	PS
11.090	Keypad Port Serial Address	1 to 16	1			RW	Num				US
11.091	Product Identifier Characters 1	----(2147483648) to ----(2147483647)				RO	Chr	ND	NC	PT	
11.092	Product Identifier Characters 2	----(2147483648) to ----(2147483647)				RO	Chr	ND	NC	PT	
11.093	Product Identifier Characters 3	----(2147483648) to ----(2147483647)				RO	Chr	ND	NC	PT	
11.095	Number Of Rectifiers Detected	0 to 9				RO	Num	ND	NC	PT	
11.096	Number Of Rectifiers Expected	0 to 9	0			RW	Num				US

RW	Read / Write	RO	Read only	Num	Number parameter	Bit	Bit parameter	Txt	Text string	Bin	Binary parameter	Fl	Filtered
ND	No default value	NC	Not copied	PT	Protected parameter	RA	Rating dependent	US	User save	PS	Power-down save	DE	Destination
IP	IP address	Mac	Mac address	Date	Date parameter	Time	Time parameter	SMP	Slot,menu,parameter	Chr	Character parameter	Ver	Version number

## 10.13 Menu 12: Threshold detectors, variable selectors and brake control function

Figure 10-22 Menu 12 logic diagram

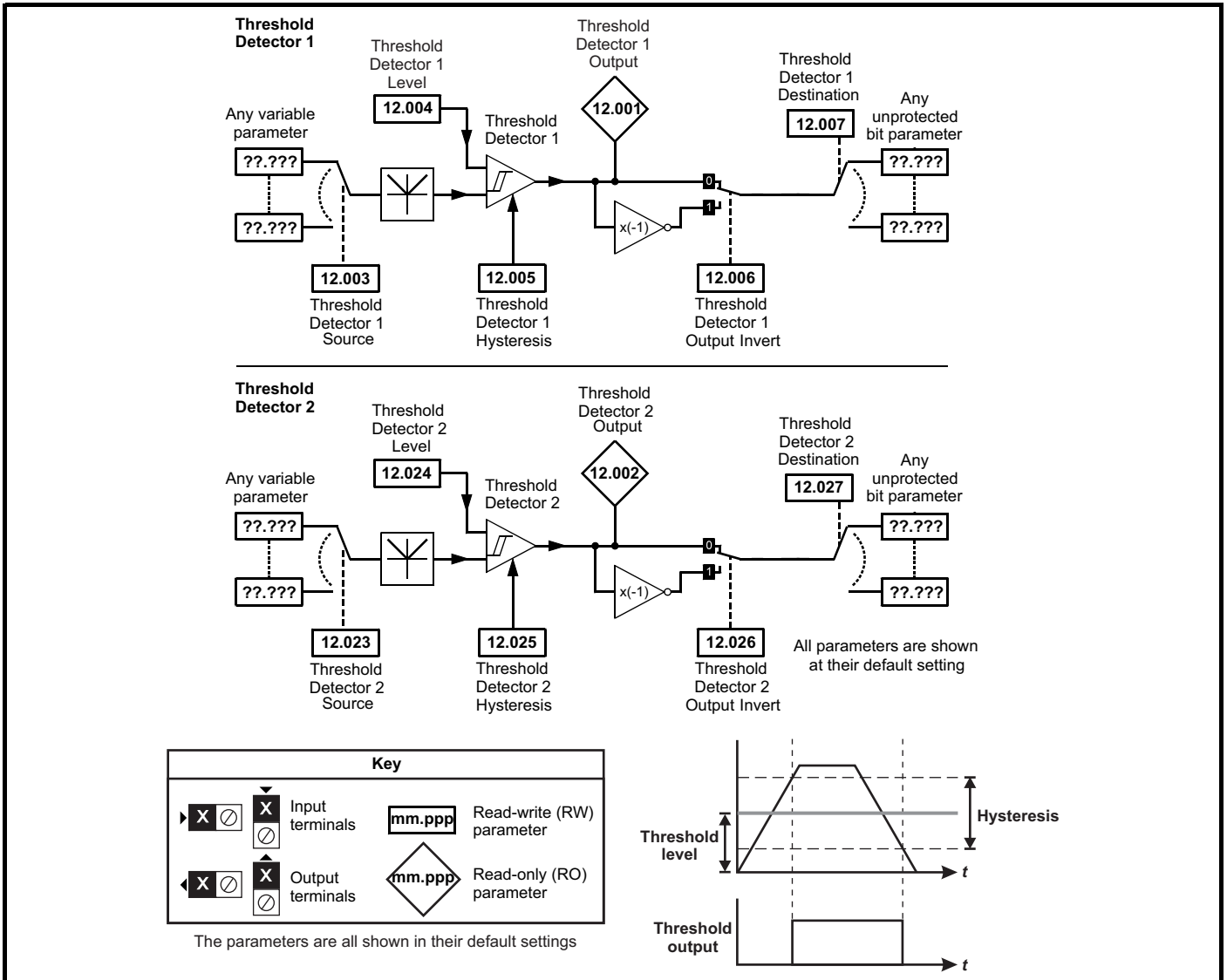

**Figure 10-23 Menu 12 logic diagram (continued)**

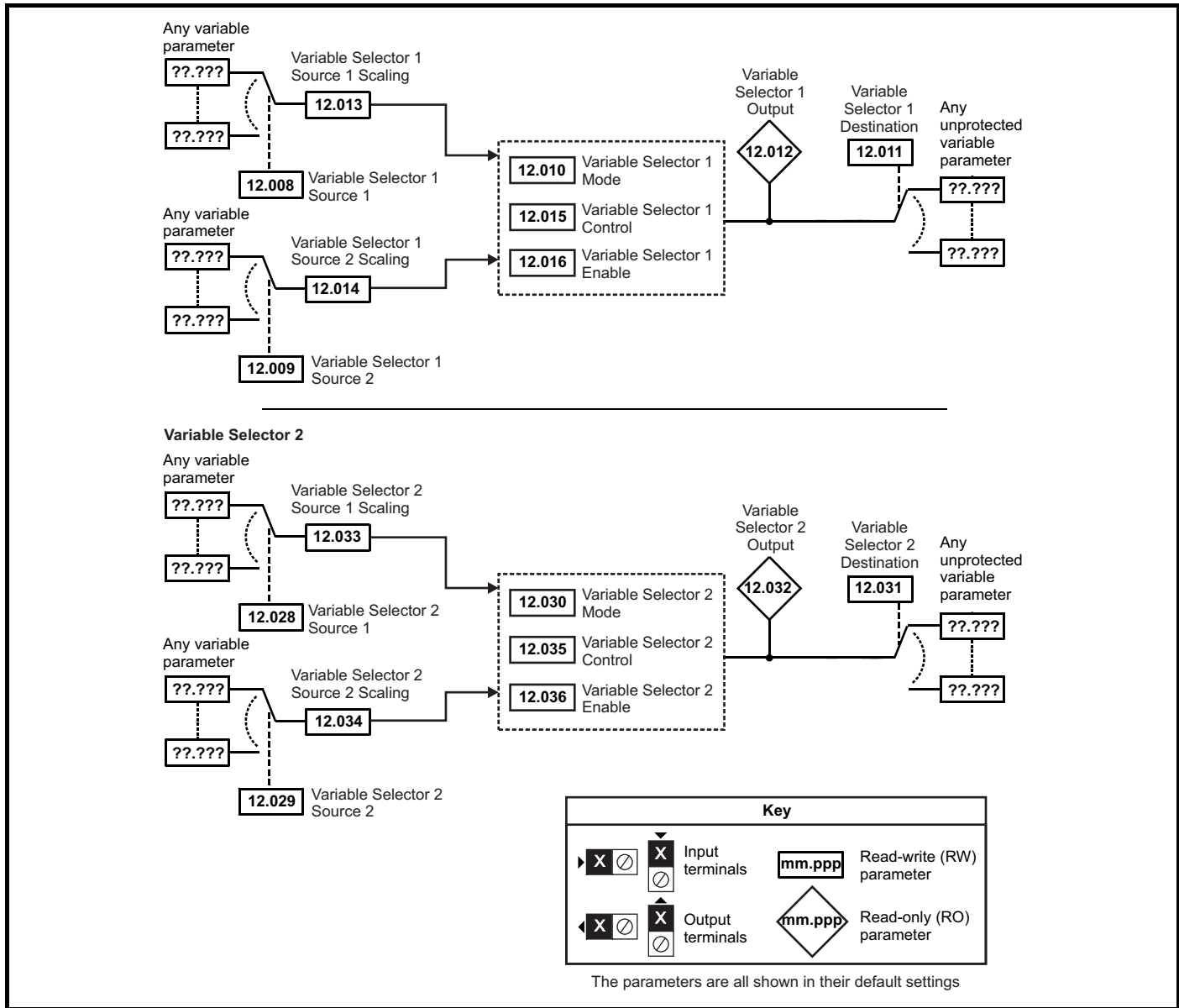



The brake control functions are provided to allow well co-ordinated operation of an external brake with the drive. While both hardware and software are designed to high standards of quality and robustness, they are not intended for use as safety functions, i.e. where a fault or failure would result in a risk of injury. In any application where the incorrect operation of the brake release mechanism could result in injury, independent protection devices of proven integrity must also be incorporated.



The control terminal relay can be selected as an output to release a brake. If a drive is set up in this manner and a drive replacement takes place, prior to programming the drive on initial power up, the brake may be released. When drive terminals are programmed to non default settings the result of incorrect or delayed programming must be considered. The use of a NV media card in boot mode can ensure drive parameters are immediately programmed to avoid this situation.

**Figure 10-24 Open-loop brake function**

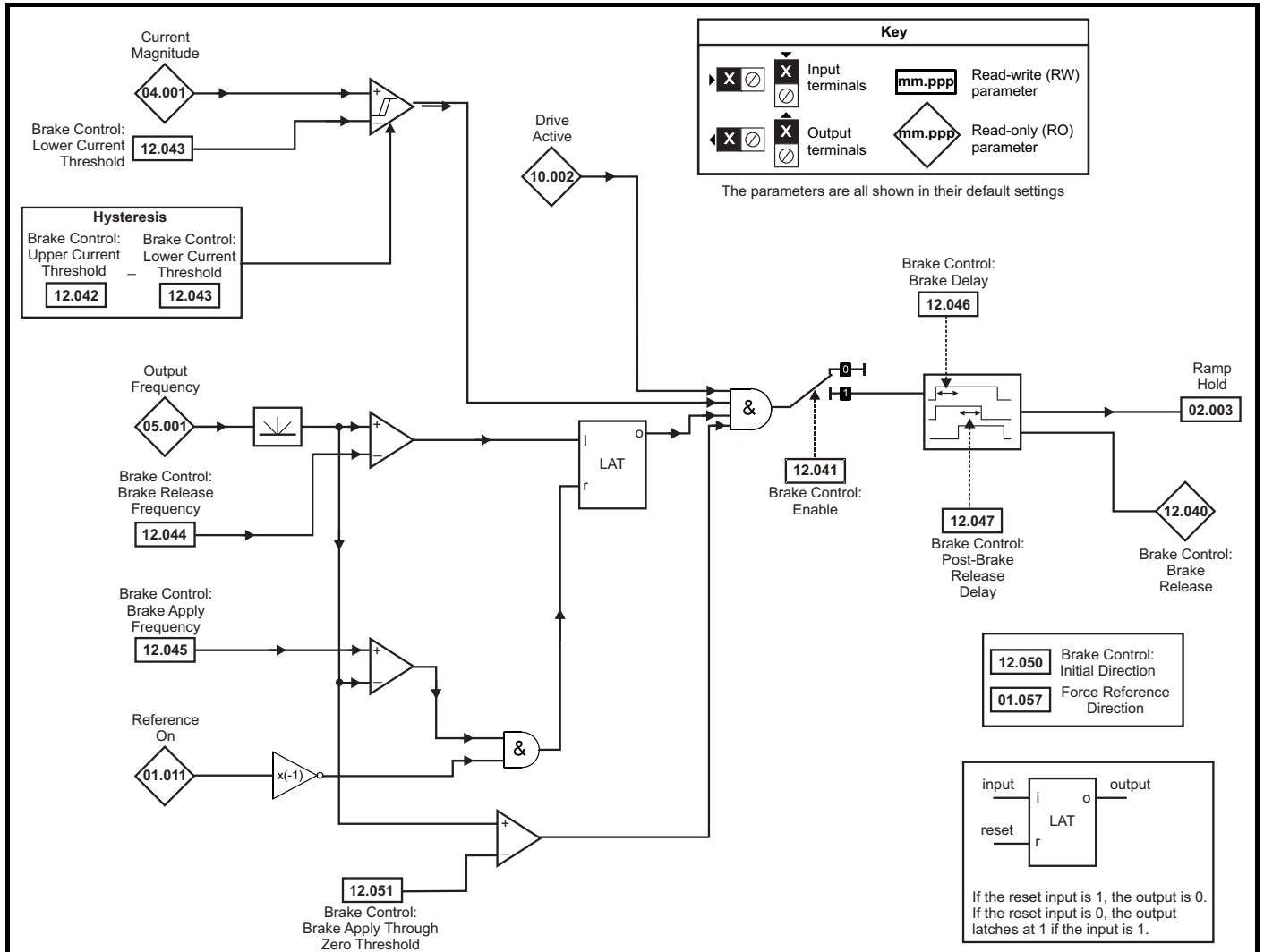

**Figure 10-25 Open-loop brake sequence**

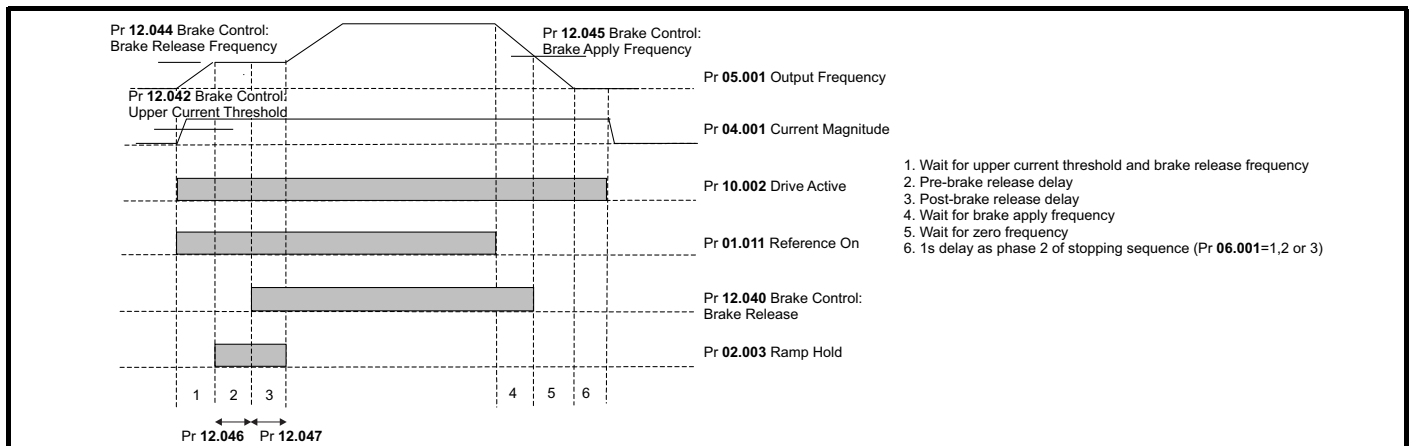

**Figure 10-26 RFC-A mode with brake controller mode (12.052) =1 (RFC-A Sensorless mode)**

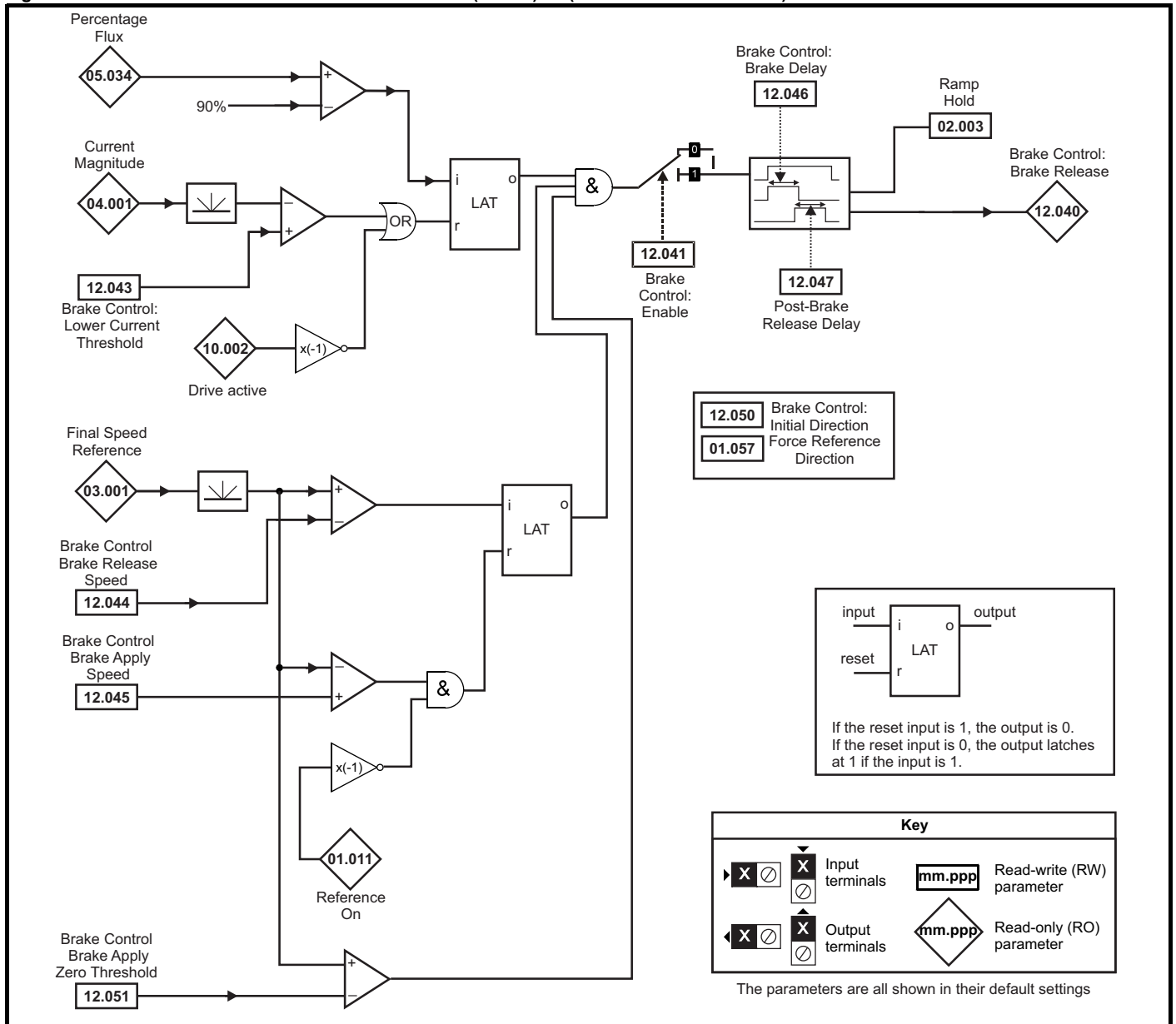

**Figure 10-27 RFC-A sensorless brake sequence**

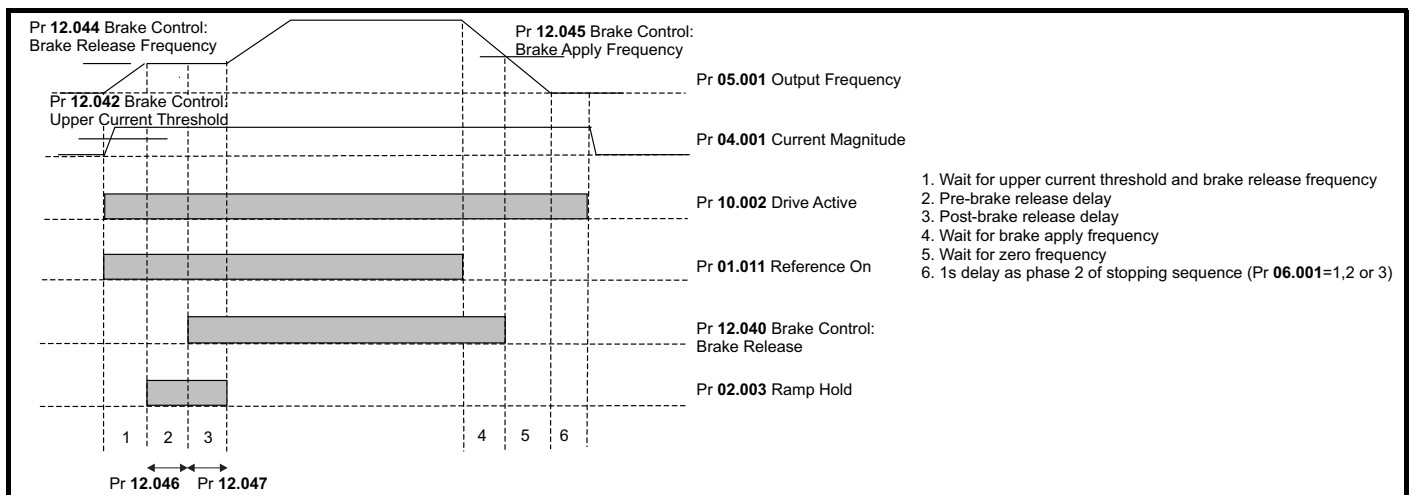

**Figure 10-28 RFC-A mode with brake controller mode (12.052) =0 (RFC-A with position feedback mode)**

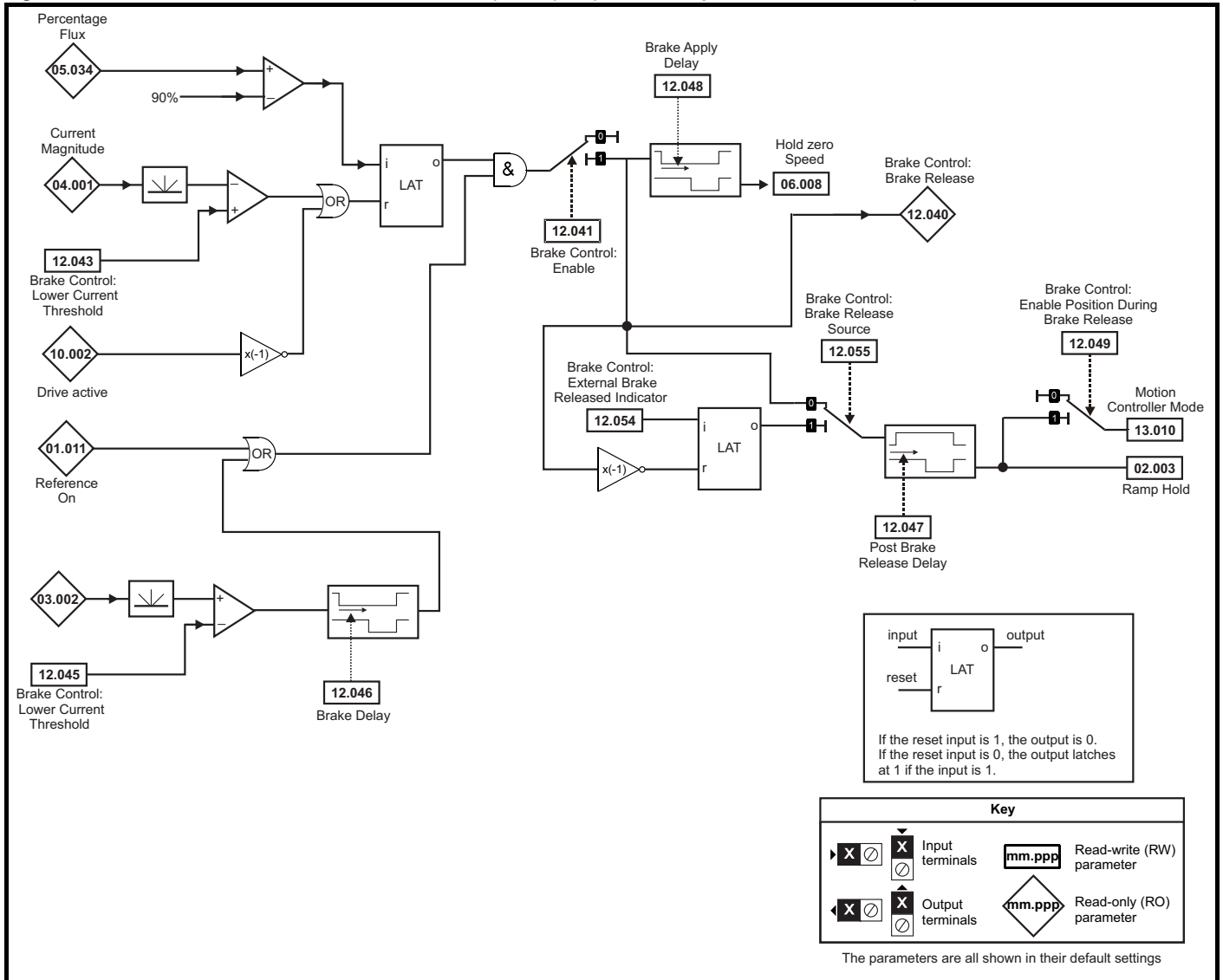

**Figure 10-29 RFC-A with position feedback brake sequence**

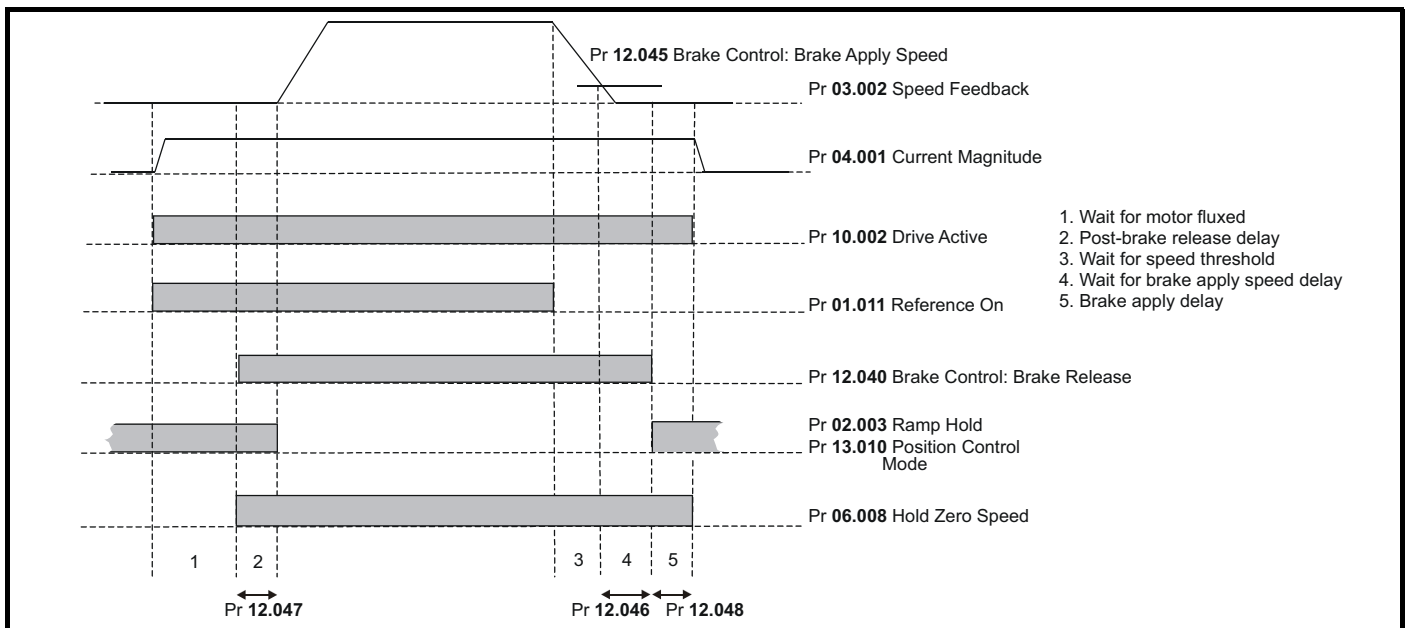

**Figure 10-30 RFC-S brake function**

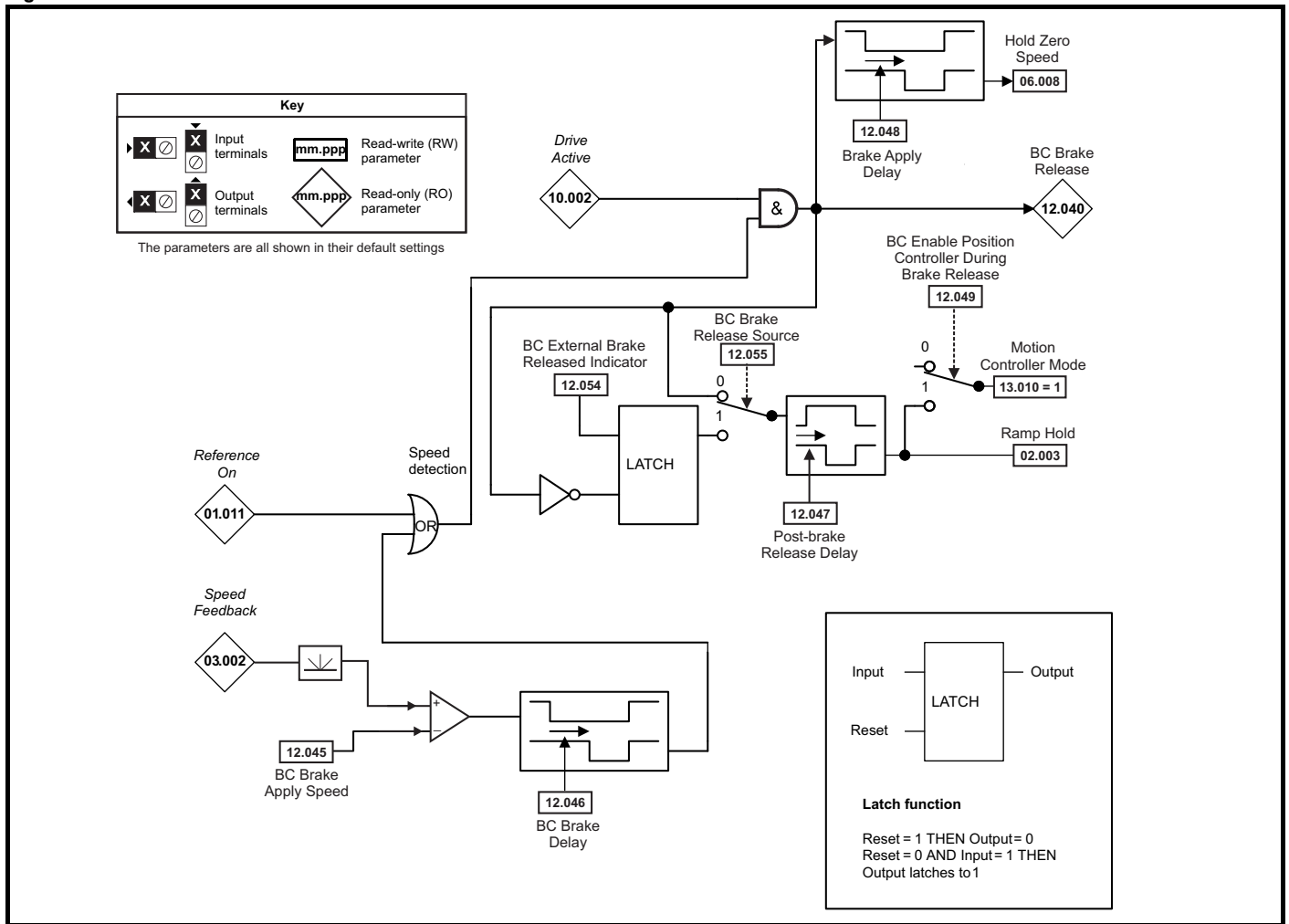

**NOTE**

RFC-S sensorless mode is only suitable for use with the brake function when *RFC Low speed mode* Pr 05.064 = (0) Injection

**Figure 10-31 RFC-S brake sequence**

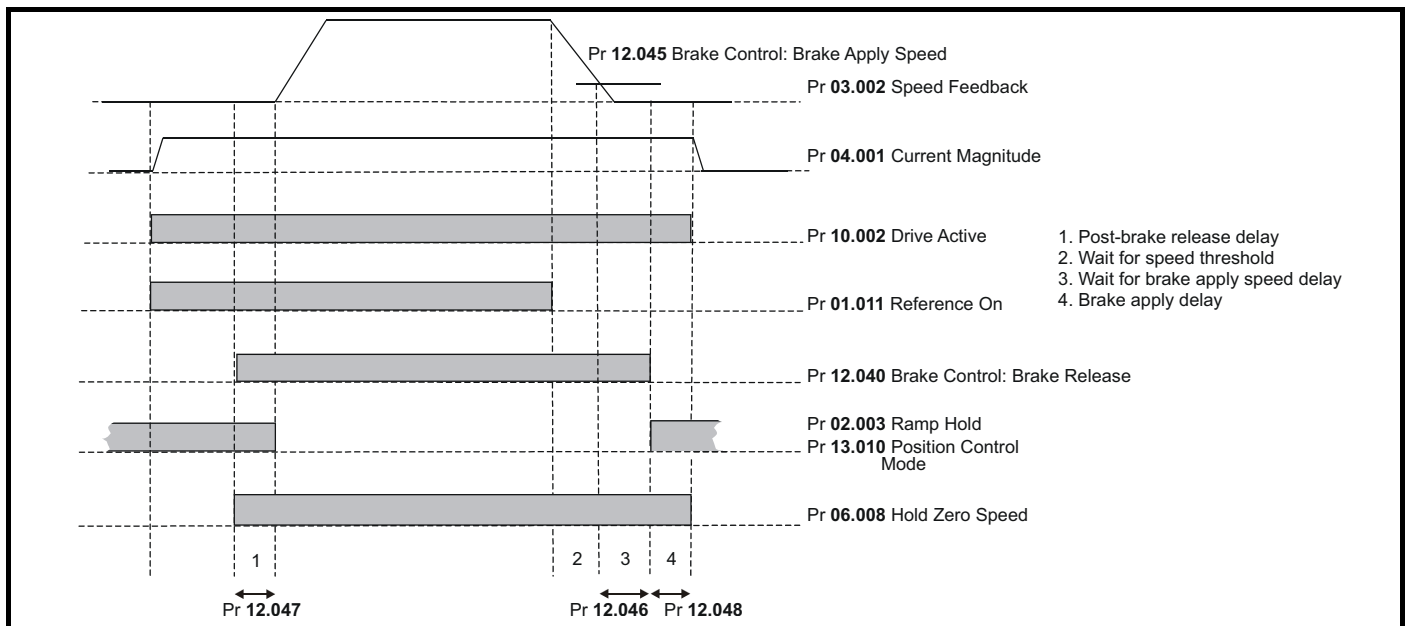

Parameter		Range(⇅)		Default(⇄)			Type					
		OL	RFC- A / S	OL	RFC-A	RFC-S	RO	Bit	ND	NC	PT	US
12.001	Threshold Detector 1 Output	Off (0) or On (1)					RO	Bit	ND	NC	PT	
12.002	Threshold Detector 2 Output	Off (0) or On (1)					RO	Bit	ND	NC	PT	
12.003	Threshold Detector 1 Source	0.000 to 59.999				0.000	RW	Num			PT	US
12.004	Threshold Detector 1 Level	0.00 to 100.00 %					RW	Num				US
12.005	Threshold Detector 1 Hysteresis	0.00 to 25.00 %				0.00 %	RW	Num				US
12.006	Threshold Detector 1 Output Invert	Off (0) or On (1)				Off (0)	RW	Bit				US
12.007	Threshold Detector 1 Destination						RW	Num	DE		PT	US
12.008	Variable Selector 1 Source 1	0.000 to 59.999				0.000	RW	Num			PT	US
12.009	Variable Selector 1 Source 2						RW	Num			PT	US
12.010	Variable Selector 1 Mode	Input 1 (0), Input 2 (1), Add (2), Subtract (3), Multiply (4), Divide (5), Time Const (6), Ramp (7), Modulus (8), Powers (9), Sectional (10)				Input 1 (0)	RW	Txt				US
12.011	Variable Selector 1 Destination	0.000 to 59.999				0.000	RW	Num	DE		PT	US
12.012	Variable Selector 1 Output	±100.00 %					RO	Num	ND	NC	PT	
12.013	Variable Selector 1 Source 1 Scaling	±4.000				1.000	RW	Num				US
12.014	Variable Selector 1 Source 2 Scaling	±4.000				1.000	RW	Num				US
12.015	Variable Selector 1 Control	0.00 to 100.00				0.00	RW	Num				US
12.016	Variable Selector 1 Enable	Off (0) or On (1)				On (1)	RW	Bit				US
12.023	Threshold Detector 2 Source	0.000 to 59.999				0.000	RW	Num			PT	US
12.024	Threshold Detector 2 Level	0.00 to 100.00 %					RW	Num				US
12.025	Threshold Detector 2 Hysteresis	0.00 to 25.00 %				0.00 %	RW	Num				US
12.026	Threshold Detector 2 Output Invert	Off (0) or On (1)				Off (0)	RW	Bit				US
12.027	Threshold Detector 2 Destination	0.000 to 59.999				0.000	RW	Num	DE		PT	US
12.028	Variable Selector 2 Source 1	0.000 to 59.999				0.000	RW	Num			PT	US
12.029	Variable Selector 2 Source 2	0.000 to 59.999				0.000	RW	Num			PT	US
12.030	Variable Selector 2 Mode	Input 1 (0), Input 2 (1), Add (2), Subtract (3), Multiply (4), Divide (5), Time Const (6), Ramp (7), Modulus (8), Powers (9), Sectional (10)				Input 1 (0)	RW	Txt				US
12.031	Variable Selector 2 Destination	0.000 to 59.999				0.000	RW	Num	DE		PT	US
12.032	Variable Selector 2 Output	±100.00 %					RO	Num	ND	NC	PT	
12.033	Variable Selector 2 Source 1 Scaling	±4.000				1.000	RW	Num				US
12.034	Variable Selector 2 Source 2 Scaling	±4.000				1.000	RW	Num				US
12.035	Variable Selector 2 Control	0.00 to 100.00				0.00	RW	Num				US
12.036	Variable Selector 2 Enable	Off (0) or On (1)				On (1)	RW	Bit				US
12.040	Brake Control: Brake Release	Off (0) or On (1)					RO	Bit	ND	NC	PT	
12.041	Brake Control: Enable	Off (0) or On (1)				Off (0)	RW	Bit				US
12.042	Brake Control: Upper Current Threshold	0 to 200 %		50 %			RW	Num				US
12.043	Brake Control: Lower Current Threshold	0 to 200 %				10 %	RW	Num				US
12.044	OL: Brake Control: Brake Release Frequency	0.0 to 20.0 Hz				1.0 Hz	RW	Num				US
	RFC-A: Brake Control: Brake Release Speed			0 to 200 rpm		10 rpm	RW	Num				US
12.045	OL: Brake Control: Brake Apply Frequency	0.0 to 20.0 Hz				2.0 Hz	RW	Num				US
	RFC-A/S: Brake Control: Brake Apply Speed			0 to 200 rpm		5 rpm	RW	Num				US
12.046	Brake Control: Brake Delay	0.0 to 25.0 s				1.0 s	RW	Num				US
12.047	Brake Control: Post-brake Release Delay	0.0 to 25.0 s				1.0 s	RW	Num				US
12.048	Brake Control: Brake Apply Delay			0.0 to 25.0 s		1.0 s	RW	Num				US
12.049	Brake Control: Enable Position Control During Brake Release			Off (0) or On (1)		Off (0)	RW	Bit				US
12.050	Brake Control: Initial Direction	Ref (0), Forward (1), Reverse (2)				Ref (0)	RW	Txt				US
12.051	Brake Control: Brake Apply Through Zero Threshold	0.0 to 20.0 Hz		0 to 200 rpm		1.0 Hz	RW	Num				US
12.052	Brake Control: Mode			Off (0) or On (1)		On (1)	RW	Bit				US
12.054	External Brake Released Indicator			Off (0) or On (1)		Off (0)	RW	Bit		NC		
12.055	Brake Release Source			Off (0) or On (1)		Off (0)	RW	Bit				

RW	Read / Write	RO	Read only	Num	Number parameter	Bit	Bit parameter	Txt	Text string	Bin	Binary parameter	FI	Filtered
ND	No default value	NC	Not copied	PT	Protected parameter	RA	Rating dependent	US	User save	PS	Power-down save	DE	Destination



## 10.14 Menu 13: Standard motion controller

Figure 10-32 Menu 13 logic diagram

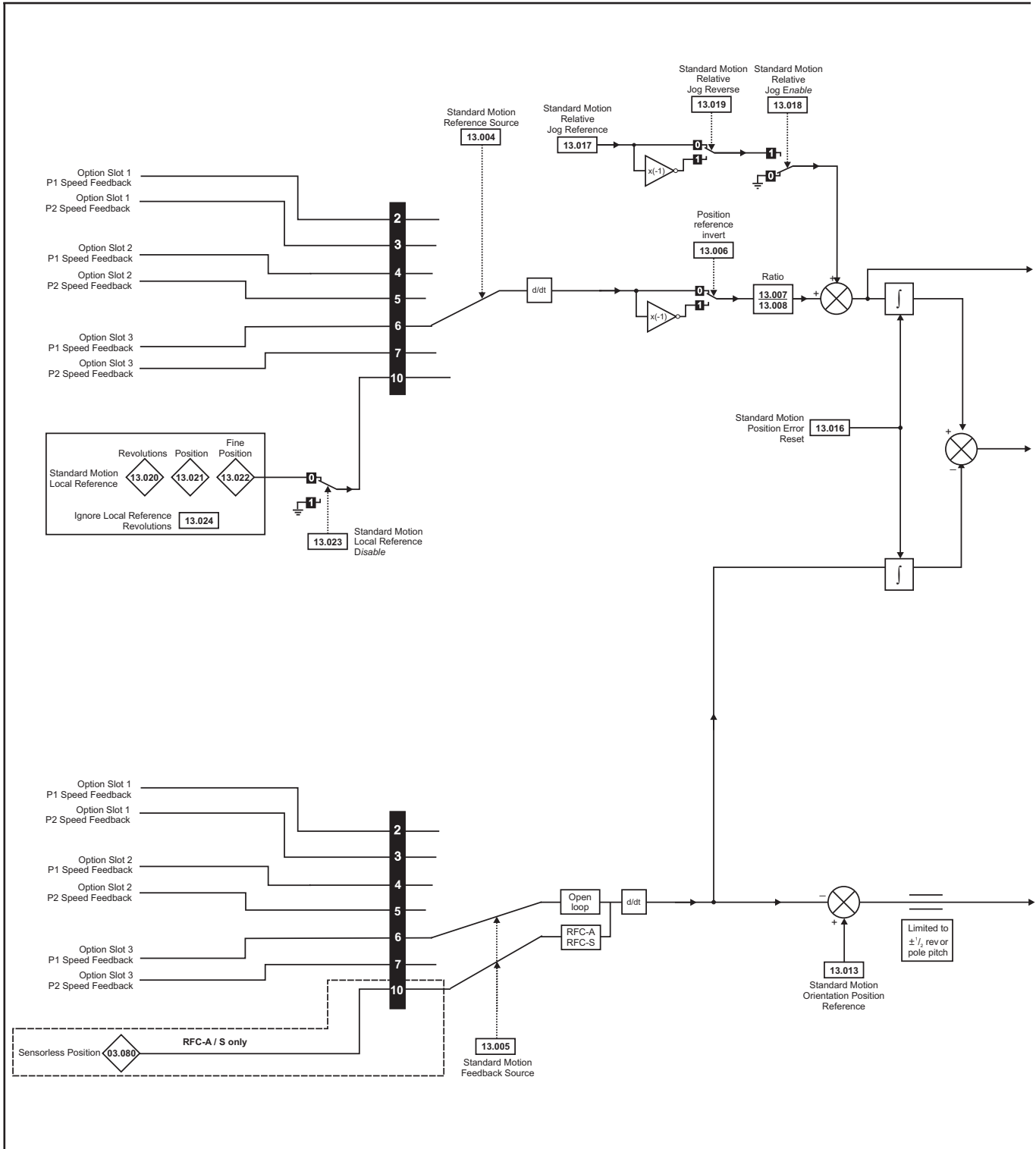

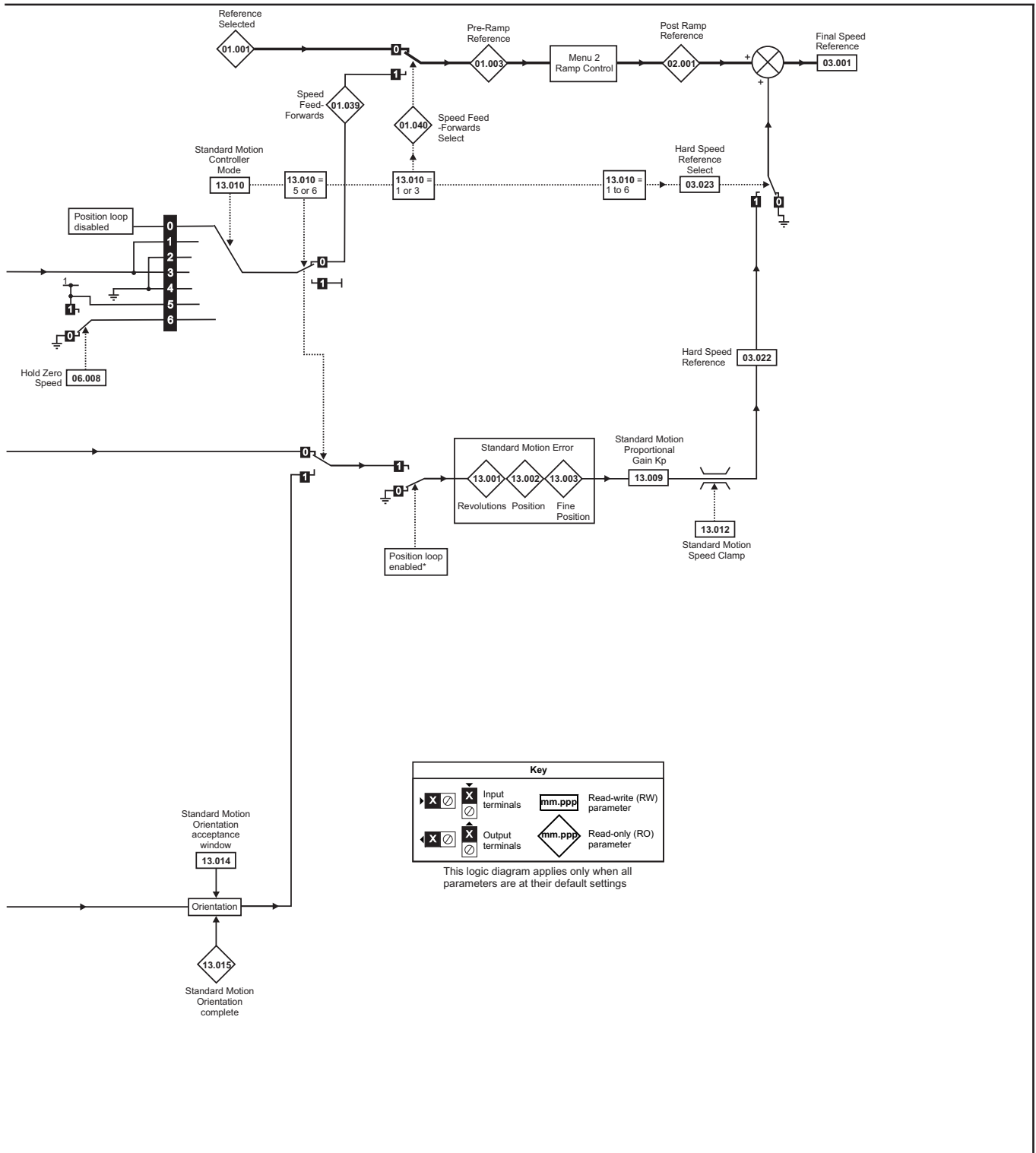

\*The position controller is disabled and the error integrator is also reset under the following conditions:

1. If the drive is disabled (i.e. inhibited, ready or tripped)
2. If the position controller mode (Pr **13.010**) is changed. The position controller is disabled transiently to reset the error integrator.
3. The absolute mode parameter (Pr **13.011**) is changed. The position controller is disabled transiently to reset the error integrator.
4. One of the position sources is invalid.
5. The position feedback initialized parameter (Pr **03.048**) is zero.

Parameter	Range(φ)		Default(⇒)			Type						
	OL	RFC-A / S	OL	RFC-A	RFC-S							
13.001	Standard Motion Revolutions Error	-32768 to 32767 revs					RO	Num	ND	NC	PT	
13.002	Standard Motion Position Error	-32768 to 32767					RO	Num	ND	NC	PT	
13.003	Standard Motion Fine Position Error	-32768 to 32767					RO	Num	ND	NC	PT	
13.004	Standard Motion Reference Source	P1 Slot 1 (2), P2 Slot 1 (3), P1 Slot 2 (4), P2 Slot 2 (5), P1 Slot 3 (6), P2 Slot 3 (7), Local (10)		P1 Slot 3 (6)			RW	Txt				US
13.005	Standard Motion Feedback Source	P1 Slot 1 (2), P2 Slot 1 (3), P1 Slot 2 (4), P2 Slot 2 (5), P1 Slot 3 (6), P2 Slot 3 (7)	P1 Slot 1 (2), P2 Slot 1 (3), P1 Slot 2 (4), P2 Slot 2 (5), P1 Slot 3 (6), P2 Slot 3 (7), Sensorless (10)	P1 Slot 3 (6)	Sensorless (10)		RW	Txt				US
13.006	Standard Motion Reference Invert	Off (0) or On (1)		Off (0)			RW	Bit				
13.007	Standard Motion Ratio Numerator	0.000 to 10.000		1.000			RW	Num				US
13.008	Standard Motion Ratio Denominator	0.000 to 4.000		1.000			RW	Num				US
13.009	Standard Motion Proportional Gain Kp	0.00 to 100.00		25.00			RW	Num				US
13.010	Standard Motion Controller Mode	Disabled (0), Rigid Spd FF (1), Rigid (2), Non-rigid Spd FF (3), Non-rigid (4)	Disabled (0), Rigid Spd FF (1), Rigid (2), Non-rigid Spd FF (3), Non-rigid (4), Orientate Stop (5), Orientate (6)	Disabled (0)			RW	Txt				US
13.011	Standard Motion Absolute Mode Enable	Off (0) or On (1)		Off (0)			RW	Bit				US
13.012	Standard Motion Speed Clamp	0 to 250 rpm		150 rpm			RW	Num				US
13.013	Standard Motion Orientation Position Reference	0 to 65535		0			RW	Num				US
13.014	Standard Motion Orientation Acceptance Window	0 to 4096		256			RW	Num				US
13.015	Standard Motion Orientation Complete	Off (0) or On (1)					RO	Bit	ND	NC	PT	
13.016	Standard Motion Position Error Reset	Off (0) or On (1)		Off (0)			RW	Bit		NC		
13.017	Standard Motion Relative Jog Reference	0.0 to 4000.0 rpm		0.0 rpm			RW	Num				US
13.018	Standard Motion Relative Jog Enable	Off (0) or On (1)		Off (0)			RW	Bit		NC		
13.019	Standard Motion Relative Jog Reverse	Off (0) or On (1)		Off (0)			RW	Bit		NC		
13.020	Standard Motion Local Reference Revolutions	0 to 65535 revs		0 revs			RW	Num		NC		
13.021	Standard Motion Local Reference Position	0 to 65535		0			RW	Num		NC		
13.022	Standard Motion Local Reference Fine Position	0 to 65535		0			RW	Num		NC		
13.023	Standard Motion Local Reference Disable	Off (0) or On (1)		Off (0)			RW	Bit		NC		
13.024	Standard Motion Ignore Local Reference Revolutions	Off (0) or On (1)		Off (0)			RW	Bit				US
13.026	Standard Motion Sample Rate	Not Active (0), 4ms (1)		Not Active (0)			RO	Txt				US

RW	Read / Write	RO	Read only	Num	Number parameter	Bit	Bit parameter	Txt	Text string	Bin	Binary parameter	FI	Filtered
ND	No default value	NC	Not copied	PT	Protected parameter	RA	Rating dependent	US	User save	PS	Power-down save	DE	Destination



## 10.15 Menu 14: User PID controller

Figure 10-33 Menu 14 Logic diagram

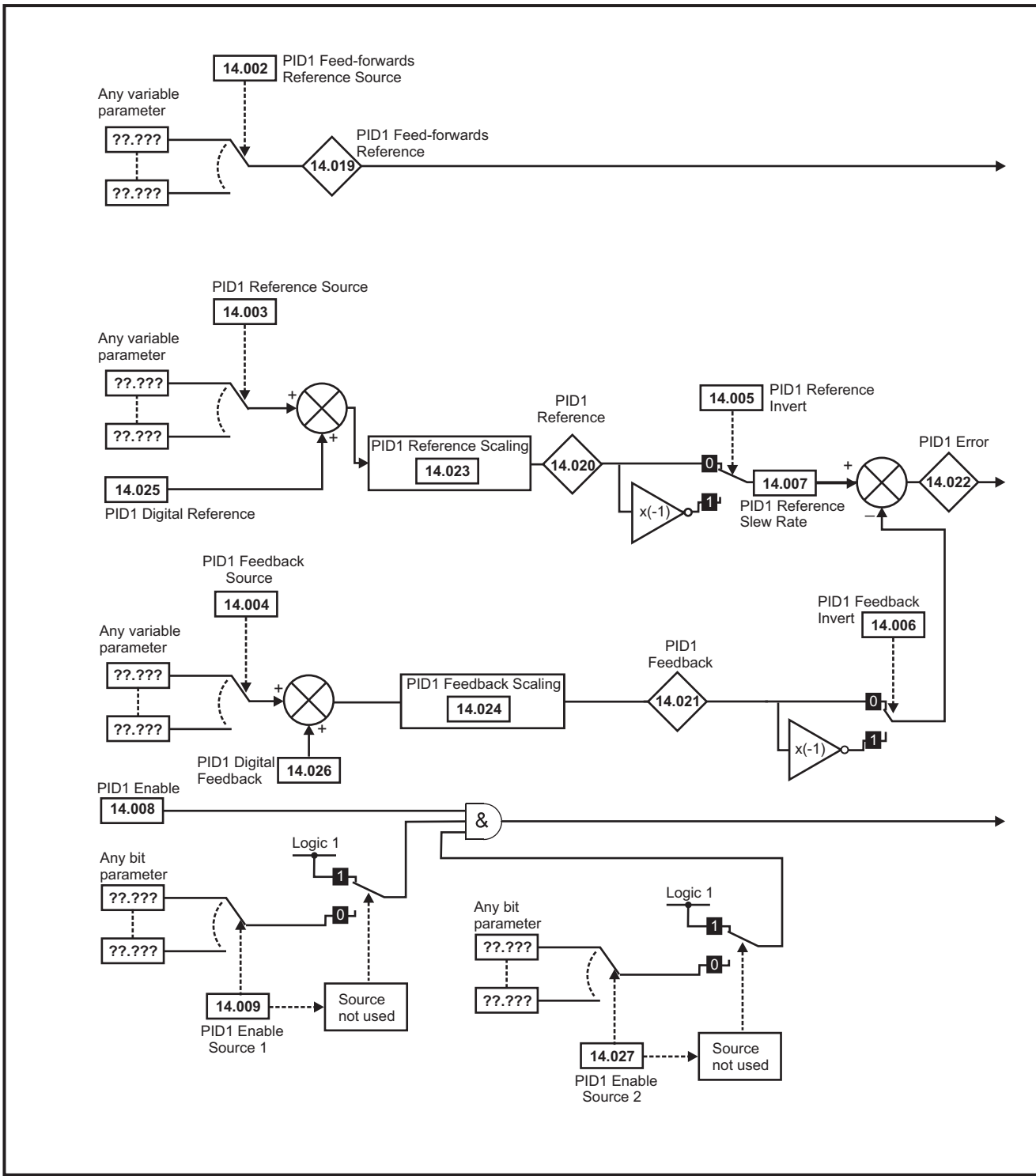

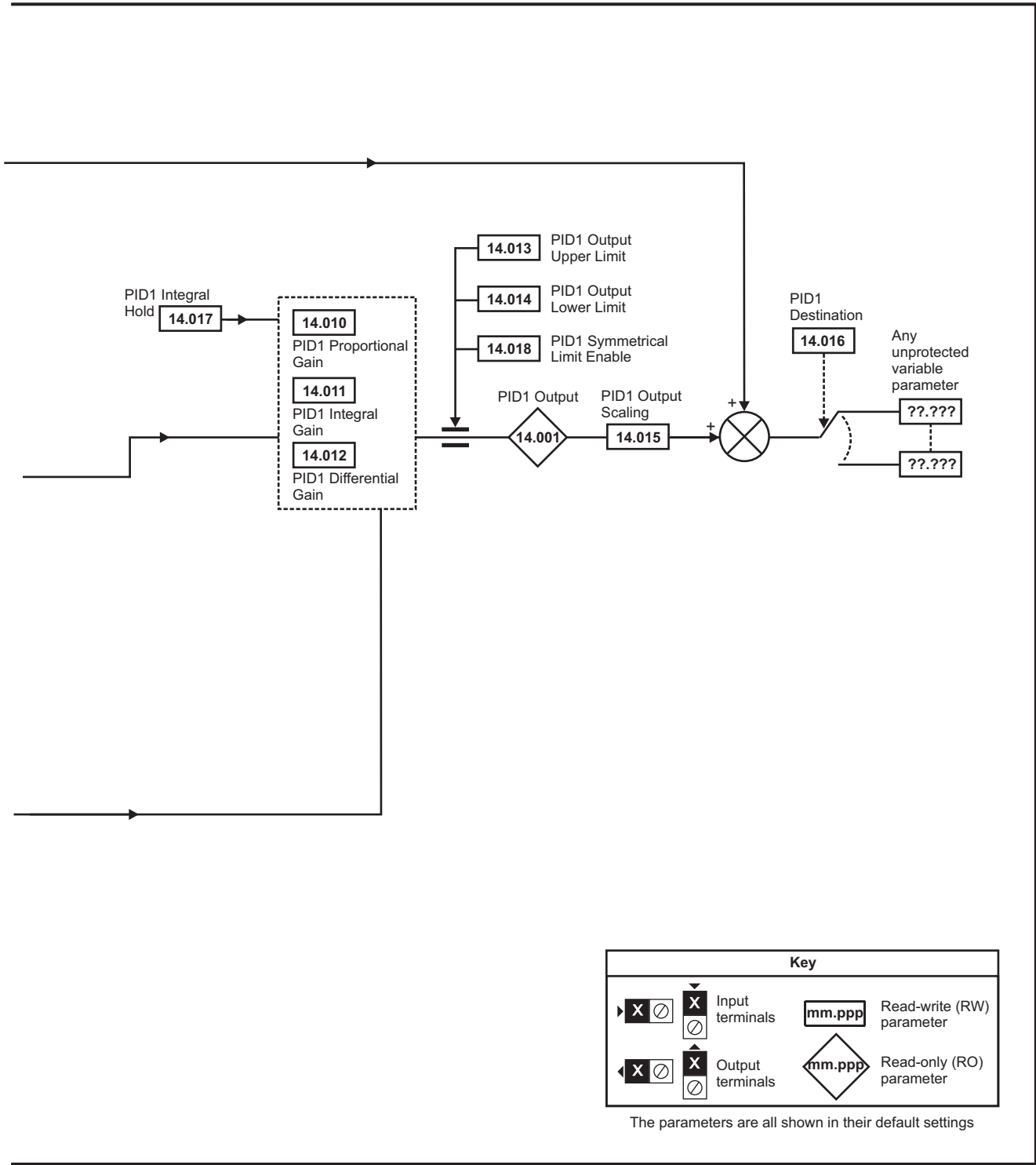

Parameter	Range(⊕)		Default(⇔)			Type						
	OL	RFC-A / S	OL	RFC-A	RFC-S							
14.001	PID1 Output	±100.00 %				RO	Num	ND	NC	PT		
14.002	PID1 Feed-forwards Reference Source	0.000 to 59.999		0.000		RW	Num			PT	US	
14.003	PID1 Reference Source	0.000 to 59.999		0.000		RW	Num			PT	US	
14.004	PID1 Feedback Source	0.000 to 59.999		0.000		RW	Num			PT	US	
14.005	PID1 Reference Invert	Off (0) or On (1)		Off (0)		RW	Bit					
14.006	PID1 Feedback Invert	Off (0) or On (1)		Off (0)		RW	Bit					
14.007	PID1 Reference Slew Rate	0.0 to 3200.0 s		0.0 s		RW	Num					US
14.008	PID1 Enable	Off (0) or On (1)		Off (0)		RW	Bit					US
14.009	PID1 Enable Source 1	0.000 to 59.999		0.000		RW	Num			PT	US	
14.010	PID1 Proportional Gain	0.000 to 4.000		1.000		RW	Num					US
14.011	PID1 Integral Gain	0.000 to 4.000		0.500		RW	Num					US
14.012	PID1 Differential Gain	0.000 to 4.000		0.000		RW	Num					US
14.013	PID1 Output Upper Limit	0.00 to 100.00 %		100.00 %		RW	Num					US
14.014	PID1 Output Lower Limit	±100.00 %		-100.00 %		RW	Num					US
14.015	PID1 Output Scaling	0.000 to 4.000		1.000		RW	Num					US
14.016	PID1 Destination	0.000 to 59.999		0.000		RW	Num	DE		PT	US	
14.017	PID1 Integral Hold	Off (0) or On (1)		Off (0)		RW	Bit					
14.018	PID1 Symmetrical Limit Enable	Off (0) or On (1)		Off (0)		RW	Bit					US
14.019	PID1 Feed-forwards Reference	±100.00 %				RO	Num	ND	NC	PT		
14.020	PID1 Reference	±100.00 %				RO	Num	ND	NC	PT		
14.021	PID1 Feedback	±100.00 %				RO	Num	ND	NC	PT		
14.022	PID1 Error	±100.00 %				RO	Num	ND	NC	PT		
14.023	PID1 Reference Scaling	0.000 to 4.000		1.000		RW	Num					US
14.024	PID1 Feedback Scaling	0.000 to 4.000		1.000		RW	Num					US
14.025	PID1 Digital Reference	±100.00 %		0.00 %		RW	Num					US
14.026	PID1 Digital Feedback	±100.00 %		0.00 %		RW	Num					US
14.027	PID1 Enable Source 2	0.000 to 59.999		0.000		RW	Num			PT	US	

RW	Read / Write	RO	Read only	Num	Number parameter	Bit	Bit parameter	Txt	Text string	Bin	Binary parameter	FI	Filtered
ND	No default value	NC	Not copied	PT	Protected parameter	RA	Rating dependent	US	User save	PS	Power-down save	DE	Destination

## 10.16 Menus 15, 16 and 17: Option module set-up

Figure 10-34 Location of option module slots and their corresponding menu numbers

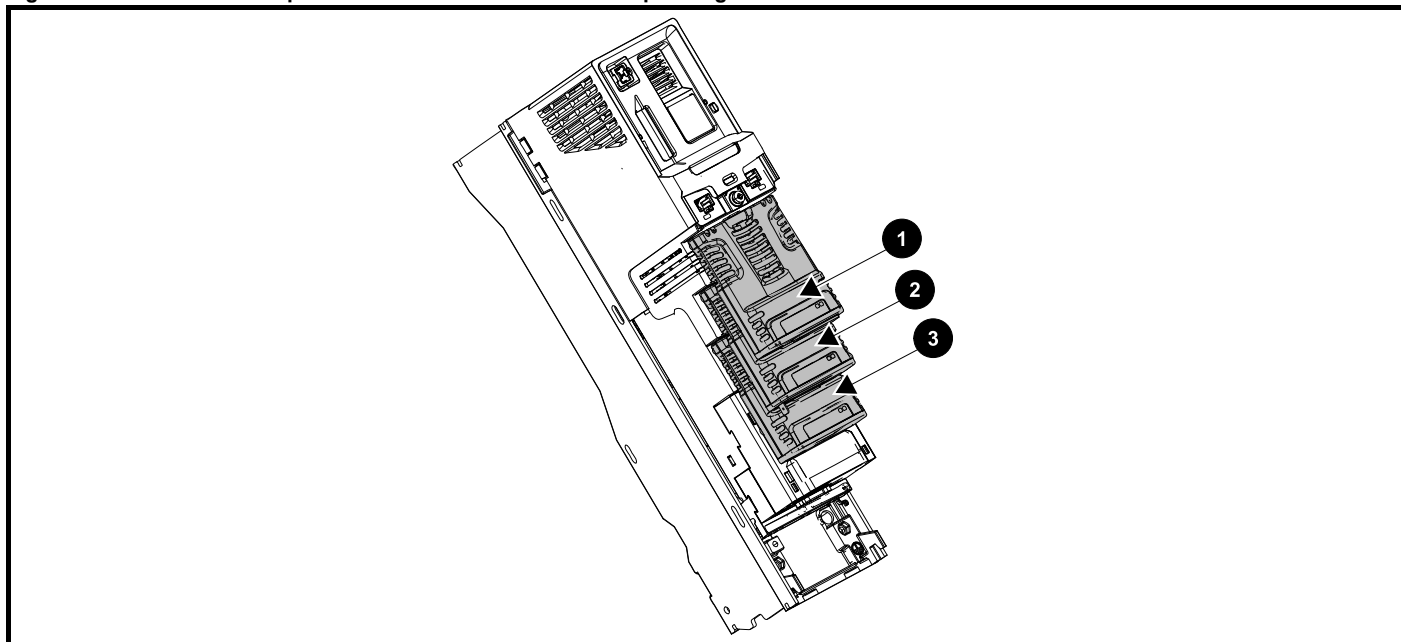

1. Solutions Module Slot 1 - Menu 15
2. Solutions Module Slot 2 - Menu 16
3. Solutions Module Slot 3 - Menu 17

### 10.16.1 Parameters common to all categories

Parameter		Range(↕)	Default(⇒)	Type					
mm.001	Module ID	0 to 65535		RO	Num	ND	NC	PT	
mm.002	Software Version	00.00.00.00 to 99.99.99.99		RO	Ver	ND	NC	PT	
mm.003	Hardware Version	0.00 to 99.99		RO	Num	ND	NC	PT	
mm.004	Serial Number LS	0 to 99999999		RO	Num	ND	NC	PT	
mm.005	Serial Number MS			RO	Num	ND	NC	PT	
mm.006	Module Status	-2 to 3		RO	Num	ND	NC	PT	
mm.007	Module Reset	Off (0) to On (1)		Off (0)	RW	Bit		NC	

The option module ID indicates the type of module that is installed in the corresponding slot. See the relevant option module user guide for more information regarding the module.

Option module ID	Module	Category
0	No module installed	
209	SI-I/O	Automation (I/O Expansion)
443	SI-PROFIBUS	Fieldbus
447	SI-DeviceNet	
448	SI-CANopen	
433	SI-Ethernet	
432	SI-PROFINET RT	
434	SI-PROFINET V2	
431	SI-EtherCAT	Feedback
105	SI-Encoder	
106	SI-Universal Encoder	
0*	SI-Safety	Safety

\* There is no communication between the SI-Safety option module and the host drive via the option module connector, this is why the SI-Safety module ID is displayed as zero.

## 10.17 Menu 18: Application menu 1

Parameter	Range(⇅)		Default(⇒)			Type					
	OL	RFC-A / S	OL	RFC-A	RFC-S						
18.001 Application Menu 1 Power-down Save Integer	-32768 to 32767		0			RW	Num				PS
18.002 to 18.010 Application Menu 1 Read-only Integer	-32768 to 32767					RO	Num	ND	NC		US
18.011 to 18.030 Application Menu 1 Read-write Integer	-32768 to 32767		0			RW	Num				US
18.031 to 18.050 Application Menu 1 Read-write bit	Off (0) or On (1)		Off (0)			RW	Bit				US
18.051 to 18.054 Application Menu 1 Power-down Save long Integer	-2147483648 to 2147483647		0			RW	Num				PS

RW	Read / Write	RO	Read only	Num	Number parameter	Bit	Bit parameter	Txt	Text string	Bin	Binary parameter	FI	Filtered
ND	No default value	NC	Not copied	PT	Protected parameter	RA	Rating dependent	US	User save	PS	Power-down save	DE	Destination

## 10.18 Menu 19: Application menu 2

Parameter	Range(⇅)		Default(⇒)			Type					
	OL	RFC-A / S	OL	RFC-A	RFC-S						
19.001 Application Menu 2 Power-down Save Integer	-32768 to 32767		0			RW	Num				PS
19.002 to 19.010 Application Menu 2 Read-only Integer	-32768 to 32767					RO	Num	ND	NC		US
19.011 to 19.030 Application Menu 2 Read-write Integer	-32768 to 32767		0			RW	Num				US
19.031 to 19.050 Application Menu 2 Read-write bit	Off (0) or On (1)		Off (0)			RW	Bit				US
19.051 to 19.054 Application Menu 2 Power-down Save long Integer	-2147483648 to 2147483647		0			RW	Num				PS

RW	Read / Write	RO	Read only	Num	Number parameter	Bit	Bit parameter	Txt	Text string	Bin	Binary parameter	FI	Filtered
ND	No default value	NC	Not copied	PT	Protected parameter	RA	Rating dependent	US	User save	PS	Power-down save	DE	Destination

## 10.19 Menu 20: Application menu 3

Parameter	Range(⇅)		Default(⇒)			Type					
	OL	RFC-A / S	OL	RFC-A	RFC-S						
20.001 to 20.020 Application Menu 3 Read-write Integer	-32768 to 32767		0			RW	Num				
20.021 to 20.040 Application Menu 3 Read-write Long Integer	-2147483648 to 2147483647		0			RW	Num				

RW	Read / Write	RO	Read only	Num	Number parameter	Bit	Bit parameter	Txt	Text string	Bin	Binary parameter	FI	Filtered
ND	No default value	NC	Not copied	PT	Protected parameter	RA	Rating dependent	US	User save	PS	Power-down save	DE	Destination

## 10.20 Menu 21: Second motor parameters

Parameter	Range(⇅)			Default(⇒)			Type						
	OL	RFC-A	RFC-S	OL	RFC-A	RFC-S							
21.001	M2 Maximum Reference Clamp	0.0 to VM_POSITIVE_REF_CLAMP2			50 Hz: 50.0 60 Hz: 60.0	50 Hz: 1500.0 60 Hz: 1800.0		RW	Num				US
21.002	M2 Minimum Reference Clamp	VM_NEGATIVE_REF_CLAMP2 to 0.0			0.0			RW	Num				US
21.003	M2 Reference Selector	A1 A2 (0), A1 Preset (1), A2 Preset (2), Preset (3), Keypad (4), Precision (5), Keypad Ref (6)			A1 A2 (0)			RW	Txt				US
21.004	M2 Acceleration Rate 1	0.0 to VM_ACCEL_RATE s/100 Hz	0.000 to VM_ACCEL_RATE s/1000 rpm		5.0	2.000		RW	Num				US
21.005	M2 Deceleration Rate 1	0.0 to VM_ACCEL_RATE s/100 Hz	0.000 to VM_ACCEL_RATE s/1000 rpm		10.0	2.000		RW	Num				US
21.006	M2 Rated Frequency	0.0 to 550.0 Hz	0.0 to 550.0 Hz		50 Hz: 50.0 60 Hz: 60.0		RW	Num					US
21.007	M2 Rated Current	0.000 to VM_RATED_CURRENT			Maximum Heavy Duty Rating (11.032)			RW	Num		RA		US
21.008	M2 Rated Speed	0 to 33000 rpm	0 to 33000.0 rpm		50 Hz: 1500 rpm 60 Hz: 1800 rpm	50 Hz: 1450.00 rpm 60 Hz: 1750.00 rpm	3000.0 rpm	RW	Num				US
21.009	M2 Rated Voltage	0 to VM_AC_VOLTAGE_SET			200 V drive: 230 V Eur - 400 V drive: 400 V USA - 400 V drive: 460 V 575 V drive: 575 V 690 V drive: 690 V			RW	Num		RA		US
21.010	M2 Rated Power Factor	0.000 to 1.000			0.850		RW	Num		RA			US
21.011	M2 Number Of Motor Poles	Automatic (0) to 480 Poles (240)			Automatic (0)		8 Poles (4)	RW	Txt				US
21.012	M2 Stator Resistance	0.000000 to 1000.000000 Ω			0.000000 Ω			RW	Num		RA		US
21.014	M2 Transient Inductance / Ld	0.000 to 500.000 mH			0.000 mH			RW	Num		RA		US
21.015	Motor 2 Active	Off (0) or On (1)						RO	Bit	ND	NC	PT	
21.016	M2 Motor Thermal Time Constant 1	1.0 to 3000.0 s			89.0 s			RW	Num				US
21.017	M2 Speed Controller Proportional Gain Kp1		0.0000 to 200.0000 s/rad			0.0300 s/rad	0.0100 s/rad	RW	Num				US
21.018	M2 Speed Controller Integral Gain Ki1		0.00 to 655.35 s <sup>2</sup> /rad			0.10 s <sup>2</sup> /rad	0.05 s <sup>2</sup> /rad	RW	Num				US
21.019	M2 Speed Controller Differential Feedback Gain Kd1		0.00000 to 0.65535 1/rad			0.00000 1/rad		RW	Num				US
21.021	M2 Motor Control Feedback Select		P1 Slot 1 (2), P2 Slot 1 (3), P1 Slot 2 (4), P2 Slot 2 (5), P1 Slot 3 (6), P2 Slot 3 (7)			P1 Slot 3 (6)		RW	Txt				US
21.022	M2 Current Controller Kp Gain	0 to 30000			20	150		RW	Num				US
21.023	M2 Current Controller Ki Gain	0 to 30000			40	2000		RW	Num				US
21.024	M2 Stator Inductance	0.00 to 5000.00 mH			0.00 mH		RW	Num		RA			US
21.025	M2 Saturation Breakpoint 1		0.0 to		50.0 %		RW	Num					US
21.026	M2 Saturation Breakpoint 3		100.0 %		75.0 %		RW	Num					US
21.027	M2 Motoring Current Limit	0.0 to VM_MOTOR2_CURRENT_LIMIT			165.0 % *		175.0 % **	RW	Num		RA		US
21.028	M2 Regenerating Current Limit	0.0 to VM_MOTOR2_CURRENT_LIMIT			165.0 % *		175.0 % **	RW	Num		RA		US
21.029	M2 Symmetrical Current Limit	0.0 to VM_MOTOR2_CURRENT_LIMIT			165.0 % *		175.0 % **	RW	Num		RA		US
21.030	M2 Volts Per 1000 rpm		0 to 10000 V		98 V		RW	Num					US
21.032	M2 Current Reference Filter Time Constant 1		0.0 to 25.0 ms			1.0 ms		RW	Num				US
21.033	M2 Low Speed Thermal Protection Mode	0 to 1			0			RW	Num				US
21.039	M2 Motor Thermal Time Constant 2	1.0 to 3000.0 s			89.0 s			RW	Num				US
21.040	M2 Motor Thermal Time Constant 2 Scaling	0 to 100 %			0 %			RW	Num				US
21.041	M2 Saturation Breakpoint 2		0.0 to 100.0 %		0.0 %		RW	Num					US
21.042	M2 Saturation Breakpoint 4		0.0 to 100.0 %		0.0 %		RW	Num					US
21.043	RFC-A> M2 Torque Per Amp		0.00 to 500.00					RO	Num	ND	NC	PT	
	RFC-S> M2 Torque Per Amp			0.00 to 500.00 Nm/A		1.60 Nm/A		RW	Num				US
21.044	M2 No Load Core Loss	0.000 to 99999.999			0.000			RW	Num				US
21.045	M2 Rated Core Loss	0.000 to 99999.999			0.000			RW	Num				US
21.046	M2 Inverted Motor Saturation Characteristic			Off (0) or On (1)		Off (0)		RW	Bit				US
	M2 Magnetising Current Limit		0.0 to 100.0 %			100.0 %		RW	Num				US
21.047	M2 Low Speed Sensorless Mode Current Limit			0.0 to 1000.0 %		20.0 %		RW	Num		RA		US
21.048	M2 No-load Lq			0.000 to 500.000 mH		0.000 mH		RW	Num		RA		US
21.051	M2 Iq Test Current For Inductance Measurement		0 to 200 %			100 %		RW	Num				US

Parameter		Range(ϕ)			Default(⇒)			Type					
		OL	RFC-A	RFC-S	OL	RFC-A	RFC-S						
21.053	M2 Phase Offset At Iq Test Current			±90.0 °			0.0 °	RW	Num		RA		US
21.054	M2 Lq At Defined Iq Test Current			0.000 to 500.000 mH			0.000 mH	RW	Num		RA		US
21.058	M2 Id Test Current For Inductance Measurement			-100 to 0 %			-50 %	RW	Num				US
21.060	M2 Lq at the defined Id test current			0.000 to 500.000 mH			0.000 mH	RW	Num		RA		US

\* For size 9 and above the default is 141.9 %

\*\*For size 9 and above the default is 150.0 %

RW	Read / Write	RO	Read only	Num	Number parameter	Bit	Bit parameter	Txt	Text string	Bin	Binary parameter	FI	Filtered
ND	No default value	NC	Not copied	PT	Protected parameter	RA	Rating dependent	US	User save	PS	Power-down save	DE	Destination

## 10.21 Menu 22: Additional Menu 0 set-up

Parameter	Range(↕)			Default(⇒)			Type					
	OL	RFC-A	RFC-S	OL	RFC-A	RFC-S						
22.001	Parameter 00.001 Set-up	00.000 to 59.999			01.007		RW	Num			PT	US
22.002	Parameter 00.002 Set-up				01.006		RW	Num			PT	US
22.003	Parameter 00.003 Set-up				02.011		RW	Num			PT	US
22.004	Parameter 00.004 Set-up				02.021		RW	Num			PT	US
22.005	Parameter 00.005 Set-up				01.014		RW	Num			PT	US
22.006	Parameter 00.006 Set-up				04.007		RW	Num			PT	US
22.007	Parameter 00.007 Set-up				05.014	03.010	RW	Num			PT	US
22.008	Parameter 00.008 Set-up				05.015	03.011	RW	Num			PT	US
22.009	Parameter 00.009 Set-up				05.013	03.012	RW	Num			PT	US
22.010	Parameter 00.010 Set-up				05.004	03.002	RW	Num			PT	US
22.011	Parameter 00.011 Set-up				05.001	03.029	RW	Num			PT	US
22.012	Parameter 00.012 Set-up				04.001		RW	Num			PT	US
22.013	Parameter 00.013 Set-up				04.002		RW	Num			PT	US
22.014	Parameter 00.014 Set-up				04.011		RW	Num			PT	US
22.015	Parameter 00.015 Set-up				02.004		RW	Num			PT	US
22.016	Parameter 00.016 Set-up				00.000	02.002	RW	Num			PT	US
22.017	Parameter 00.017 Set-up				08.026	04.012	RW	Num			PT	US
22.018	Parameter 00.018 Set-up				00.000		RW	Num			PT	US
22.019	Parameter 00.019 Set-up				07.011		RW	Num			PT	US
22.020	Parameter 00.020 Set-up				07.014		RW	Num			PT	US
22.021	Parameter 00.021 Set-up				07.015		RW	Num			PT	US
22.022	Parameter 00.022 Set-up				01.010		RW	Num			PT	US
22.023	Parameter 00.023 Set-up				01.005		RW	Num			PT	US
22.024	Parameter 00.024 Set-up				01.021		RW	Num			PT	US
22.025	Parameter 00.025 Set-up				01.022		RW	Num			PT	US
22.026	Parameter 00.026 Set-up				01.023	03.008	RW	Num			PT	US
22.027	Parameter 00.027 Set-up				01.024	03.034	RW	Num			PT	US
22.028	Parameter 00.028 Set-up				06.013		RW	Num			PT	US
22.029	Parameter 00.029 Set-up				11.036		RW	Num			PT	US
22.030	Parameter 00.030 Set-up				11.042		RW	Num			PT	US
22.031	Parameter 00.031 Set-up				11.033		RW	Num			PT	US
22.032	Parameter 00.032 Set-up				11.032		RW	Num			PT	US
22.033	Parameter 00.033 Set-up				06.009	05.016	00.000	RW	Num		PT	US
22.034	Parameter 00.034 Set-up				11.030		RW	Num			PT	US
22.035	Parameter 00.035 Set-up				11.024		RW	Num			PT	US
22.036	Parameter 00.036 Set-up				11.025		RW	Num			PT	US
22.037	Parameter 00.037 Set-up				11.023		RW	Num			PT	US
22.038	Parameter 00.038 Set-up				04.013		RW	Num			PT	US
22.039	Parameter 00.039 Set-up				04.014		RW	Num			PT	US
22.040	Parameter 00.040 Set-up				05.012		RW	Num			PT	US
22.041	Parameter 00.041 Set-up				05.018		RW	Num			PT	US
22.042	Parameter 00.042 Set-up				05.011		RW	Num			PT	US
22.043	Parameter 00.043 Set-up				05.010	00.000	RW	Num			PT	US
22.044	Parameter 00.044 Set-up				05.009		RW	Num			PT	US
22.045	Parameter 00.045 Set-up				05.008		RW	Num			PT	US
22.046	Parameter 00.046 Set-up				05.007		RW	Num			PT	US
22.047	Parameter 00.047 Set-up				05.006	05.033	RW	Num			PT	US
22.048	Parameter 00.048 Set-up				11.031		RW	Num			PT	US
22.049	Parameter 00.049 Set-up				11.044		RW	Num			PT	US
22.050	Parameter 00.050 Set-up				11.029		RW	Num			PT	US
22.051	Parameter 00.051 Set-up				10.037		RW	Num			PT	US
22.052	Parameter 00.052 Set-up				11.020		RW	Num			PT	US
22.053	Parameter 00.053 Set-up				04.015		RW	Num			PT	US
22.054	Parameter 00.054 Set-up				00.000	05.064	RW	Num			PT	US
22.055	Parameter 00.055 Set-up				00.000	05.071	RW	Num			PT	US
22.056	Parameter 00.056 Set-up				00.000	05.072	RW	Num			PT	US
22.057	Parameter 00.057 Set-up				00.000	05.075	RW	Num			PT	US

Parameter		Range(⇅)			Default(⇔)			Type								
		OL	RFC-A	RFC-S	OL	RFC-A	RFC-S									
22.058	Parameter 00.058 Set-up	00.000 to 59.999			00.000		05.077	RW	Num			PT	US			
22.059	Parameter 00.059 Set-up				00.000		05.078	RW	Num			PT	US			
22.060	Parameter 00.060 Set-up				00.000		05.082	RW	Num			PT	US			
22.061	Parameter 00.061 Set-up				00.000		05.084	RW	Num			PT	US			
22.062	Parameter 00.062 Set-up				00.000						RW	Num			PT	US
22.063	Parameter 00.063 Set-up										RW	Num			PT	US
22.064	Parameter 00.064 Set-up										RW	Num			PT	US
22.065	Parameter 00.065 Set-up										RW	Num			PT	US
22.066	Parameter 00.066 Set-up										RW	Num			PT	US
22.067	Parameter 00.067 Set-up										RW	Num			PT	US
22.068	Parameter 00.068 Set-up										RW	Num			PT	US
22.069	Parameter 00.069 Set-up										RW	Num			PT	US
22.070	Parameter 00.070 Set-up										RW	Num			PT	US
22.071	Parameter 00.071 Set-up										00.000				PT	US
22.072	Parameter 00.072 Set-up								PT	US						
22.073	Parameter 00.073 Set-up								PT	US						
22.074	Parameter 00.074 Set-up								PT	US						
22.075	Parameter 00.075 Set-up								PT	US						
22.076	Parameter 00.076 Set-up								PT	US						
22.077	Parameter 00.077 Set-up								PT	US						
22.078	Parameter 00.078 Set-up					PT	US									
22.079	Parameter 00.079 Set-up					PT	US									
22.080	Parameter 00.080 Set-up					PT	US									

RW	Read / Write	RO	Read only	Num	Number parameter	Bit	Bit parameter	Txt	Text string	Bin	Binary parameter	FI	Filtered
ND	No default value	NC	Not copied	PT	Protected parameter	RA	Rating dependent	US	User save	PS	Power-down save	DE	Destination

# 11 Diagnostics

The keypad display on the drive gives various information about the status of the drive. The keypad display provides information on the following categories:

- Trip indications
- Alarm indications
- Status indications



Users must not attempt to repair a drive if it is faulty, nor carry out fault diagnosis other than through the use of the diagnostic features described in this chapter. If a drive is faulty, it must be returned to an authorized Nidec Industrial Automation distributor for repair.

## 11.1 Status modes (Keypad and LED status)

Figure 11-1 Keypad status modes

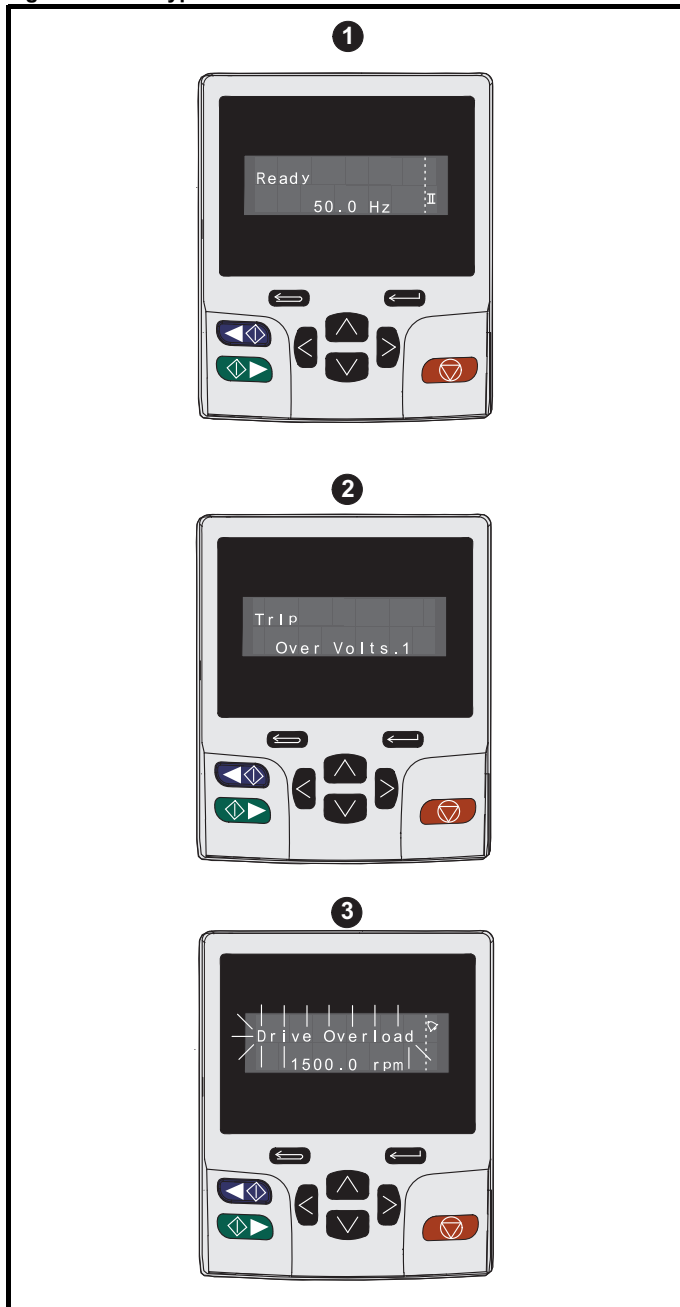

1. Drive healthy status
2. Trip status
3. Alarm status

Figure 11-2 Location of the status LED

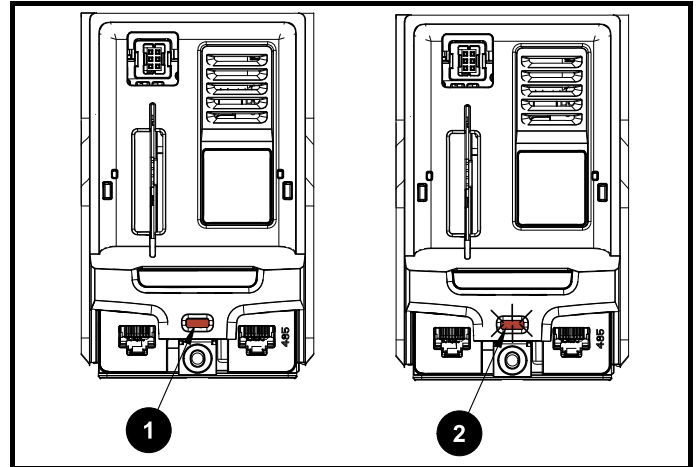

1. Non flashing: Normal status
2. Flashing: Trip status

## 11.2 Trip indications

The output of the drive is disabled under any trip condition so that the drive stops controlling the motor. If the motor is running when the trip occurs it will coast to a stop.

During a trip condition, where a KI-Keypad is being used, the upper row of the display indicates that a trip has occurred and the lower row of the keypad display will display the trip string. Some trips have a sub-trip number to provide additional information about the trip. If a trip has a sub-trip number, the sub-trip number is flashed alternately with the trip string unless there is space on the second row for both the trip string and the sub-trip number in which case both the trip string and sub-trip information is displayed separated by a decimal place.

The back-light of the KI-Keypad display will also flash during a trip condition. If a display is not being used, the drive LED Status indicator will flash with 0.5 s duty cycle if the drive has tripped. Refer to Figure 11-2.

Trips are listed alphabetically in Table 11-3 based on the trip indication shown on the drive display. Alternatively, the drive status can be read in Pr **10.001** 'Drive healthy' using communication protocols. The most recent trip can be read in Pr **10.020** providing a trip number. It must be noted that the hardware trips (HF01 to HF20) do not have trip numbers. The trip number must be checked in Table 11-4 to identify the specific trip.

### Example

1. Trip code 2 is read from Pr **10.020** via serial communications.
2. Checking Table 11-3 shows Trip 2 is an Over Volts trip.

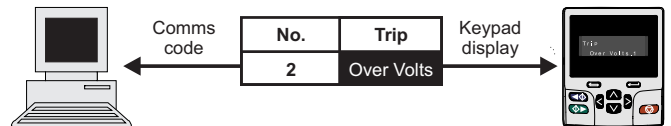

3. Look up Over Volts in Table 11-3.
4. Perform checks detailed under *Diagnosis*.

### 11.3 Identifying a trip / trip source

Some trips only contain a trip string whereas some other trips have a trip string along with a sub-trip number which provides the user with additional information about the trip.

A trip can be generated from a control system or from a power system. The sub-trip number associated with the trips listed in Table 11-1 is in the form xxyz and used to identify the source of the trip.

**Table 11-1 Trips associated with xxyz sub-trip number**

Over Volts	Oht dc bus
OI ac	Phase Loss
OI Brake	Power Comms
PSU	OI Snubber
Oht Inverter	Temp Feedback
Oht Power	Power Data
Oht Control	

The digits xx are 00 for a trip generated by the control system. For a single drive (not part of a multi-power module drive), if the trip is related to the power system then xx will have a value of 01, when displayed the leading zeros are suppressed.

The y digit is used to identify the location of a trip which is generated by a rectifier module connected to a power module (if xx is non zero). For a control system trip (xx is zero), the y digit, where relevant is defined for each trip. If not relevant, the y digit will have a value of zero.

The zz digits give the reason for the trip and are defined in each trip description.

**Figure 11-3 Key to sub-trip number**

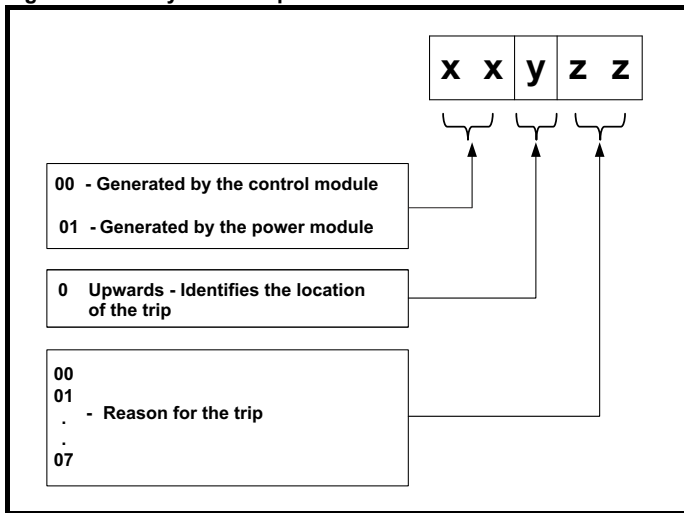

For example, if the drive has tripped and the lower line of the display shows 'Oht Control.2', with the help of Table 11-2 below the trip can be interpreted as; an over temperature has been detected; the trip was generated by fault in the control module, the control board thermistor 2 over temperature.

**Table 11-2 Sub-trip identification**

Source	xx	y	zz	Description
Control system	00	0	01	Control board thermistor 1 over temperature
Control system	00	0	02	Control board thermistor 2 over temperature
Control system	00	0	03	Control board thermistor 3 over temperature

## 11.4 Trips, Sub-trip numbers

Table 11-3 Trip indications

Trip	Diagnosis								
<b>An Input 1 Loss</b>	<b>Analog input 1 current loss</b>								
28	<p><i>An Input 1 Loss</i> trip indicates that a current loss was detected in current mode on Analog input 1 (Terminal 5, 6). In 4-20 mA and 20-4 mA modes loss of input is detected if the current falls below 3 mA.</p> <p><b>Recommended actions:</b></p> <ul style="list-style-type: none"> <li>• Check control wiring is correct</li> <li>• Check control wiring is undamaged</li> <li>• Check the <i>Analog Input 1 Mode</i> (07.007)</li> <li>• Current signal is present and greater than 3 mA</li> </ul>								
<b>An Input 2 Loss</b>	<b>Analog input 2 current loss</b>								
29	<p><i>An Input 2 Loss</i> indicates that a current loss was detected in current mode on Analog input 2 (Terminal 7). In 4-20 mA and 20-4 mA modes loss of input is detected if the current falls below 3 mA.</p> <p><b>Recommended actions:</b></p> <ul style="list-style-type: none"> <li>• Check control wiring is correct</li> <li>• Check control wiring is undamaged</li> <li>• Check the <i>Analog Input 2 Mode</i> (07.011)</li> <li>• Current signal is present and greater than 3 mA</li> </ul>								
<b>An Output Calib</b>	<b>Analog output calibration failed</b>								
219	<p>The zero offset calibration of one or both of the analogue outputs has failed. This indicates that the drive hardware has failed or a voltage is applied to the output via a low impedance, possibly due to a wiring error. The failed output can be identified by the sub-trip number.</p> <table border="1"> <thead> <tr> <th>Sub-trip</th> <th>Reason</th> </tr> </thead> <tbody> <tr> <td>1</td> <td>Output 1 failed (Terminal 9)</td> </tr> <tr> <td>2</td> <td>Output 2 failed (Terminal 10)</td> </tr> </tbody> </table> <p><b>Recommended actions:</b></p> <ul style="list-style-type: none"> <li>• Check the wiring associated with analog outputs</li> <li>• Remove all the wiring that is connected to analog outputs and perform a re-calibration by power cycling the drive.</li> <li>• If trip persists replace the drive</li> </ul>	Sub-trip	Reason	1	Output 1 failed (Terminal 9)	2	Output 2 failed (Terminal 10)		
Sub-trip	Reason								
1	Output 1 failed (Terminal 9)								
2	Output 2 failed (Terminal 10)								
<b>App Menu Changed</b>	<b>Customization table for an application module has changed</b>								
217	<p>The <i>App Menu Changed</i> trip indicates that the customization table for an application menu has changed. The menu that has been changed can be identified by the sub-trip number.</p> <table border="1"> <thead> <tr> <th>Sub-trip</th> <th>Reason</th> </tr> </thead> <tbody> <tr> <td>1</td> <td>Menu 18</td> </tr> <tr> <td>2</td> <td>Menu 19</td> </tr> <tr> <td>3</td> <td>Menu 20</td> </tr> </tbody> </table> <p>If more than one menu has changed the lowest menu has priority. Drive user parameters must be saved to prevent this trip on the next power-up.</p> <p><b>Recommended actions:</b></p> <ul style="list-style-type: none"> <li>• Reset the trip and perform a parameter save to accept the new settings</li> </ul>	Sub-trip	Reason	1	Menu 18	2	Menu 19	3	Menu 20
Sub-trip	Reason								
1	Menu 18								
2	Menu 19								
3	Menu 20								
<b>Autotune 1</b>	<b>Position feedback did not change or required speed could not be reached</b>								
11	<p>The drive has tripped during an autotune. The cause of the trip can be identified from the sub-trip number.</p> <table border="1"> <thead> <tr> <th>Sub-trip</th> <th>Reason</th> </tr> </thead> <tbody> <tr> <td>1</td> <td>The position feedback did not change when position feedback is being used during rotating autotune.</td> </tr> <tr> <td>2</td> <td>The motor did not reach the required speed during rotating autotune or mechanical load measurement.</td> </tr> </tbody> </table> <p><b>Recommended actions:</b></p> <ul style="list-style-type: none"> <li>• Ensure the motor is free to turn i.e. mechanical brake was released</li> <li>• Ensure Pr <b>03.026</b> is set correctly (or appropriate 2<sup>nd</sup> motor map parameter)</li> <li>• Check feedback device wiring is correct</li> <li>• Check encoder mechanical coupling to the motor</li> </ul>	Sub-trip	Reason	1	The position feedback did not change when position feedback is being used during rotating autotune.	2	The motor did not reach the required speed during rotating autotune or mechanical load measurement.		
Sub-trip	Reason								
1	The position feedback did not change when position feedback is being used during rotating autotune.								
2	The motor did not reach the required speed during rotating autotune or mechanical load measurement.								

Trip	Diagnosis								
<b>Autotune 2</b>	<b>Position feedback direction incorrect</b>								
12	The drive has tripped during a rotating autotune. The cause of the trip can be identified from the associated sub-trip number.								
	<table border="1"> <thead> <tr> <th>Sub-trip</th> <th>Reason</th> </tr> </thead> <tbody> <tr> <td>1</td> <td>The position feedback direction is incorrect when position feedback is being used during a rotating autotune</td> </tr> <tr> <td>2</td> <td>A SINCOS encoder with comms is being used for position feedback and the comms position is rotating in the opposite direction to the sine wave based position.</td> </tr> </tbody> </table>	Sub-trip	Reason	1	The position feedback direction is incorrect when position feedback is being used during a rotating autotune	2	A SINCOS encoder with comms is being used for position feedback and the comms position is rotating in the opposite direction to the sine wave based position.		
	Sub-trip	Reason							
1	The position feedback direction is incorrect when position feedback is being used during a rotating autotune								
2	A SINCOS encoder with comms is being used for position feedback and the comms position is rotating in the opposite direction to the sine wave based position.								
<p><b>Recommended actions:</b></p> <ul style="list-style-type: none"> <li>• Check motor cable wiring is correct</li> <li>• Check feedback device wiring is correct</li> <li>• Swap any two motor phases</li> </ul>									
<b>Autotune 3</b>	<b>Measured inertia has exceeded the parameter range or commutation signals changed in wrong direction</b>								
13	The drive has tripped during a rotating autotune or mechanical load measurement test. The cause of the trip can be identified from the associated sub-trip number.								
	<table border="1"> <thead> <tr> <th>Sub-trip</th> <th>Reason</th> </tr> </thead> <tbody> <tr> <td>1</td> <td>Measured inertia has exceeded the parameter range during a mechanical load measurement</td> </tr> <tr> <td>2</td> <td>The commutation signals changed in the wrong direction during a rotating autotune</td> </tr> <tr> <td>3</td> <td>The mechanical load test has been unable to identify the motor inertia</td> </tr> </tbody> </table>	Sub-trip	Reason	1	Measured inertia has exceeded the parameter range during a mechanical load measurement	2	The commutation signals changed in the wrong direction during a rotating autotune	3	The mechanical load test has been unable to identify the motor inertia
	Sub-trip	Reason							
	1	Measured inertia has exceeded the parameter range during a mechanical load measurement							
2	The commutation signals changed in the wrong direction during a rotating autotune								
3	The mechanical load test has been unable to identify the motor inertia								
<p><b>Recommended actions for sub-trip 2:</b></p> <ul style="list-style-type: none"> <li>• Check motor cable wiring is correct</li> <li>• Check feedback device U,V and W commutation signal wiring is correct</li> </ul>									
<p><b>Recommended actions for sub-trip 3:</b></p> <ul style="list-style-type: none"> <li>• Increase the test level.</li> <li>• If the test was carried out at standstill repeat the test with the motor rotating within the recommended speed range.</li> </ul>									
<b>Autotune 7</b>	<b>Motor number of poles / position feedback resolution set incorrectly</b>								
17	An <i>Autotune 7</i> trip is initiated during a rotating autotune, if the motor poles or the position feedback resolution have been set up incorrectly where position feedback is being used.								
	<p><b>Recommended actions:</b></p> <ul style="list-style-type: none"> <li>• Check line per revolution for feedback device</li> <li>• Check the number of poles in Pr <b>05.011</b></li> </ul>								
<b>Autotune Stopped</b>	<b>Autotune test stopped before completion</b>								
18	The drive was prevented from completing an autotune test, because either the drive enable or the drive run were removed.								
	<p><b>Recommended actions:</b></p> <ul style="list-style-type: none"> <li>• Check the drive enable signal (Terminal 31) was active during the autotune</li> <li>• Check the run command was active in Pr <b>08.005</b> during autotune</li> </ul>								
<b>Brake R Too Hot</b>	<b>Braking resistor overload timed out (I<sup>2</sup>t)</b>								
19	The <i>Brake R Too Hot</i> indicates that braking resistor overload has timed out. The value in <i>Braking Resistor Thermal Accumulator</i> (10.039) is calculated using <i>Braking Resistor Rated Power</i> (10.030), <i>Braking Resistor Thermal Time Constant</i> (10.031) and <i>Braking Resistor Resistance</i> (10.061). The <i>Brake R Too Hot</i> trip is initiated when <i>Braking Resistor Thermal Accumulator</i> (10.039) reaches 100 %.								
	<p><b>Recommended actions:</b></p> <ul style="list-style-type: none"> <li>• Ensure the values entered in Pr <b>10.030</b>, Pr <b>10.031</b> and Pr <b>10.061</b> are correct</li> <li>• If an external thermal protection device is being used and the braking resistor software overload protection is not required, set Pr <b>10.030</b>, Pr <b>10.031</b> or Pr <b>10.061</b> to 0 to disable the trip.</li> </ul>								
<b>Card Access</b>	<b>NV Media Card Write fail</b>								
185	The <i>Card Access</i> trip indicates that the drive was unable to access the NV Media Card. If the trip occurs during the data transfer to the card then the file being written may be corrupted. If the trip occurs when the data being transferred to the drive then the data transfer may be incomplete. If a parameter file is transferred to the drive and this trip occurs during the transfer, the parameters are not saved to non-volatile memory, and so the original parameters can be restored by powering the drive down and up again.								
	<p><b>Recommended actions:</b></p> <ul style="list-style-type: none"> <li>• Check NV Media Card is installed / located correctly</li> <li>• Replace the NV Media Card</li> </ul>								

Trip	Diagnosis								
<b>Card Boot</b>	<b>The Menu 0 parameter modification cannot be saved to the NV Media Card</b>								
177	<p>Menu 0 changes are automatically saved on exiting edit mode.</p> <p>The <i>Card Boot</i> trip will occur if a write to a Menu 0 parameter has been initiated via the keypad by exiting edit mode and Pr <b>11.042</b> is set for auto or boot mode, but the necessary boot file has not been created on the NV Media Card to take the new parameter value. This occurs when Pr <b>11.042</b> is changed to Auto (3) or Boot (4) mode, but the drive is not subsequently reset.</p> <p><b>Recommended actions:</b></p> <ul style="list-style-type: none"> <li>• Ensure that Pr <b>11.042</b> is correctly set, and then reset the drive to create the necessary file on the NV Media Card</li> <li>• Re-attempt the parameter write to the Menu 0 parameter</li> </ul>								
<b>Card Busy</b>	<b>NV Media Card cannot be accessed as it is being accessed by an option module</b>								
178	<p>The <i>Card Busy</i> trip indicates that an attempt has been made to access a file on NV Media Card, but the NV Media Card is already being accessed by an option module. No data is transferred.</p> <p><b>Recommended actions:</b></p> <ul style="list-style-type: none"> <li>• Wait for the option module to finish accessing the NV Media Card and re-attempt the required function</li> </ul>								
<b>Card Compare</b>	<b>NV Media Card file/data is different to the one in the drive</b>								
188	<p>A compare has been carried out between a file on the NV Media Card, a Card Compare trip is initiated if the parameters on the NV Media Card are different to the drive.</p> <p><b>Recommended actions:</b></p> <ul style="list-style-type: none"> <li>• Set Pr <b>mm.000</b> to 0 and reset the trip</li> <li>• Check to ensure the correct data block on the NV Media Card has been used for the compare.</li> </ul>								
<b>Card Data Exists</b>	<b>NV Media Card data location already contains data</b>								
179	<p>The <i>Card Data Exists</i> trip indicates that an attempt has been made to store data on a NV Media Card in a data block which already contains data. The data should be erased from the card first to prevent this trip.</p> <p><b>Recommended actions:</b></p> <ul style="list-style-type: none"> <li>• Erase the data in data location</li> <li>• Write data to an alternative data location</li> </ul>								
<b>Card Drive Mode</b>	<b>NV Media Card parameter set not compatible with current drive mode</b>								
187	<p>The <i>Card Drive Mode</i> trip is produced during a compare if the drive mode in the data block on the NV Media Card is different from the current drive mode. This trip is also produced if an attempt is made to transfer parameters from a NV Media Card to the drive if the operating mode in the data block is outside the allowed range of operating modes.</p> <p><b>Recommended actions:</b></p> <ul style="list-style-type: none"> <li>• Ensure the destination drive supports the drive operating mode in the parameter file.</li> <li>• Clear the value in Pr <b>mm.000</b> and reset the drive</li> <li>• Ensure destination drive operating mode is the same as the source parameter file</li> </ul>								
<b>Card Error</b>	<b>NV Media Card data structure error</b>								
182	<p>The <i>Card Error</i> trip indicates that an attempt has been made to access a NV media card, but an error has been detected in the data structure on the card. Resetting this trip will cause the drive to erase the &lt;MCDF&gt; folder from the NV media card (if it exists) and create the correct folder structure. On an SD card, whilst this trip is still present, missing directories will be created, and if the header file is missing it will be created. The following sub-trip numbers are used with this trip:</p> <table border="1"> <thead> <tr> <th>Sub-trip</th> <th>Reason</th> </tr> </thead> <tbody> <tr> <td>1</td> <td>The required folder and file structure is not present</td> </tr> <tr> <td>2</td> <td>The &lt;000&gt; file is corrupted.</td> </tr> <tr> <td>3</td> <td>Two or more files in the &lt;MCDF\&gt; folder have the same file identification number.</td> </tr> </tbody> </table> <p><b>Recommended actions:</b></p> <ul style="list-style-type: none"> <li>• Erase all the data block and re-attempt the process</li> <li>• Ensure the card is located correctly</li> <li>• Replace the NV Media Card</li> </ul>	Sub-trip	Reason	1	The required folder and file structure is not present	2	The <000> file is corrupted.	3	Two or more files in the <MCDF\> folder have the same file identification number.
Sub-trip	Reason								
1	The required folder and file structure is not present								
2	The <000> file is corrupted.								
3	Two or more files in the <MCDF\> folder have the same file identification number.								
<b>Card Full</b>	<b>NV Media Card full</b>								
184	<p>The <i>Card Full</i> trip indicates that an attempt has been made to create a data block on a NV Media Card, but there is not enough space left on the card.</p> <p><b>Recommended actions:</b></p> <ul style="list-style-type: none"> <li>• Delete a data block or the entire NV Media Card to create space</li> <li>• Use a different NV Media Card</li> </ul>								

Trip	Diagnosis								
<b>Card No Data</b>	<b>NV Media Card data not found</b>								
183	<p>The <i>Card No Data</i> trip indicates that an attempt has been made to access non-existent file or block on a NV Media Card. No data is transferred.</p> <p><b>Recommended actions:</b></p> <ul style="list-style-type: none"> <li>• Ensure data block number is correct</li> </ul>								
<b>Card Option</b>	<b>NV Media Card trip; option modules installed are different between source drive and destination drive</b>								
180	<p>The <i>Card Option</i> trip indicates that parameter data or default difference data is being transferred from a NV Media Card to the drive, but the option module categories are different between source and destination drives. This trip does not stop the data transfer, but is a warning that the data for the option modules that are different will be set to the default values and not the values from the card. This trip also applies if a compare is attempted between the data block and the drive.</p> <p><b>Recommended actions:</b></p> <ul style="list-style-type: none"> <li>• Ensure the correct option modules are installed.</li> <li>• Ensure the option modules are in the same option module slot as the parameter set stored.</li> <li>• Press the red reset button to acknowledge that the parameters for one or more of the option modules installed will be at their default values</li> <li>• This trip can be suppressed by setting Pr <b>mm.000</b> to 9666 and resetting the drive.</li> </ul>								
<b>Card Product</b>	<b>NV Media Card data blocks are not compatible with the drive derivative</b>								
175	<p>If <i>Drive Derivative</i> (11.028) or <i>Product Type</i> (11.063) are different between the source and target drives then this trip is initiated either at power-up or when the card is accessed. It will have one of the following sub-trip numbers:</p> <table border="1"> <thead> <tr> <th>Sub-trip</th> <th>Reason</th> </tr> </thead> <tbody> <tr> <td>1</td> <td>If <i>Drive Derivative</i> (11.028) is different between the source and target drives, this trip is initiated either at power-up or when the SD Card is accessed. Data is still transferred, since this is a warning trip; the trip can be suppressed by entering code 9666 in parameter xx.000, and resetting the drive (this applies the warning suppression flag to the card).</td> </tr> <tr> <td>2</td> <td>If <i>Product Type</i> (11.063) is different between the source and target drives or if corruption is detected in the parameter file, this trip is initiated either at power-up or when the SD Card is accessed. This trip can be reset but no data are transferred in either direction between the drive and the card.</td> </tr> <tr> <td>3</td> <td>A Unidrive SP parameter value was found that has no equivalent parameter on the destination drive. Data is still transferred, since this is a warning trip; the trip can be suppressed by entering code 9666 in Pr <b>xx.000</b>, and resetting the drive (this applies the warning suppression flag to the card).</td> </tr> </tbody> </table> <p><b>Recommended actions:</b></p> <ul style="list-style-type: none"> <li>• Use a different NV Media Card</li> <li>• This trip can be suppressed by setting Pr <b>mm.000</b> to 9666 and resetting the drive</li> </ul>	Sub-trip	Reason	1	If <i>Drive Derivative</i> (11.028) is different between the source and target drives, this trip is initiated either at power-up or when the SD Card is accessed. Data is still transferred, since this is a warning trip; the trip can be suppressed by entering code 9666 in parameter xx.000, and resetting the drive (this applies the warning suppression flag to the card).	2	If <i>Product Type</i> (11.063) is different between the source and target drives or if corruption is detected in the parameter file, this trip is initiated either at power-up or when the SD Card is accessed. This trip can be reset but no data are transferred in either direction between the drive and the card.	3	A Unidrive SP parameter value was found that has no equivalent parameter on the destination drive. Data is still transferred, since this is a warning trip; the trip can be suppressed by entering code 9666 in Pr <b>xx.000</b> , and resetting the drive (this applies the warning suppression flag to the card).
Sub-trip	Reason								
1	If <i>Drive Derivative</i> (11.028) is different between the source and target drives, this trip is initiated either at power-up or when the SD Card is accessed. Data is still transferred, since this is a warning trip; the trip can be suppressed by entering code 9666 in parameter xx.000, and resetting the drive (this applies the warning suppression flag to the card).								
2	If <i>Product Type</i> (11.063) is different between the source and target drives or if corruption is detected in the parameter file, this trip is initiated either at power-up or when the SD Card is accessed. This trip can be reset but no data are transferred in either direction between the drive and the card.								
3	A Unidrive SP parameter value was found that has no equivalent parameter on the destination drive. Data is still transferred, since this is a warning trip; the trip can be suppressed by entering code 9666 in Pr <b>xx.000</b> , and resetting the drive (this applies the warning suppression flag to the card).								
<b>Card Rating</b>	<b>NV Media Card Trip; The voltage and / or current rating of the source and destination drives are different</b>								
186	<p>The <i>Card Rating</i> trip indicates that parameter data is being transferred from a NV Media Card to the drive, but the current and / or voltage ratings are different between source and destination drives. This trip also applies if a compare (using Pr <b>mm.000</b> set to 8yyy) is attempted between the data block on a NV Media Card and the drive. The <i>Card Rating</i> trip does not stop the data transfer but is a warning that rating specific parameters with the RA attribute may not be transferred to the destination drive.</p> <p><b>Recommended actions:</b></p> <ul style="list-style-type: none"> <li>• Reset the drive to clear the trip</li> <li>• Ensure that the drive rating dependent parameters have transferred correctly</li> <li>• This trip can be suppressed by setting Pr <b>mm.000</b> to 9666 and resetting the drive.</li> </ul>								
<b>Card Read Only</b>	<b>NV Media Card has the Read Only bit set</b>								
181	<p>The <i>Card Read Only</i> trip indicates that an attempt has been made to modify a read-only NV Media Card or a read-only data block. A NV Media Card is read-only if the read-only flag has been set.</p> <p><b>Recommended actions:</b></p> <ul style="list-style-type: none"> <li>• Clear the read only flag by setting Pr <b>mm.000</b> to 9777 and reset the drive. This will clear the read-only flag for all data blocks in the NV Media Card</li> <li>• This trip can be suppressed by setting Pr <b>mm.000</b> to 9666 and resetting the drive.</li> </ul>								
<b>Card Slot</b>	<b>NV Media Card Trip; Option module application program transfer has failed</b>								
174	<p>The <i>Card Slot</i> trip is initiated, if the transfer of an option module application program to or from an application module failed because the option module does not respond correctly. If this happens this trip is produced with the sub-trip indicating the option module slot number.</p> <p><b>Recommended actions:</b></p> <ul style="list-style-type: none"> <li>• Ensure the source / destination option module is installed on the correct slot</li> </ul>								

Trip	Diagnosis								
<b>Configuration</b>	<b>The number of power modules installed is different from the modules expected</b>								
111	<p>The <i>Configuration</i> trip indicates that the <i>Number Of Power Modules Detected</i> (11.071) does not match the previous value stored. The sub-trip value indicates the number of power modules expected.</p> <p><b>Recommended actions:</b></p> <ul style="list-style-type: none"> <li>• Ensure that all the power modules are correctly connected</li> <li>• Ensure all the power modules have powered up correctly</li> <li>• Ensure that the value in Pr <b>11.071</b> is set to the number of power modules connected</li> <li>• Set Pr <b>11.035</b> to 0 to disable the trip if it is not required</li> </ul> <p>This trip is also initiated if the number of external rectifiers connected to each power module is less than the number defined by <i>Number Of Rectifiers Expected</i> (11.096). If this is the reason for the trip the sub-trip is 10x where x is the number of external rectifiers that should be connected.</p> <p><b>Recommended actions:</b></p> <ul style="list-style-type: none"> <li>• Ensure that all the external rectifiers are connected correctly.</li> <li>• Ensure that the value in <i>Number Of Rectifiers Expected</i> (11.096) is correct.</li> </ul>								
<b>Control Word</b>	<b>Trip initiated from the Control Word (06.042)</b>								
35	<p>The <i>Control Word</i> trip is initiated by setting bit 12 on the control word in Pr <b>06.042</b> when the control word is enabled (Pr <b>06.043</b> = On).</p> <p><b>Recommended actions:</b></p> <ul style="list-style-type: none"> <li>• Check the value of Pr <b>06.042</b>.</li> <li>• Disable the control word in <i>Control Word Enable</i> (Pr <b>06.043</b>)</li> </ul> <p>Bit 12 of the control word set to a one causes the drive to trip on Control Word</p> <p>When the control word is enabled, the trip can only be cleared by setting bit 12 to zero</p>								
<b>Current Offset</b>	<b>Current feedback offset error</b>								
225	<p>The current feedback offset is too large to be trimmed correctly. The sub-trip relates to the output phase for which the offset error has been detected.</p> <table border="1"> <thead> <tr> <th>Sub-trip</th> <th>Phase</th> </tr> </thead> <tbody> <tr> <td>1</td> <td>U</td> </tr> <tr> <td>2</td> <td>V</td> </tr> <tr> <td>3</td> <td>W</td> </tr> </tbody> </table> <p><b>Recommended actions:</b></p> <ul style="list-style-type: none"> <li>• Ensure that there is no possibility of current flowing in the output phases of the drive when the drive is not enabled</li> <li>• Hardware fault – Contact the supplier of the drive</li> </ul>	Sub-trip	Phase	1	U	2	V	3	W
Sub-trip	Phase								
1	U								
2	V								
3	W								
<b>Data Changing</b>	<b>Drive parameters are being changed</b>								
97	<p>A user action or a file system write is active that is changing the drive parameters and the drive has been commanded to enable, i.e. <i>Drive Active</i> (10.002) = 1. The user actions that change drive parameters are loading defaults, changing drive mode, or transferring data from an NV memory card or a position feedback device to the drive. The file system actions that will cause this trip to be initiated if the drive is enabled during the transfer are writing a parameter or macro file to the drive, or transferring a derivative or user program to the drive. It should be noted that none of these actions can be started if the drive is active, and so the trip only occurs if the action is started and then the drive is enabled.</p> <p><b>Recommended actions:</b></p> <p>Ensure the drive is not enabled when one of the following is being carried out:</p> <ul style="list-style-type: none"> <li>• Loading defaults</li> <li>• Changing drive mode</li> <li>• Transferring data from NV Media Card or position feedback device</li> <li>• Transferring user programs</li> </ul>								
<b>Derivative ID</b>	<b>There is a problem with the identifier associated with derivative image which customizes the drive.</b>								
247	<p>There is a problem with the identifier associated with derivative image which customizes the drive. The reason for the trip is given by the sub-trip as follows:</p> <table border="1"> <thead> <tr> <th>Sub-trip</th> <th>Reason</th> </tr> </thead> <tbody> <tr> <td>1</td> <td>There should be a derivative image in the product but this has been erased.</td> </tr> <tr> <td>2</td> <td>The identifier is out of range.</td> </tr> <tr> <td>3</td> <td>The derivative image has been changed.</td> </tr> </tbody> </table>	Sub-trip	Reason	1	There should be a derivative image in the product but this has been erased.	2	The identifier is out of range.	3	The derivative image has been changed.
Sub-trip	Reason								
1	There should be a derivative image in the product but this has been erased.								
2	The identifier is out of range.								
3	The derivative image has been changed.								

Trip	Diagnosis																														
<b>Derivative Image</b>	<b>Derivative Image error</b>																														
248	The <i>Derivative Image</i> trip indicates that an error has been detected in the derivative image. The sub-trip number indicates the reason for the trip.																														
	<table border="1"> <thead> <tr> <th>Sub-trip</th> <th>Reason</th> <th>Comments</th> </tr> </thead> <tbody> <tr> <td>1 to 52</td> <td>An error has been detected in the derivative image, contact the supplier of the drive.</td> <td></td> </tr> <tr> <td>61</td> <td>The option module fitted in slot 1 is not allowed with the derivative image</td> <td rowspan="4">Occurs when the drive powers-up or the image is programmed. The image tasks will not run.</td> </tr> <tr> <td>62</td> <td>The option module fitted in slot 2 is not allowed with the derivative image</td> </tr> <tr> <td>63</td> <td>The option module fitted in slot 3 is not allowed with the derivative image</td> </tr> <tr> <td>64</td> <td>The option module fitted in slot 4 is not allowed with the derivative image</td> </tr> <tr> <td>70</td> <td>An option module that is required by the derivative image is not fitted in any slot</td> <td rowspan="4">Occurs when the drive powers-up or the image is programmed. The image tasks will not run.</td> </tr> <tr> <td>71</td> <td>An option module specifically required to be fitted in slot 1 not present</td> </tr> <tr> <td>72</td> <td>An option module specifically required to be fitted in slot 2 not present</td> </tr> <tr> <td>73</td> <td>An option module specifically required to be fitted in slot 3 not present</td> </tr> <tr> <td>74</td> <td>An option module specifically required to be fitted in slot 4 not present</td> <td></td> </tr> <tr> <td>80 to 81</td> <td>An error has been detected in the derivative image, contact the supplier of the drive.</td> <td></td> </tr> </tbody> </table>	Sub-trip	Reason	Comments	1 to 52	An error has been detected in the derivative image, contact the supplier of the drive.		61	The option module fitted in slot 1 is not allowed with the derivative image	Occurs when the drive powers-up or the image is programmed. The image tasks will not run.	62	The option module fitted in slot 2 is not allowed with the derivative image	63	The option module fitted in slot 3 is not allowed with the derivative image	64	The option module fitted in slot 4 is not allowed with the derivative image	70	An option module that is required by the derivative image is not fitted in any slot	Occurs when the drive powers-up or the image is programmed. The image tasks will not run.	71	An option module specifically required to be fitted in slot 1 not present	72	An option module specifically required to be fitted in slot 2 not present	73	An option module specifically required to be fitted in slot 3 not present	74	An option module specifically required to be fitted in slot 4 not present		80 to 81	An error has been detected in the derivative image, contact the supplier of the drive.	
	Sub-trip	Reason	Comments																												
	1 to 52	An error has been detected in the derivative image, contact the supplier of the drive.																													
	61	The option module fitted in slot 1 is not allowed with the derivative image	Occurs when the drive powers-up or the image is programmed. The image tasks will not run.																												
	62	The option module fitted in slot 2 is not allowed with the derivative image																													
	63	The option module fitted in slot 3 is not allowed with the derivative image																													
	64	The option module fitted in slot 4 is not allowed with the derivative image																													
	70	An option module that is required by the derivative image is not fitted in any slot	Occurs when the drive powers-up or the image is programmed. The image tasks will not run.																												
	71	An option module specifically required to be fitted in slot 1 not present																													
	72	An option module specifically required to be fitted in slot 2 not present																													
	73	An option module specifically required to be fitted in slot 3 not present																													
	74	An option module specifically required to be fitted in slot 4 not present																													
80 to 81	An error has been detected in the derivative image, contact the supplier of the drive.																														
	<b>Recommended action:</b> Contact the supplier of the drive																														
<b>Destination</b>	<b>Two or more parameters are writing to the same destination parameter</b>																														
199	The <i>Destination</i> trip indicates that destination output parameters of two or more logic functions (Menus 5, 7, 8, 9, 12 or 14) within the drive are writing to the same parameter. <b>Recommended actions:</b> <ul style="list-style-type: none"> <li>Set Pr <b>mm.000</b> to 'Destinations' or 12001 and check all visible parameters in all menus for parameter write conflicts</li> </ul>																														
<b>Drive Size</b>	<b>Power stage recognition: Unrecognized drive size</b>																														
224	The <i>Drive Size</i> trip indicates that the control PCB has not recognized the drive size of the power circuit to which it is connected. <b>Recommended action:</b> <ul style="list-style-type: none"> <li>Ensure the drive is programmed to the latest firmware version</li> <li>Hardware fault - return drive to supplier</li> </ul>																														

Trip	Diagnosis																				
<b>EEPROM Fail</b>	<b>Default parameters have been loaded</b>																				
31	<p>The <i>EEPROM Fail</i> trip indicates that default parameters have been loaded. The exact cause/reason of the trip can be identified from the sub-trip number.</p> <table border="1"> <thead> <tr> <th>Sub-trip</th> <th>Reason</th> </tr> </thead> <tbody> <tr> <td>1</td> <td>The most significant digit of the internal parameter database version number has changed</td> </tr> <tr> <td>2</td> <td>The CRC's applied to the parameter data stored in internal non-volatile memory indicate that a valid set of parameters cannot be loaded</td> </tr> <tr> <td>3</td> <td>The drive mode restored from internal non-volatile memory is outside the allowed range for the product or the derivative image does not allow the previous drive mode</td> </tr> <tr> <td>4</td> <td>The drive derivative image has changed</td> </tr> <tr> <td>5</td> <td>The power stage hardware has changed</td> </tr> <tr> <td>6</td> <td>The internal I/O hardware has changed</td> </tr> <tr> <td>7</td> <td>The position feedback interface hardware has changed</td> </tr> <tr> <td>8</td> <td>The control board hardware has changed</td> </tr> <tr> <td>9</td> <td>The checksum on the non-parameter area of the EEPROM has failed</td> </tr> </tbody> </table> <p>The drive holds two banks of user save parameters and two banks of power down save parameters in non-volatile memory. If the last bank of either set of parameters that was saved is corrupted a User Save or Power Down Save trip is produced. If one of these trips occurs the parameters values that were last saved successfully are used. It can take some time to save parameters when requested by the user and if the power is removed from the drive during this process it is possible to corrupt the data in the non-volatile memory.</p> <p>If both banks of user save parameters or both banks of power down save parameters are corrupted or one of the other conditions given in the table above occurs EEPROM Fail.xxx trip is produced. If this trip occurs it is not possible to use the data that has been saved previously, and so the drive will be in lowest allowed drive mode with default parameters. The trip can only be reset if Pr <b>mm.000</b> (mm.000) is set to 10, 11, 1233 or 1244 or if <i>Load Defaults</i> (11.043) is set to a non-zero value.</p> <p><b>Recommended actions:</b></p> <ul style="list-style-type: none"> <li>• Default the drive and perform a reset</li> <li>• Allow sufficient time to perform a save before the supply to the drive is removed</li> <li>• If the trip persists - return drive to supplier</li> </ul>	Sub-trip	Reason	1	The most significant digit of the internal parameter database version number has changed	2	The CRC's applied to the parameter data stored in internal non-volatile memory indicate that a valid set of parameters cannot be loaded	3	The drive mode restored from internal non-volatile memory is outside the allowed range for the product or the derivative image does not allow the previous drive mode	4	The drive derivative image has changed	5	The power stage hardware has changed	6	The internal I/O hardware has changed	7	The position feedback interface hardware has changed	8	The control board hardware has changed	9	The checksum on the non-parameter area of the EEPROM has failed
	Sub-trip	Reason																			
	1	The most significant digit of the internal parameter database version number has changed																			
	2	The CRC's applied to the parameter data stored in internal non-volatile memory indicate that a valid set of parameters cannot be loaded																			
	3	The drive mode restored from internal non-volatile memory is outside the allowed range for the product or the derivative image does not allow the previous drive mode																			
	4	The drive derivative image has changed																			
	5	The power stage hardware has changed																			
	6	The internal I/O hardware has changed																			
	7	The position feedback interface hardware has changed																			
	8	The control board hardware has changed																			
9	The checksum on the non-parameter area of the EEPROM has failed																				
<b>Encoder 9</b>	<b>Position feedback is selected from a option module slot which does not have a feedback option module installed</b>																				
197	<p>The <i>Encoder 9</i> trip indicates that position feedback source selected in Pr <b>03.026</b> (or Pr <b>21.021</b> for the second motor map) is not valid</p> <p><b>Recommended actions:</b></p> <ul style="list-style-type: none"> <li>• Check the setting of Pr <b>03.026</b> (or Pr <b>21.021</b> if the second motor parameters have been enabled)</li> <li>• Ensure that the option slot selected in Pr <b>03.026</b> has a feedback option module installed</li> </ul>																				
<b>External Trip</b>	<b>An External trip is initiated</b>																				
6	<p>An <i>External Trip</i> has occurred. The cause of the trip can be identified from the sub trip number displayed after the trip string. See table below. An external trip can also be initiated by writing a value of 6 in Pr <b>10.038</b>.</p> <table border="1"> <thead> <tr> <th>Sub-trip</th> <th>Reason</th> </tr> </thead> <tbody> <tr> <td>1</td> <td><i>External Trip Mode</i> (08.010) = 1 or 3 and Safe Torque Off input 1 is low</td> </tr> <tr> <td>2</td> <td><i>External Trip Mode</i> (08.010) = 2 or 3 and Safe Torque Off input 2 is low</td> </tr> <tr> <td>3</td> <td><i>External Trip</i> (10.032) = 1</td> </tr> </tbody> </table> <p><b>Recommended actions:</b></p> <ul style="list-style-type: none"> <li>• Check the Safe Torque Off signal voltage on terminal 31 equals to 24 V</li> <li>• Check the value of Pr <b>08.009</b> which indicates the digital state of terminal 31, equates to 'on'.</li> <li>• If external trip detection of the Safe Torque Off input is not required, set Pr <b>08.010</b> to Off (0).</li> <li>• Check the value of Pr <b>10.032</b>.</li> <li>• Select 'Destinations' (or enter 12001) in Pr <b>mm.000</b> and check for a parameter controlling Pr <b>10.032</b>.</li> <li>• Ensure Pr <b>10.032</b> or Pr <b>10.038</b> (= 6) is not being controlled by serial comms</li> </ul>	Sub-trip	Reason	1	<i>External Trip Mode</i> (08.010) = 1 or 3 and Safe Torque Off input 1 is low	2	<i>External Trip Mode</i> (08.010) = 2 or 3 and Safe Torque Off input 2 is low	3	<i>External Trip</i> (10.032) = 1												
	Sub-trip	Reason																			
	1	<i>External Trip Mode</i> (08.010) = 1 or 3 and Safe Torque Off input 1 is low																			
	2	<i>External Trip Mode</i> (08.010) = 2 or 3 and Safe Torque Off input 2 is low																			
3	<i>External Trip</i> (10.032) = 1																				
<b>HF01</b>	<b>Data processing error: CPU address error</b>																				
	<p>The <i>HF01</i> trip indicates that a CPU address error has occurred. This trip indicates that the control PCB on the drive has failed.</p> <p><b>Recommended actions:</b></p> <ul style="list-style-type: none"> <li>• Hardware fault – Contact the supplier of the drive</li> </ul>																				

Trip	Diagnosis
<b>HF02</b>	<b>Data processing error: DMAC address error</b>
	The <i>HF02</i> trip indicates that a DMAC address error has occurred. This trip indicates that the control PCB on the drive has failed. <b>Recommended actions:</b> <ul style="list-style-type: none"> <li>Hardware fault – Contact the supplier of the drive</li> </ul>
<b>HF03</b>	<b>Data processing error: Illegal instruction</b>
	The <i>HF03</i> trip indicates that an illegal instruction has occurred. This trip indicates that the control PCB on the drive has failed. <b>Recommended actions:</b> <ul style="list-style-type: none"> <li>Hardware fault – Contact the supplier of the drive</li> </ul>
<b>HF04</b>	<b>Data processing error: Illegal slot instruction</b>
	The <i>HF04</i> trip indicates that an illegal slot instruction has occurred. This trip indicates that the control PCB on the drive has failed. <b>Recommended actions:</b> <ul style="list-style-type: none"> <li>Hardware fault – Contact the supplier of the drive</li> </ul>
<b>HF05</b>	<b>Data processing error: Undefined exception</b>
	The <i>HF05</i> trip indicates that an undefined exception error has occurred. This trip indicates that the control PCB on the drive has failed. <b>Recommended actions:</b> <ul style="list-style-type: none"> <li>Hardware fault – Contact the supplier of the drive</li> </ul>
<b>HF06</b>	<b>Data processing error: Reserved exception</b>
	The <i>HF06</i> trip indicates that a reserved exception error has occurred. This trip indicates that the control PCB on the drive has failed. <b>Recommended actions:</b> <ul style="list-style-type: none"> <li>Hardware fault – Contact the supplier of the drive</li> </ul>
<b>HF07</b>	<b>Data processing error: Watchdog failure</b>
	The <i>HF07</i> trip indicates that a watchdog failure has occurred. This trip indicates that the control PCB on the drive has failed. <b>Recommended actions:</b> <ul style="list-style-type: none"> <li>Hardware fault – Contact the supplier of the drive</li> </ul>
<b>HF08</b>	<b>Data processing error: CPU interrupt crash</b>
	The <i>HF08</i> trip indicates that a CPU interrupt crash has occurred. This trip indicates that the control PCB on the drive has failed. <b>Recommended actions:</b> <ul style="list-style-type: none"> <li>Hardware fault – Contact the supplier of the drive</li> </ul>
<b>HF09</b>	<b>Data processing error: Free store overflow</b>
	The <i>HF09</i> trip indicates that a free store overflow has occurred. This trip indicates that the control PCB on the drive has failed. <b>Recommended actions:</b> <ul style="list-style-type: none"> <li>Hardware fault – Contact the supplier of the drive</li> </ul>
<b>HF10</b>	<b>Data processing error: Parameter routing system error</b>
	The <i>HF10</i> trip indicates that a Parameter routing system error has occurred. This trip indicates that the control PCB on the drive has failed. <b>Recommended actions:</b> <ul style="list-style-type: none"> <li>Hardware fault – Contact the supplier of the drive</li> </ul>
<b>HF11</b>	<b>Data processing error: Access to EEPROM failed</b>
	The <i>HF11</i> trip indicates that access to the drive EEPROM has failed. This trip indicates that the control PCB on the drive has failed. <b>Recommended actions:</b> <ul style="list-style-type: none"> <li>Hardware fault – Contact the supplier of the drive</li> </ul>

Trip	Diagnosis																				
<b>HF12</b>	<p><b>Data processing error: Main program stack overflow</b></p> <p>The <i>HF12</i> trip indicates that the main program stack over flow has occurred. The stack can be identified by the sub-trip number. This trip indicates that the control PCB on the drive has failed.</p> <table border="1"> <thead> <tr> <th>Sub-trip</th> <th>Stack</th> </tr> </thead> <tbody> <tr> <td>1</td> <td>Background tasks</td> </tr> <tr> <td>2</td> <td>Timed tasks</td> </tr> <tr> <td>3</td> <td>Main system interrupts</td> </tr> </tbody> </table> <p><b>Recommended actions:</b></p> <ul style="list-style-type: none"> <li>Hardware fault – Contact the supplier of the drive</li> </ul>	Sub-trip	Stack	1	Background tasks	2	Timed tasks	3	Main system interrupts												
Sub-trip	Stack																				
1	Background tasks																				
2	Timed tasks																				
3	Main system interrupts																				
<b>HF13</b>	<p><b>Data processing error: Firmware incompatible with hardware</b></p> <p>The <i>HF13</i> trip indicates that the drive firmware is not compatible with the hardware. This trip indicates that the control PCB on the drive has failed. The sub-trip number gives the actual ID code of the control board hardware.</p> <p><b>Recommended actions:</b></p> <ul style="list-style-type: none"> <li>Re-program the drive with the latest version of the drive firmware</li> <li>Hardware fault – Contact the supplier of the drive</li> </ul>																				
<b>HF14</b>	<p><b>Data processing error: CPU register bank error</b></p> <p>The <i>HF14</i> trip indicates that a CPU register bank error has occurred. This trip indicates that the control PCB on the drive has failed.</p> <p><b>Recommended actions:</b></p> <ul style="list-style-type: none"> <li>Hardware fault – Contact the supplier of the drive</li> </ul>																				
<b>HF15</b>	<p><b>Data processing error: CPU divide error</b></p> <p>The <i>HF15</i> trip indicates that a CPU divide error has occurred. This trip indicates that the control PCB on the drive has failed.</p> <p><b>Recommended actions:</b></p> <ul style="list-style-type: none"> <li>Hardware fault – Contact the supplier of the drive</li> </ul>																				
<b>HF16</b>	<p><b>Data processing error: RTOS error</b></p> <p>The <i>HF16</i> trip indicates that a RTOS error has occurred. This trip indicates that the control PCB on the drive has failed.</p> <p><b>Recommended actions:</b></p> <ul style="list-style-type: none"> <li>Hardware fault – Contact the supplier of the drive</li> </ul>																				
<b>HF17</b>	<p><b>Data processing error: Clock supplied to the control board is out of specification</b></p> <p>The <i>HF17</i> trip indicates that the clock supplied to the control board logic is out of specification. This trip indicates that the control PCB on the drive has failed.</p> <p><b>Recommended actions:</b></p> <ul style="list-style-type: none"> <li>Hardware fault – Contact the supplier of the drive</li> </ul>																				
<b>HF18</b>	<p><b>Data processing error: Internal flash memory has failed</b></p> <p>The <i>HF18</i> trip indicates that the internal flash memory has failed when writing option module parameter data. The reason for the trip can be identified by the sub-trip number.</p> <table border="1"> <thead> <tr> <th>Sub-trip</th> <th>Reason</th> </tr> </thead> <tbody> <tr> <td>1</td> <td>Option module initialization timed out</td> </tr> <tr> <td>2</td> <td>Programming error while writing menu in flash</td> </tr> <tr> <td>3</td> <td>Erase flash block containing setup menus failed</td> </tr> <tr> <td>4</td> <td>Erase flash block containing application menus failed</td> </tr> <tr> <td>5</td> <td>Incorrect setup menu CRC contained in flash</td> </tr> <tr> <td>6</td> <td>Incorrect application menu CRC contained in flash</td> </tr> <tr> <td>7</td> <td>Incorrect common application menu 18 CRC contained in flash</td> </tr> <tr> <td>8</td> <td>Incorrect common application menu 19 CRC contained in flash</td> </tr> <tr> <td>9</td> <td>Incorrect common application menu 20 CRC contained in flash</td> </tr> </tbody> </table> <p><b>Recommended actions:</b></p> <ul style="list-style-type: none"> <li>Hardware fault - Contact the supplier of the drive.</li> </ul>	Sub-trip	Reason	1	Option module initialization timed out	2	Programming error while writing menu in flash	3	Erase flash block containing setup menus failed	4	Erase flash block containing application menus failed	5	Incorrect setup menu CRC contained in flash	6	Incorrect application menu CRC contained in flash	7	Incorrect common application menu 18 CRC contained in flash	8	Incorrect common application menu 19 CRC contained in flash	9	Incorrect common application menu 20 CRC contained in flash
Sub-trip	Reason																				
1	Option module initialization timed out																				
2	Programming error while writing menu in flash																				
3	Erase flash block containing setup menus failed																				
4	Erase flash block containing application menus failed																				
5	Incorrect setup menu CRC contained in flash																				
6	Incorrect application menu CRC contained in flash																				
7	Incorrect common application menu 18 CRC contained in flash																				
8	Incorrect common application menu 19 CRC contained in flash																				
9	Incorrect common application menu 20 CRC contained in flash																				
<b>HF19</b>	<p><b>Data processing error: CRC check on the firmware has failed</b></p> <p>The <i>HF19</i> trip indicates that the CRC check on the drive firmware has failed.</p> <p><b>Recommended actions:</b></p> <ul style="list-style-type: none"> <li>Re-program the drive</li> <li>Hardware fault - Contact the supplier of the drive</li> </ul>																				

Trip	Diagnosis																				
<b>HF20</b>	<b>Data processing error: ASIC is not compatible with the hardware</b>																				
	The <i>HF20</i> trip indicates that the ASIC version is not compatible with the drive firmware. The ASIC version can be identified from the sub-trip number. <b>Recommended actions:</b> <ul style="list-style-type: none"> <li>Hardware fault - Contact the supplier of the drive</li> </ul>																				
<b>HF23 to HF25</b>	<b>Hardware fault</b>																				
	<b>Recommended actions:</b> <ul style="list-style-type: none"> <li>Hardware fault - Contact the supplier of the drive</li> </ul>																				
<b>I/O Overload</b>	<b>Digital output overload</b>																				
<b>26</b>	The <i>I/O Overload</i> trip indicates that the total current drawn from 24 V user supply or from the digital output has exceeded the limit. A trip is initiated if one or more of the following conditions: <ul style="list-style-type: none"> <li>Maximum output current from one digital output is 100 mA.</li> <li>The combined maximum output current from outputs 1 and 2 is 100 mA</li> <li>The combined maximum output current from output 3 and +24 V output is 100 mA</li> </ul> <b>Recommended actions:</b> <ul style="list-style-type: none"> <li>Check total loads on digital outputs</li> <li>Check control wiring is correct</li> <li>Check output wiring is undamaged</li> </ul>																				
<b>Inductance</b>	<b>This trip occurs in RFC-S mode when the drive has detected that the motor inductances are not suitable.</b>																				
<b>8</b>	This trip occurs in RFC-S mode when the drive has detected that the motor inductances are not suitable for the operation being attempted. The trip is either caused because the ratio or difference between Ld and Lq is too small or because the saturation characteristic of the motor cannot be measured. If the inductance ratio or difference is too small this is because one of the following conditions is true: $(No\text{-}load\ Lq\ (05.072) - Ld\ (05.024)) / Ld\ (05.024) < 0.1$ $(No\text{-}load\ Lq\ (05.072) - Ld\ (05.024)) < (K / Full\ Scale\ Current\ Kc\ (11.061))H$ where: <table border="1" style="margin-left: 20px;"> <thead> <tr> <th>Drive Rated voltage (11.033)</th> <th>K</th> </tr> </thead> <tbody> <tr> <td>200 V</td> <td>0.0073</td> </tr> <tr> <td>400 V</td> <td>0.0146</td> </tr> <tr> <td>575 V</td> <td>0.0174</td> </tr> <tr> <td>690 V</td> <td>0.0209</td> </tr> </tbody> </table> If the saturation characteristic of the motor cannot be measured this is because when the flux in the motor is changed the measured value of Ld does change sufficiently due to saturation to be measured. When half of <i>Rated Current</i> (05.007) is applied in the d axis of the motor in each direction the inductance must fall change at least $(K / (2 \times Full\ Scale\ Current\ Kc\ (11.061)))H$ . The specific reasons for each of the sub-trips and recommended actions are given in the table below. <table border="1" style="margin-left: 20px;"> <thead> <tr> <th>Sub-trip</th> <th>Reason</th> </tr> </thead> <tbody> <tr> <td>1</td> <td>The inductance ratio or difference is too small when the drive has been started in sensorless mode.</td> </tr> <tr> <td>2</td> <td>The saturation characteristic of the motor cannot be measured when the drive has been started in sensorless mode.</td> </tr> <tr> <td>3</td> <td>The inductance ratio or difference is too small when an attempt is made to determine the location of the motor flux during a stationary auto-tune in RFC-S mode. This trip is also produced when the inductance ratio or inductance difference is too small when carrying out a phasing test on starting in RFC-S mode. If position feedback is being used the measured value for <i>Position Feedback Phase Angle</i> (03.025) may not be reliable. Also the measured values of <i>Ld</i> (05.024) and <i>No-load Lq</i> (05.072) may not correspond to the d and q axis respectively.</td> </tr> <tr> <td>4</td> <td>The direction of the flux in the motor is detected by the change of inductance with different currents. This trip is initiated if the change cannot be detected when an attempt is made to perform a stationary auto-tune when position feedback is being used, or to perform a phasing test on starting in RFC-S mode.</td> </tr> </tbody> </table> <b>Recommended actions for sub-trip 1:</b> <ul style="list-style-type: none"> <li>Ensure that RFC Low Speed Mode (05.064) is set to Non-salient (1), Current (2) or Current No test (3).</li> </ul> <b>Recommended Actions For Sub-trip 2:</b> <ul style="list-style-type: none"> <li>Ensure that RFC Low Speed Mode (05.064) is set to Non-salient (1), Current (2) or Current No test (3).</li> </ul> <b>Recommended actions for sub-trip 3:</b> <ul style="list-style-type: none"> <li>None. The trip acts as a warning.</li> </ul> <b>Recommended actions for sub-trip 4:</b> <ul style="list-style-type: none"> <li>Stationary autotune is not possible. Perform a minimal movement or rotating autotune.</li> <li>Phasing test on starting is not possible. Use a position feedback device with commutation signals or absolute position.</li> </ul>	Drive Rated voltage (11.033)	K	200 V	0.0073	400 V	0.0146	575 V	0.0174	690 V	0.0209	Sub-trip	Reason	1	The inductance ratio or difference is too small when the drive has been started in sensorless mode.	2	The saturation characteristic of the motor cannot be measured when the drive has been started in sensorless mode.	3	The inductance ratio or difference is too small when an attempt is made to determine the location of the motor flux during a stationary auto-tune in RFC-S mode. This trip is also produced when the inductance ratio or inductance difference is too small when carrying out a phasing test on starting in RFC-S mode. If position feedback is being used the measured value for <i>Position Feedback Phase Angle</i> (03.025) may not be reliable. Also the measured values of <i>Ld</i> (05.024) and <i>No-load Lq</i> (05.072) may not correspond to the d and q axis respectively.	4	The direction of the flux in the motor is detected by the change of inductance with different currents. This trip is initiated if the change cannot be detected when an attempt is made to perform a stationary auto-tune when position feedback is being used, or to perform a phasing test on starting in RFC-S mode.
Drive Rated voltage (11.033)	K																				
200 V	0.0073																				
400 V	0.0146																				
575 V	0.0174																				
690 V	0.0209																				
Sub-trip	Reason																				
1	The inductance ratio or difference is too small when the drive has been started in sensorless mode.																				
2	The saturation characteristic of the motor cannot be measured when the drive has been started in sensorless mode.																				
3	The inductance ratio or difference is too small when an attempt is made to determine the location of the motor flux during a stationary auto-tune in RFC-S mode. This trip is also produced when the inductance ratio or inductance difference is too small when carrying out a phasing test on starting in RFC-S mode. If position feedback is being used the measured value for <i>Position Feedback Phase Angle</i> (03.025) may not be reliable. Also the measured values of <i>Ld</i> (05.024) and <i>No-load Lq</i> (05.072) may not correspond to the d and q axis respectively.																				
4	The direction of the flux in the motor is detected by the change of inductance with different currents. This trip is initiated if the change cannot be detected when an attempt is made to perform a stationary auto-tune when position feedback is being used, or to perform a phasing test on starting in RFC-S mode.																				

Trip	Diagnosis						
<b>Inductor Too Hot</b>	<b>The regen inductor has overloaded</b>						
93	<p>In Regen mode, this trip indicates a regen inductor thermal overload based on the <i>Rated Current</i> (Pr <b>05.007</b>) and the <i>Inductor Thermal Time Constant</i> (Pr <b>04.015</b>). Pr <b>04.019</b> displays the inductor temperature as a percentage of the maximum value. The drive will trip on <i>Inductor Too Hot</i> when Pr <b>04.019</b> gets to 100 %.</p> <p><b>Recommended actions:</b></p> <ul style="list-style-type: none"> <li>• Check the load / current through the inductor has not changed.</li> <li>• Ensure the <i>Rated Current</i> (Pr <b>05.007</b>) is not zero.</li> </ul>						
<b>Inter-connect</b>	<b>Multi-power module drive interconnection cable error</b>						
103	<p>The sub-trip "xx.0.00" indicates which power module has detected the fault where xx is the power module number. It should be noted that this trip is also initiated if the communication fails either when a rectifier signals a fault or a trip is reset. In this case, the sub-trip is the number of modules that are still communicating correctly.</p>						
<b>Island</b>	<b>Island condition detected in regen mode</b>						
160	<p>The <i>Island</i> trip indicates that the AC mains is no longer present and the inverter would be on 'islanded' power supply if it continued to operate.</p> <p>The sub-trips indicate the reason for the trip:</p> <table border="1"> <thead> <tr> <th>Sub-trip</th> <th>Description</th> </tr> </thead> <tbody> <tr> <td>1</td> <td>Island detection system has been enabled and detected an island condition</td> </tr> <tr> <td>2</td> <td>The minimum synchronization voltage is non-zero and the supply voltage has been below this threshold and been simulating its own supply synchronization for more than 2.0 s.</td> </tr> </tbody> </table> <p><b>Recommended actions:</b></p> <ul style="list-style-type: none"> <li>• Check the supply / supply connections to the regen drive</li> </ul>	Sub-trip	Description	1	Island detection system has been enabled and detected an island condition	2	The minimum synchronization voltage is non-zero and the supply voltage has been below this threshold and been simulating its own supply synchronization for more than 2.0 s.
Sub-trip	Description						
1	Island detection system has been enabled and detected an island condition						
2	The minimum synchronization voltage is non-zero and the supply voltage has been below this threshold and been simulating its own supply synchronization for more than 2.0 s.						
<b>Keypad Mode</b>	<b>Keypad has been removed when the drive is receiving the speed reference from the keypad</b>						
34	<p>The <i>Keypad Mode</i> trip indicates that the drive is in keypad mode [<i>Reference Selector</i> (01.014) = 4 or 6 or M2 reference selector (21.003 = 4 or 6 if motor map 2 is selected)] and the keypad has been removed or disconnected from the drive.</p> <p><b>Recommended actions:</b></p> <ul style="list-style-type: none"> <li>• Re-install keypad and reset</li> <li>• Change <i>Reference Selector</i> (01.014) to select the reference from another source</li> </ul>						
<b>Line Sync</b>	<b>Synchronization to the power supply has been lost</b>						
39	<p>The <i>Line Sync</i> trip indicates that the inverter has lost the synchronization with the ac supply in Regen mode.</p> <p><b>Recommended actions:</b></p> <ul style="list-style-type: none"> <li>• Check the supply / supply connections to the regen drive</li> </ul>						
<b>Motor Too Hot</b>	<b>Output current overload timed out (<math>I^2t</math>)</b>						
20	<p>The <i>Motor Too Hot</i> trip indicates a motor thermal overload based on the rated current (Pr <b>05.007</b>) and motor thermal time constant (Pr <b>04.015</b>). Pr <b>04.019</b> displays the motor temperature as a percentage of the maximum value. The drive will trip on <i>Motor Too Hot</i> when Pr <b>04.019</b> gets to 100 %.</p> <p><b>Recommended actions:</b></p> <ul style="list-style-type: none"> <li>• Ensure the load is not jammed / sticking</li> <li>• Check the load on the motor has not changed</li> <li>• If seen during an auto-tune test in RFC-S mode, ensure the motor rated current in Pr <b>05.007</b> is <math>\leq</math> Heavy duty current rating of the drive</li> <li>• Tune the rated speed parameter (RFC-A mode only)</li> <li>• Check feedback signal for noise</li> <li>• Ensure the motor rated current is not zero</li> </ul>						

Trip	Diagnosis																				
<b>Name Plate</b>	<b>Electronic nameplate transfer has failed</b>																				
176	The <i>Name Plate</i> trip is initiated if an electronic name plate transfer between the drive and the motor has failed. The exact reason for the trip can be identified from the sub-trip number.																				
	<table border="1"> <thead> <tr> <th>Sub-trip</th> <th>Description</th> </tr> </thead> <tbody> <tr> <td>1</td> <td>Not enough memory space to complete the transfer</td> </tr> <tr> <td>2</td> <td>Communication with encoder failed</td> </tr> <tr> <td>3</td> <td>The transfer has failed</td> </tr> <tr> <td>4</td> <td>The checksum of the stored object has failed</td> </tr> </tbody> </table>	Sub-trip	Description	1	Not enough memory space to complete the transfer	2	Communication with encoder failed	3	The transfer has failed	4	The checksum of the stored object has failed										
	Sub-trip	Description																			
	1	Not enough memory space to complete the transfer																			
	2	Communication with encoder failed																			
3	The transfer has failed																				
4	The checksum of the stored object has failed																				
<b>Recommended actions:</b>																					
<ul style="list-style-type: none"> <li>• Ensure that the device encoder memory has at least 128 bytes to store the nameplate data</li> <li>• When writing the motor object (xx.000 = 11000), ensure that the device encoder memory has at least 256 bytes to store all the nameplate data.</li> <li>• When transferring between option module and encoder, ensure that the option slot has a feedback option module installed.</li> <li>• Check if the encoder has been initialized, <i>Position Feedback Initialized</i> (03.076).</li> <li>• Verify the encoder wiring.</li> </ul>																					
<b>Oht Brake</b>	<b>Braking IGBT over-temperature</b>																				
101	The <i>Oht Brake</i> over-temperature trip indicates that braking IGBT over-temperature has been detected based on software thermal model. <b>Recommended actions:</b> <ul style="list-style-type: none"> <li>• Check braking resistor value is greater than or equal to the minimum resistance value</li> </ul>																				
<b>Oht Control</b>	<b>Control stage over temperature</b>																				
23	This <i>Oht Control</i> trip indicates that a control stage over-temperature has been detected. From the sub-trip 'xyzz', the Thermistor location is identified by 'zz'.																				
	<table border="1"> <thead> <tr> <th>Source</th> <th>xx</th> <th>y</th> <th>zz</th> <th>Description</th> </tr> </thead> <tbody> <tr> <td>Control system</td> <td>00</td> <td>0</td> <td>01</td> <td>Control board thermistor 1 over temperature</td> </tr> <tr> <td>Control system</td> <td>00</td> <td>0</td> <td>02</td> <td>Control board thermistor 2 over temperature</td> </tr> <tr> <td>Control system</td> <td>00</td> <td>0</td> <td>03</td> <td>I/O board thermistor over temperature</td> </tr> </tbody> </table>	Source	xx	y	zz	Description	Control system	00	0	01	Control board thermistor 1 over temperature	Control system	00	0	02	Control board thermistor 2 over temperature	Control system	00	0	03	I/O board thermistor over temperature
	Source	xx	y	zz	Description																
	Control system	00	0	01	Control board thermistor 1 over temperature																
	Control system	00	0	02	Control board thermistor 2 over temperature																
Control system	00	0	03	I/O board thermistor over temperature																	
<b>Recommended actions:</b>																					
<ul style="list-style-type: none"> <li>• Check enclosure / drive fans are still functioning correctly</li> <li>• Check enclosure ventilation paths</li> <li>• Check enclosure door filters</li> <li>• Increase ventilation</li> <li>• Reduce the drive switching frequency</li> <li>• Check ambient temperature</li> </ul>																					

Trip	Diagnosis																				
<b>Oht dc bus</b>	<b>DC bus over temperature</b>																				
27	<p>The <i>Oht dc bus</i> trip indicates a DC bus component over temperature based on a software thermal model. The drive includes a thermal protection system to protect the DC bus components within the drive. This includes the effects of the output current and DC bus ripple. The estimated temperature is displayed as a percentage of the trip level in Pr <b>07.035</b>. If this parameter reaches 100 % then an <i>Oht dc bus</i> trip is initiated. The drive will attempt to stop the motor before tripping. If the motor does not stop in 10 seconds the drive trips immediately.</p> <table border="1"> <thead> <tr> <th>Source</th> <th>xx</th> <th>y</th> <th>zz</th> <th>Description</th> </tr> </thead> <tbody> <tr> <td>Control system</td> <td>00</td> <td>2</td> <td>00</td> <td>DC bus thermal model gives trip with sub-trip 0</td> </tr> </tbody> </table> <p>It is also possible in a multi-power module system for DC bus over-temperature to be detected from within the power stage. From this source the estimated temperature as a percentage of trip is not available and the trip is indicated as follows:</p> <table border="1"> <thead> <tr> <th>Source</th> <th>xx</th> <th>y</th> <th>zz</th> <th>Description</th> </tr> </thead> <tbody> <tr> <td>Control system</td> <td>01</td> <td>0</td> <td>00</td> <td>Power stage gives trip with sub-trip 0</td> </tr> </tbody> </table> <p><b>Recommended actions:</b></p> <ul style="list-style-type: none"> <li>• Check the AC supply voltage balance and levels</li> <li>• Check DC bus ripple level</li> <li>• Reduce duty cycle</li> <li>• Reduce motor load</li> <li>• Check the output current stability. If unstable; <ul style="list-style-type: none"> <li>• Check the motor map settings with motor nameplate (Pr <b>05.006</b>, Pr <b>05.007</b>, Pr <b>05.008</b>, Pr <b>05.009</b>, Pr <b>05.010</b>, Pr <b>05.011</b>) – (All Modes)</li> <li>• Disable slip compensation (Pr <b>05.027</b> = 0) – (Open loop)</li> <li>• Disable dynamic V to F operation (Pr <b>05.013</b> = 0) - (Open loop)</li> <li>• Select fixed boost (Pr <b>05.014</b> = Fixed) – (Open loop)</li> <li>• Select high stability space vector modulation (Pr <b>05.020</b> = 1) – (Open loop)</li> <li>• Disconnect the load and complete a rotating autotune (Pr <b>05.012</b>) – (RFC-A, RFC-S)</li> <li>• Auto-tune the rated speed value (Pr <b>05.016</b> = 1) – (RFC-A, RFC-S)</li> <li>• Reduce speed loop gains (Pr <b>03.010</b>, Pr <b>03.011</b>, Pr <b>03.012</b>) – (RFC-A, RFC-S)</li> <li>• Add a speed feedback filter value (Pr <b>03.042</b>) – (RFC-A, RFC-S)</li> <li>• Add a current demand filter (Pr <b>04.012</b>) – (RFC-A, RFC-S)</li> <li>• Check encoder signals for noise with an oscilloscope (RFC-A, RFC-S)</li> <li>• Check encoder mechanical coupling - (RFC-A, RFC-S)</li> </ul> </li> </ul>	Source	xx	y	zz	Description	Control system	00	2	00	DC bus thermal model gives trip with sub-trip 0	Source	xx	y	zz	Description	Control system	01	0	00	Power stage gives trip with sub-trip 0
	Source	xx	y	zz	Description																
Control system	00	2	00	DC bus thermal model gives trip with sub-trip 0																	
Source	xx	y	zz	Description																	
Control system	01	0	00	Power stage gives trip with sub-trip 0																	
<b>Oht Inverter</b>	<b>Inverter over temperature based on thermal model</b>																				
21	<p>This trip indicates that an IGBT junction over-temperature has been detected based on a firmware thermal model. The sub-trip indicates which model has initiated the trip in the form xxyzz as given below:</p> <table border="1"> <thead> <tr> <th>Source</th> <th>xx</th> <th>y</th> <th>zz</th> <th>Description</th> </tr> </thead> <tbody> <tr> <td>Control system</td> <td>00</td> <td>1</td> <td>00</td> <td>Inverter thermal model</td> </tr> <tr> <td>Control system</td> <td>00</td> <td>3</td> <td>00</td> <td>Braking IGBT thermal model</td> </tr> </tbody> </table> <p><b>Recommended actions with sub-trip 100:</b></p> <ul style="list-style-type: none"> <li>• Reduce the selected drive switching frequency</li> <li>• Ensure <i>Auto-switching Frequency Change Disable</i> (05.035) is set to Off</li> <li>• Reduce duty cycle</li> <li>• Increase acceleration / deceleration rates</li> <li>• Reduce motor load</li> <li>• Check DC bus ripple</li> <li>• Ensure all three input phases are present and balanced</li> </ul> <p><b>Recommended actions with sub-trip 300:</b></p> <ul style="list-style-type: none"> <li>• Reduce the braking load.</li> </ul>	Source	xx	y	zz	Description	Control system	00	1	00	Inverter thermal model	Control system	00	3	00	Braking IGBT thermal model					
	Source	xx	y	zz	Description																
Control system	00	1	00	Inverter thermal model																	
Control system	00	3	00	Braking IGBT thermal model																	

Trip	Diagnosis																																																		
<b>OHT Power</b>	<b>Power stage over temperature</b>																																																		
22	<p>This trip indicates that a power stage over-temperature has been detected. The sub-trip "xxyzz" indicates which thermistor is indicating the over-temperature. The thermistor numbering is different for a single module type drive (i.e. no parallel board fitted) and a multi-module type drive (i.e. parallel board fitted with one or more power modules) as shown below:</p> <p><b>Single module type drive:</b></p> <table border="1"> <thead> <tr> <th>Source</th> <th>xx</th> <th>y</th> <th>zz</th> <th>Description</th> </tr> </thead> <tbody> <tr> <td>Power system</td> <td>01</td> <td>0</td> <td>zz</td> <td>Thermistor location defined by zz in the power board</td> </tr> <tr> <td>Power system</td> <td>01</td> <td>Rectifier number</td> <td>zz</td> <td>Thermistor location defined by zz in the rectifier</td> </tr> </tbody> </table> <p><b>Multi-module type system:</b></p> <table border="1"> <thead> <tr> <th>Source</th> <th>xx</th> <th>y</th> <th>zz</th> <th>Description</th> </tr> </thead> <tbody> <tr> <td>Power system</td> <td>power module number</td> <td>0</td> <td>01</td> <td>U phase power device</td> </tr> <tr> <td>Power system</td> <td>power module number</td> <td>0</td> <td>02</td> <td>V phase power device</td> </tr> <tr> <td>Power system</td> <td>power module number</td> <td>0</td> <td>03</td> <td>W phase power device</td> </tr> <tr> <td>Power system</td> <td>power module number</td> <td>0</td> <td>04</td> <td>Rectifier</td> </tr> <tr> <td>Power system</td> <td>power module number</td> <td>0</td> <td>05</td> <td>General power system</td> </tr> <tr> <td>Power system</td> <td>power module number</td> <td>0</td> <td>00</td> <td>Braking IGBT</td> </tr> </tbody> </table> <p>Note that the power module that has caused the trip cannot be identified except for the braking IGBT temperature measurement</p> <p><b>Recommended actions:</b></p> <ul style="list-style-type: none"> <li>• Check enclosure / drive fans are still functioning correctly</li> <li>• Force the heatsink fans to run at maximum speed</li> <li>• Check enclosure ventilation paths</li> <li>• Check enclosure door filters</li> <li>• Increase ventilation</li> <li>• Reduce the drive switching frequency</li> <li>• Reduce duty cycle</li> <li>• Decrease acceleration / deceleration rates</li> <li>• Reduce motor load</li> <li>• Check the derating tables and confirm the drive is correctly sized for the application.</li> <li>• Use a drive with larger current / power rating</li> </ul>	Source	xx	y	zz	Description	Power system	01	0	zz	Thermistor location defined by zz in the power board	Power system	01	Rectifier number	zz	Thermistor location defined by zz in the rectifier	Source	xx	y	zz	Description	Power system	power module number	0	01	U phase power device	Power system	power module number	0	02	V phase power device	Power system	power module number	0	03	W phase power device	Power system	power module number	0	04	Rectifier	Power system	power module number	0	05	General power system	Power system	power module number	0	00	Braking IGBT
	Source	xx	y	zz	Description																																														
	Power system	01	0	zz	Thermistor location defined by zz in the power board																																														
	Power system	01	Rectifier number	zz	Thermistor location defined by zz in the rectifier																																														
	Source	xx	y	zz	Description																																														
	Power system	power module number	0	01	U phase power device																																														
	Power system	power module number	0	02	V phase power device																																														
	Power system	power module number	0	03	W phase power device																																														
	Power system	power module number	0	04	Rectifier																																														
	Power system	power module number	0	05	General power system																																														
Power system	power module number	0	00	Braking IGBT																																															
<b>OI ac</b>	<b>Instantaneous output over current detected</b>																																																		
3	<p>The instantaneous drive output current has exceeded VM_DRIVE_CURRENT_MAX. This trip cannot be reset until 10 s after the trip was initiated.</p> <table border="1"> <thead> <tr> <th>Source</th> <th>xx</th> <th>y</th> <th>zz</th> <th>Description</th> </tr> </thead> <tbody> <tr> <td>Control system</td> <td>00</td> <td>0</td> <td rowspan="2">00</td> <td rowspan="2">Instantaneous over-current trip when the measured a.c. current exceeds VM_DRIVE_CURRENT[MAX].</td> </tr> <tr> <td>Power system</td> <td>Power module number</td> <td>0</td> </tr> </tbody> </table> <p><b>Recommended actions:</b></p> <ul style="list-style-type: none"> <li>• Acceleration/deceleration rate is too short</li> <li>• If seen during auto-tune reduce the voltage boost</li> <li>• Check for short circuit on the output cabling</li> <li>• Check integrity of the motor insulation using an insulation tester</li> <li>• Check feedback device wiring</li> <li>• Check feedback device mechanical coupling</li> <li>• Check feedback signals are free from noise</li> <li>• Is motor cable length within limits for the frame size</li> <li>• Reduce the values in the speed loop gain parameters - (Pr 03.010, 03.011, 03.012) or (Pr 03.013, 03.014, 03.015)</li> <li>• Has the phase angle autotune been completed? (RFC-S mode only)</li> <li>• Reduce the values in current loop gain parameters (RFC-A, RFC-S modes only)</li> </ul>	Source	xx	y	zz	Description	Control system	00	0	00	Instantaneous over-current trip when the measured a.c. current exceeds VM_DRIVE_CURRENT[MAX].	Power system	Power module number	0																																					
	Source	xx	y	zz	Description																																														
Control system	00	0	00	Instantaneous over-current trip when the measured a.c. current exceeds VM_DRIVE_CURRENT[MAX].																																															
Power system	Power module number	0																																																	

Trip	Diagnosis												
<b>OI Brake</b>	<b>Braking IGBT over current detected: short circuit protection for the braking IGBT activated</b>												
4	The <i>OI Brake</i> trip indicates that over current has been detected in braking IGBT or braking IGBT protection has been activated. This trip cannot be reset until 10 s after the trip was initiated.												
	<table border="1"> <thead> <tr> <th>Source</th> <th>xx</th> <th>y</th> <th>zz</th> <th>Description</th> </tr> </thead> <tbody> <tr> <td>Power system</td> <td>Power module number</td> <td>0</td> <td>00</td> <td>Braking IGBT instantaneous over-current trip</td> </tr> </tbody> </table>	Source	xx	y	zz	Description	Power system	Power module number	0	00	Braking IGBT instantaneous over-current trip		
	Source	xx	y	zz	Description								
Power system	Power module number	0	00	Braking IGBT instantaneous over-current trip									
<p><b>Recommended actions:</b></p> <ul style="list-style-type: none"> <li>• Check brake resistor wiring</li> <li>• Check braking resistor value is greater than or equal to the minimum resistance value</li> <li>• Check braking resistor insulation</li> </ul>													
<b>OI dc</b>	<b>Power module over current detected from IGBT on state voltage monitoring</b>												
109	The <i>OI dc</i> trip indicates that the short circuit protection for the drive output stage has been activated. The table below shows where the trip has been detected..This trip cannot be reset until 10 s after the trip was initiated.												
	<table border="1"> <thead> <tr> <th>Source</th> <th>xx</th> <th>y</th> <th>zz</th> </tr> </thead> <tbody> <tr> <td>Control system</td> <td>00</td> <td>0</td> <td>00</td> </tr> <tr> <td>Power system</td> <td>Power module number</td> <td>0</td> <td>00</td> </tr> </tbody> </table>	Source	xx	y	zz	Control system	00	0	00	Power system	Power module number	0	00
	Source	xx	y	zz									
Control system	00	0	00										
Power system	Power module number	0	00										
<p><b>Recommended actions:</b></p> <ul style="list-style-type: none"> <li>• Disconnect the motor cable at the drive end and check the motor and cable insulation with an insulation tester</li> <li>• Replace the drive</li> </ul>													
<b>OI Snubber</b>	<b>Snubber over-current detected</b>												
92	The <i>OI Snubber</i> trip indicates that an over-current condition has been detected in the rectifier snubber circuit. The reason for the trip can be identified by the sub-trip number.												
	<table border="1"> <thead> <tr> <th>Source</th> <th>xx</th> <th>y</th> <th>zz</th> <th>Description</th> </tr> </thead> <tbody> <tr> <td>Power system</td> <td>01</td> <td>Rectifier number*</td> <td>00</td> <td>Rectifier snubber over-current trip detected.</td> </tr> </tbody> </table>	Source	xx	y	zz	Description	Power system	01	Rectifier number*	00	Rectifier snubber over-current trip detected.		
	Source	xx	y	zz	Description								
Power system	01	Rectifier number*	00	Rectifier snubber over-current trip detected.									
<p>* For a parallel power-module system the rectifier number will be one as it is not possible to determine which rectifier has detected the fault.</p> <p><b>Recommended actions:</b></p> <ul style="list-style-type: none"> <li>• Ensure the internal EMC Filter is installed</li> <li>• Ensure the motor cable length does not exceed the maximum for selected switching frequency</li> <li>• Check for supply voltage imbalance</li> <li>• Check for supply disturbance such as notching from a DC drive</li> <li>• Check the motor and motor cable insulation with an insulation tester</li> <li>• Fit an output line reactor or sinusoidal filter</li> </ul>													
<b>Option Disable</b>	<b>Option module does not acknowledge during drive mode changeover</b>												
215	<p>During drive mode changeover option modules must acknowledge that they have stopped accessing the communications system between the option slots and the drive. If an option module does not do this in the allowed time then this trip is produced.</p> <p><b>Recommended trip:</b></p> <ul style="list-style-type: none"> <li>• Reset the trip</li> <li>• If the trip persists replace the option module</li> </ul>												

Trip	Diagnosis																											
<b>Out Phase Loss</b>	<b>Output phase loss detected</b>																											
98	<p>The <i>Out Phase Loss</i> trip indicates that a phase loss has been detected at the drive output.</p> <p>Note that if Reverse Output Phase Sequence (05.042) = 1 the physical output phases are reversed, and so sub-trip 3 refers to physical output phase V and sub-trip 2 refers to physical output phase W.</p> <table border="1"> <thead> <tr> <th>Sub-trip</th> <th>Reason</th> </tr> </thead> <tbody> <tr> <td>1</td> <td>U phase detected as disconnected when drive enabled to run</td> </tr> <tr> <td>2</td> <td>V phase detected as disconnected when drive enabled to run</td> </tr> <tr> <td>3</td> <td>W phase detected as disconnected when drive enabled to run</td> </tr> <tr> <td>4</td> <td>Output phase loss detected when the drive is running</td> </tr> </tbody> </table> <p><b>Recommended action:</b></p> <ul style="list-style-type: none"> <li>• Check motor and drive connections</li> <li>• To disable the trip set <i>Output Phase Loss Detection Enable</i> (06.059) = 0</li> </ul>	Sub-trip	Reason	1	U phase detected as disconnected when drive enabled to run	2	V phase detected as disconnected when drive enabled to run	3	W phase detected as disconnected when drive enabled to run	4	Output phase loss detected when the drive is running																	
	Sub-trip	Reason																										
	1	U phase detected as disconnected when drive enabled to run																										
	2	V phase detected as disconnected when drive enabled to run																										
	3	W phase detected as disconnected when drive enabled to run																										
4	Output phase loss detected when the drive is running																											
<b>Over Speed</b>	<b>Motor speed has exceeded the over speed threshold</b>																											
7	<p>In open loop mode, if the <i>Output Frequency</i> (05.001) exceeds the threshold set in <i>Over Speed Threshold</i> (03.008) in either direction an Over Speed trip is produced. In RFC-A and RFC-S mode, if the Speed Feedback (03.002) exceeds the Over Speed Threshold in Pr <b>03.008</b> in either direction an Over Speed trip is produced. If Pr <b>03.008</b> is set to 0.0 the threshold is then equal to 1.2 x the value set in Pr <b>01.006</b>.</p> <p>In RFC-A and RFC-S modes if an SSI encoder is being used and P1 SSI Incremental Mode (03.047) is set to Off, an Over Speed trip will be produced when the encoder passes through the boundary between its maximum position and zero.</p> <p>The above description relates to a standard over speed trip, however in RFC-S mode it is possible to produce an Overspeed trip with sub-trip 1. This is caused if the speed is allowed to exceed the safe level in RFC-S mode with flux weakening. See Enable High Speed Mode (05.022) for details.</p> <p><b>Recommended actions:</b></p> <ul style="list-style-type: none"> <li>• Check the motor is not being driven by another part of the system</li> <li>• Reduce the <i>Speed Controller Proportional Gain</i> (03.010) to reduce the speed overshoot (RFC-A, RFC-S modes only)</li> <li>• If an SSI encoder is being used set Pr <b>03.047</b> to 1</li> </ul> <p>The above description relates to a standard Over Speed trip, however in RFC-S mode it is possible to produce an <i>Over Speed.1</i> trip. This is caused if the speed is allowed to exceed the safe level in RFC-S mode with flux weakening when <i>Enable High Speed Mode</i> (05.022) is set to -1.</p>																											
	<b>Over Volts</b>	<b>DC bus voltage has exceeded the peak level or maximum continuous level for 15 seconds</b>																										
2	<p>The <i>Over Volts</i> trip indicates that the DC bus voltage has exceeded the VM_DC_VOLTAGE[MAX] or VM_DC_VOLTAGE_SET[MAX] for 15 s. The trip threshold varies depending on voltage rating of the drive as shown below.</p> <table border="1"> <thead> <tr> <th>Voltage rating</th> <th>VM_DC_VOLTAGE[MAX]</th> <th>VM_DC_VOLTAGE_SET[MAX]</th> </tr> </thead> <tbody> <tr> <td>200</td> <td>415</td> <td>410</td> </tr> <tr> <td>400</td> <td>830</td> <td>815</td> </tr> <tr> <td>575</td> <td>990</td> <td>970</td> </tr> <tr> <td>690</td> <td>1190</td> <td>1175</td> </tr> </tbody> </table> <p><b>Sub-trip Identification</b></p> <table border="1"> <thead> <tr> <th>Source</th> <th>xx</th> <th>y</th> <th>zz</th> </tr> </thead> <tbody> <tr> <td>Control system</td> <td>00</td> <td>0</td> <td>01: Instantaneous trip when the DC bus voltage exceeds VM_DC_VOLTAGE[MAX].</td> </tr> <tr> <td>Control system</td> <td>00</td> <td>0</td> <td>02: Time delayed trip indicating that the DC bus voltage is above VM_DC_VOLTAGE_SET[MAX].</td> </tr> </tbody> </table> <p><b>Recommended actions:</b></p> <ul style="list-style-type: none"> <li>• Increase deceleration ramp (Pr <b>00.004</b>)</li> <li>• Decrease the braking resistor value (staying above the minimum value)</li> <li>• Check nominal AC supply level</li> <li>• Check for supply disturbances which could cause the DC bus to rise</li> <li>• Check motor insulation using an insulation tester</li> </ul>	Voltage rating	VM_DC_VOLTAGE[MAX]	VM_DC_VOLTAGE_SET[MAX]	200	415	410	400	830	815	575	990	970	690	1190	1175	Source	xx	y	zz	Control system	00	0	01: Instantaneous trip when the DC bus voltage exceeds VM_DC_VOLTAGE[MAX].	Control system	00	0	02: Time delayed trip indicating that the DC bus voltage is above VM_DC_VOLTAGE_SET[MAX].
	Voltage rating	VM_DC_VOLTAGE[MAX]	VM_DC_VOLTAGE_SET[MAX]																									
	200	415	410																									
	400	830	815																									
	575	990	970																									
690	1190	1175																										
Source	xx	y	zz																									
Control system	00	0	01: Instantaneous trip when the DC bus voltage exceeds VM_DC_VOLTAGE[MAX].																									
Control system	00	0	02: Time delayed trip indicating that the DC bus voltage is above VM_DC_VOLTAGE_SET[MAX].																									

Trip	Diagnosis												
<b>Phase Loss</b>	<b>Supply phase loss</b>												
32	<p>This trip indicates that the drive has detected an input phase loss or large supply imbalance. Phase loss can be detected directly from the supply where the drive has a thyristor base charge system (Frame size 7 and above). If phase loss is detected using this method the drive trips immediately and the xx part of the sub-trip is set to 01. In all sizes of drive phase loss is also detected by monitoring the ripple in the DC bus voltage in which case the drive attempts to stop the drive before tripping unless bit 2 of <i>Action On Trip Detection</i> (10.037) is set to one. When phase loss is detected by monitoring the ripple in the DC bus voltage the xx part of the sub-trip is zero.</p> <table border="1"> <thead> <tr> <th>Source</th> <th>xx</th> <th>y</th> <th>zz</th> </tr> </thead> <tbody> <tr> <td>Control system</td> <td>00</td> <td>0</td> <td>00: Phase loss detected from DC bus ripple</td> </tr> <tr> <td>Power system (1)</td> <td>Power module number</td> <td>Rectifier number (2)</td> <td>00: Phase loss detected directly from the supply</td> </tr> </tbody> </table> <p>(1) Input phase loss detection can be disabled when the drive required to operate from the DC supply or from a single phase supply in <i>Input Phase Loss Detection Mode</i> (06.047).</p> <p>(2) For a parallel power-module system the rectifier number will be one as it is not possible to determine which rectifier has detected the fault.</p> <p>This trip does not occur in regen mode.</p> <p><b>Recommended actions:</b></p> <ul style="list-style-type: none"> <li>• Check the AC supply voltage balance and level at full load</li> <li>• Check the DC bus ripple level with an isolated oscilloscope</li> <li>• Check the output current stability</li> <li>• Reduce the duty cycle</li> <li>• Reduce the motor load</li> <li>• Disable the phase loss detection, set Pr <b>06.047</b> to 2.</li> <li>• Check for mechanical resonance with the load</li> </ul>	Source	xx	y	zz	Control system	00	0	00: Phase loss detected from DC bus ripple	Power system (1)	Power module number	Rectifier number (2)	00: Phase loss detected directly from the supply
	Source	xx	y	zz									
Control system	00	0	00: Phase loss detected from DC bus ripple										
Power system (1)	Power module number	Rectifier number (2)	00: Phase loss detected directly from the supply										
<b>Phasing error</b>	<b>This indicates that the phase offset angle is incorrect</b>												
198	<p>This indicates that the phase offset angle in <i>Position Feedback Phase Angle</i> (03.025) (or <i>M2 Position Feedback Phase Angle</i> (21.020) if the second motor map is being used) is incorrect if position feedback is being used and the drive is unable to control the motor correctly.</p> <p><b>Recommended actions:</b></p> <ul style="list-style-type: none"> <li>• Check the encoder wiring.</li> <li>• Check the encoder signals for noise with an oscilloscope.</li> <li>• Check encoder mechanical coupling.</li> <li>• Perform an auto-tune to measure the encoder phase angle or manually enter the correct phase angle into <i>Position Feedback Phase Angle</i> (03.025).</li> <li>• Spurious Phasing Error trips can sometimes be seen in very dynamic applications. This trip can be disabled by setting <i>Over Speed Threshold</i> (03.008) to a value greater than zero.</li> </ul> <p>If sensorless control is being used this indicates that significant instability has occurred and the motor has accelerated without control.</p> <p><b>Recommended actions:</b></p> <ul style="list-style-type: none"> <li>• Ensure that the motor parameters are set-up correctly.</li> <li>• Reduce the speed controller gains.</li> </ul>												
<b>Power Comms</b>	<b>A Power Comms trip indicates a communications problem within the power system of the drive</b>												
90	<p>A Power Comms trip indicates a communications problem within the power system of the drive. The reason for the trip can be identified by the sub-trip number.</p> <table border="1"> <thead> <tr> <th>Type of drive</th> <th>xx</th> <th>y</th> <th>zz</th> </tr> </thead> <tbody> <tr> <td>Control system</td> <td>Power module number</td> <td>Rectifier number*</td> <td>00: Excessive communications errors detected by the rectifier module</td> </tr> </tbody> </table> <p>* For a parallel power-module system the rectifier number will be one as it is not possible to determine which rectifier has detected the fault.</p> <p><b>Recommended actions:</b></p> <ul style="list-style-type: none"> <li>• Hardware fault – Contact the supplier of the drive</li> </ul>	Type of drive	xx	y	zz	Control system	Power module number	Rectifier number*	00: Excessive communications errors detected by the rectifier module				
	Type of drive	xx	y	zz									
Control system	Power module number	Rectifier number*	00: Excessive communications errors detected by the rectifier module										

Trip	Diagnosis																																													
<b>Power Data</b>	<b>Power system configuration data error</b>																																													
220	The <i>Power Data</i> trip indicates that there is an error in the configuration data stored in the power system.																																													
	<table border="1"> <thead> <tr> <th>Source</th> <th>xx</th> <th>y</th> <th>zz</th> <th>Description</th> </tr> </thead> <tbody> <tr> <td>Control system</td> <td>00</td> <td>0</td> <td>02</td> <td>There is no data table to be uploaded to the control board</td> </tr> <tr> <td>Control system</td> <td>00</td> <td>0</td> <td>03</td> <td>The power system data table is bigger than the space available in the control pod to store it.</td> </tr> <tr> <td>Control system</td> <td>00</td> <td>0</td> <td>04</td> <td>The size of the table given in the table is incorrect.</td> </tr> <tr> <td>Control system</td> <td>00</td> <td>0</td> <td>05</td> <td>Table CRC error.</td> </tr> <tr> <td>Control system</td> <td>00</td> <td>0</td> <td>06</td> <td>The version number of the generator software that produced the table is too low. i.e. a table from a newer generator is required that includes features that have been added to the table that may not be present.</td> </tr> <tr> <td>Power system</td> <td>Power module number</td> <td>0</td> <td>00</td> <td>The power data table used internally by the power module has an error. (For a multi-power module drive this indicates any error with the code tables in the power system).</td> </tr> <tr> <td>Power system</td> <td>Power module number</td> <td>0</td> <td>01</td> <td>The power data table that is uploaded to the control system on power up has an error.</td> </tr> <tr> <td>Power system</td> <td>Power module number</td> <td>0</td> <td>02</td> <td>The power data table used internally by the power module does not match the hardware identification of the power module.</td> </tr> </tbody> </table>	Source	xx	y	zz	Description	Control system	00	0	02	There is no data table to be uploaded to the control board	Control system	00	0	03	The power system data table is bigger than the space available in the control pod to store it.	Control system	00	0	04	The size of the table given in the table is incorrect.	Control system	00	0	05	Table CRC error.	Control system	00	0	06	The version number of the generator software that produced the table is too low. i.e. a table from a newer generator is required that includes features that have been added to the table that may not be present.	Power system	Power module number	0	00	The power data table used internally by the power module has an error. (For a multi-power module drive this indicates any error with the code tables in the power system).	Power system	Power module number	0	01	The power data table that is uploaded to the control system on power up has an error.	Power system	Power module number	0	02	The power data table used internally by the power module does not match the hardware identification of the power module.
	Source	xx	y	zz	Description																																									
	Control system	00	0	02	There is no data table to be uploaded to the control board																																									
	Control system	00	0	03	The power system data table is bigger than the space available in the control pod to store it.																																									
	Control system	00	0	04	The size of the table given in the table is incorrect.																																									
	Control system	00	0	05	Table CRC error.																																									
	Control system	00	0	06	The version number of the generator software that produced the table is too low. i.e. a table from a newer generator is required that includes features that have been added to the table that may not be present.																																									
	Power system	Power module number	0	00	The power data table used internally by the power module has an error. (For a multi-power module drive this indicates any error with the code tables in the power system).																																									
	Power system	Power module number	0	01	The power data table that is uploaded to the control system on power up has an error.																																									
Power system	Power module number	0	02	The power data table used internally by the power module does not match the hardware identification of the power module.																																										
<b>Recommended actions:</b>																																														
<ul style="list-style-type: none"> <li>Hardware fault – Contact the supplier of the drive</li> </ul>																																														
<b>Power Down Save</b>	<b>Power down save error</b>																																													
37	The <i>Power Down Save</i> trip indicates that an error has been detected in the power down save parameters saved in non-volatile memory.																																													
	<b>Recommended actions:</b>																																													
	<ul style="list-style-type: none"> <li>Perform a 1001 save in Pr <b>mm.000</b> to ensure that the trip doesn't occur the next time the drive is powered up.</li> </ul>																																													
<b>PSU</b>	<b>Internal power supply fault</b>																																													
5	The <i>PSU</i> trip indicates that one or more internal power supply rails are outside limits or overloaded.																																													
	<table border="1"> <thead> <tr> <th>Source</th> <th>xx</th> <th>y</th> <th>Description</th> </tr> </thead> <tbody> <tr> <td>Control system</td> <td>00</td> <td>0</td> <td>Internal power supply overload</td> </tr> <tr> <td>Power system</td> <td>Power module number</td> <td>Rectifier number*</td> <td>Rectifier internal power supply overload</td> </tr> </tbody> </table>	Source	xx	y	Description	Control system	00	0	Internal power supply overload	Power system	Power module number	Rectifier number*	Rectifier internal power supply overload																																	
	Source	xx	y	Description																																										
Control system	00	0	Internal power supply overload																																											
Power system	Power module number	Rectifier number*	Rectifier internal power supply overload																																											
*For a parallel power-module system the rectifier number will be zero as it is not possible to determine which rectifier has detected the fault.																																														
	<b>Recommended actions:</b>																																													
	<ul style="list-style-type: none"> <li>Remove any option modules and perform a reset</li> <li>Remove encoder connection and perform a reset</li> <li>Hardware fault within the drive – return the drive to the supplier</li> </ul>																																													
<b>PSU 24V</b>	<b>24V internal power supply overload</b>																																													
9	The total user load of the drive and option modules has exceeded the internal 24 V power supply limit. The user load consists of the drive digital outputs and main encoder supply.																																													
	<b>Recommended actions:</b>																																													
	<ul style="list-style-type: none"> <li>Reduce the load and reset</li> <li>Provide an external 24 V power supply on control terminal 2</li> <li>Remove all option modules</li> </ul>																																													

Trip	Diagnosis								
<b>Rating Mismatch</b>	<b>Power stage recognition: Multi module voltage or current rating mismatch</b>								
223	<p>The <i>Rating Mismatch</i> trip indicates that there is a voltage rating or current rating mismatch in a multi-module drive system. This trip is only applicable to modular drives that are connected in parallel. A mixture of power modules with different voltage or current ratings within the same multi-module drive system is not allowed and will cause a Rating Mismatch trip.</p> <p><b>Recommended action:</b></p> <ul style="list-style-type: none"> <li>• Ensure that all modules in a multi-modular drive system are of the same frame size and rating (voltage and current)</li> <li>• Hardware fault – Contact the supplier of the drive</li> </ul>								
<b>Rectifier Set-up</b>	<b>A rectifier has not been set-up correctly in a multi-power module system.</b>								
94	<p>A rectifier has not been set-up correctly in a multi-power module system.</p> <p>Recommended action:</p> <ul style="list-style-type: none"> <li>• Check the inter-power module wiring</li> </ul>								
<b>Reserved</b>	<b>Reserved trips</b>								
01 95 102 104 - 108 161-168 170-173 222 228-246	<p>These trip numbers are reserved trip numbers for future use. These trips should not be used by the user application programs.</p>								
<b>Resistance</b>	<b>Measured resistance has exceeded the parameter range</b>								
33	<p>This trip indicates that either the value being used for motor stator resistance is too high or that an attempt to do a test involving measuring motor stator resistance has failed. The maximum for the stator resistance parameters is generally higher than the maximum value that can be used in the control algorithms. If the value exceeds <math>(VFS / \sqrt{2}) / Full\ Scale\ Current\ Kc</math> (11.061), where VFS is the full scale DC bus voltage then this trip is initiated. If the value is the result of a measurement made by the drive then sub-trip 1 is applied, or if it is because the parameter has been changed by the user then sub-trip 3 is applied. During the stator resistance section of auto-tuning an additional test is performed to measure the drive inverter characteristics to provide the compensation necessary for dead-times. If the inverter characteristic measurement fails then sub-trip 2 is applied.</p> <table border="1"> <thead> <tr> <th>Sub-trip</th> <th>Reason</th> </tr> </thead> <tbody> <tr> <td>1</td> <td>Measured stator resistance exceeded the allowed range</td> </tr> <tr> <td>2</td> <td>It was not possible to measure the inverter characteristic</td> </tr> <tr> <td>3</td> <td>The stator resistance associated with the presently selected motor map exceeds the allowed range</td> </tr> </tbody> </table> <p><b>Recommended actions:</b></p> <ul style="list-style-type: none"> <li>• Check that the value that has been entered in the stator resistance does not exceed the allowed range (for the presently selected motor map)</li> <li>• Check the motor cable / connections</li> <li>• Check the integrity of the motor stator winding using an insulation tester</li> <li>• Check the motor phase to phase resistance at the drive terminals</li> <li>• Check the motor phase to phase resistance at the motor terminals</li> <li>• Ensure the stator resistance of the motor falls within the range of the drive model</li> <li>• Select fixed boost mode (Pr <b>05.014</b> = Fixed) and verify the output current waveforms with an oscilloscope</li> <li>• Replace the motor</li> </ul>	Sub-trip	Reason	1	Measured stator resistance exceeded the allowed range	2	It was not possible to measure the inverter characteristic	3	The stator resistance associated with the presently selected motor map exceeds the allowed range
Sub-trip	Reason								
1	Measured stator resistance exceeded the allowed range								
2	It was not possible to measure the inverter characteristic								
3	The stator resistance associated with the presently selected motor map exceeds the allowed range								
<b>Slot App Menu</b>	<b>Application menu Customization conflict error</b>								
216	<p>The Slot App Menu trip indicates that more than one option slot has requested to customize the application menus 18, 19 and 20. The sub-trip number indicates which option slot has been allowed to customize the menus.</p> <p><b>Recommended actions:</b></p> <ul style="list-style-type: none"> <li>• Ensure that only one of the Application modules is configured to customize the application menus 18, 19 and 20</li> </ul>								

Trip	Diagnosis																						
<b>SlotX Different</b>	<b>Option module in option slot X has changed</b>																						
204 209 214	The <i>SlotX Different</i> trip indicates that the option module in option slot X on the drive is a different type to that installed when parameters were last saved on the drive. The reason for the trip can be identified by the sub-trip number.																						
	<table border="1"> <thead> <tr> <th>Sub-trip</th> <th>Reason</th> </tr> </thead> <tbody> <tr> <td>1</td> <td>No module was installed previously</td> </tr> <tr> <td>2</td> <td>A module with the same identifier is installed, but the set-up menu for this option slot has been changed, and so default parameters have been loaded for this menu.</td> </tr> <tr> <td>3</td> <td>A module with the same identifier is installed, but the applications menu for this option slot has been changed, and so default parameters have been loaded for this menu.</td> </tr> <tr> <td>4</td> <td>A module with the same identifier is installed, but the set-up and applications menu for this option slot have been changed, and so default parameters have been loaded for these menus.</td> </tr> <tr> <td>&gt;99</td> <td>Shows the identifier of the module previously installed.</td> </tr> </tbody> </table>	Sub-trip	Reason	1	No module was installed previously	2	A module with the same identifier is installed, but the set-up menu for this option slot has been changed, and so default parameters have been loaded for this menu.	3	A module with the same identifier is installed, but the applications menu for this option slot has been changed, and so default parameters have been loaded for this menu.	4	A module with the same identifier is installed, but the set-up and applications menu for this option slot have been changed, and so default parameters have been loaded for these menus.	>99	Shows the identifier of the module previously installed.										
	Sub-trip	Reason																					
	1	No module was installed previously																					
	2	A module with the same identifier is installed, but the set-up menu for this option slot has been changed, and so default parameters have been loaded for this menu.																					
	3	A module with the same identifier is installed, but the applications menu for this option slot has been changed, and so default parameters have been loaded for this menu.																					
4	A module with the same identifier is installed, but the set-up and applications menu for this option slot have been changed, and so default parameters have been loaded for these menus.																						
>99	Shows the identifier of the module previously installed.																						
<b>Recommended actions:</b>																							
<ul style="list-style-type: none"> <li>Turn off the power, ensure the correct option modules are installed in the correct option slots and re-apply the power.</li> <li>Confirm that the currently installed option module is correct, ensure option module parameters are set correctly and perform a user save in Pr <b>mm.000</b>.</li> </ul>																							
<b>SlotX Error</b>	<b>Option module in option slot X has detected a fault</b>																						
202 207 212	The <i>SlotX Error</i> trip indicates that the option module in option slot X on the drive has detected an error. The reason for the error can be identified by the sub-trip number.																						
<b>Recommended actions:</b>																							
<ul style="list-style-type: none"> <li>See relevant <i>Option Module User Guide</i> for details of the trip</li> </ul>																							
<b>SlotX HF</b>	<b>Option module X hardware fault</b>																						
200 205 210	The <i>SlotX HF</i> trip indicates that the option module in option slot X on the drive has indicated a hardware fault. The possible causes of the trip can be identified by the sub-trip number.																						
	<table border="1"> <thead> <tr> <th>Sub-trip</th> <th>Reason</th> </tr> </thead> <tbody> <tr> <td>1</td> <td>The module category cannot be identified</td> </tr> <tr> <td>2</td> <td>All the required customized menu table information has not been supplied or the tables supplied are corrupt</td> </tr> <tr> <td>3</td> <td>There is insufficient memory available to allocate the comms buffers for this module</td> </tr> <tr> <td>4</td> <td>The module has not indicated that it is running correctly during drive power-up</td> </tr> <tr> <td>5</td> <td>Module has been removed after power-up or it has stopped working</td> </tr> <tr> <td>6</td> <td>The module has not indicated that it has stopped accessing drive parameters during a drive mode change</td> </tr> <tr> <td>7</td> <td>The module has failed to acknowledge that a request has been made to reset the drive processor</td> </tr> <tr> <td>8</td> <td>The drive failed to correctly read the menu table from the module during drive power up</td> </tr> <tr> <td>9</td> <td>The drive failed to upload menu tables from the module and timed out (5 s)</td> </tr> <tr> <td>10</td> <td>Menu table CRC invalid</td> </tr> </tbody> </table>	Sub-trip	Reason	1	The module category cannot be identified	2	All the required customized menu table information has not been supplied or the tables supplied are corrupt	3	There is insufficient memory available to allocate the comms buffers for this module	4	The module has not indicated that it is running correctly during drive power-up	5	Module has been removed after power-up or it has stopped working	6	The module has not indicated that it has stopped accessing drive parameters during a drive mode change	7	The module has failed to acknowledge that a request has been made to reset the drive processor	8	The drive failed to correctly read the menu table from the module during drive power up	9	The drive failed to upload menu tables from the module and timed out (5 s)	10	Menu table CRC invalid
	Sub-trip	Reason																					
	1	The module category cannot be identified																					
	2	All the required customized menu table information has not been supplied or the tables supplied are corrupt																					
	3	There is insufficient memory available to allocate the comms buffers for this module																					
	4	The module has not indicated that it is running correctly during drive power-up																					
	5	Module has been removed after power-up or it has stopped working																					
	6	The module has not indicated that it has stopped accessing drive parameters during a drive mode change																					
	7	The module has failed to acknowledge that a request has been made to reset the drive processor																					
	8	The drive failed to correctly read the menu table from the module during drive power up																					
9	The drive failed to upload menu tables from the module and timed out (5 s)																						
10	Menu table CRC invalid																						
<b>Recommended actions:</b>																							
<ul style="list-style-type: none"> <li>Ensure the option module is installed correctly</li> <li>Replace the option module</li> <li>Replace the drive</li> </ul>																							
<b>SlotX Not Fitted</b>	<b>Option module in option slot X has been removed</b>																						
203 208 213	The <i>SlotX Not Fitted</i> trip indicates that the option module in option slot X on the drive has been removed since the last power up.																						
<b>Recommended actions:</b>																							
<ul style="list-style-type: none"> <li>Ensure the option module is installed correctly.</li> <li>Re-install the option module.</li> <li>To confirm that the removed option module is no longer required perform a save function in Pr <b>mm.000</b>.</li> </ul>																							
<b>SlotX Watchdog</b>	<b>Option module watchdog function service error</b>																						
201 206 211	The <i>SlotX Watchdog</i> trip indicates that the option module installed in Slot X has started the option watchdog function and then failed to service the watchdog correctly.																						
<b>Recommended actions:</b>																							
<ul style="list-style-type: none"> <li>Replace the option module</li> </ul>																							

Trip	Diagnosis																																																		
<b>Soft Start</b>	<b>Soft start relay failed to close, soft start monitor failed</b>																																																		
226	<p>The <i>Soft Start</i> trip indicates that the soft start relay in the drive failed to close or the soft start monitoring circuit has failed.</p> <p><b>Recommended actions:</b></p> <ul style="list-style-type: none"> <li>Hardware fault – Contact the supplier of the drive</li> </ul>																																																		
<b>Stored HF</b>	<b>Hardware trip has occurred during last power down</b>																																																		
221	<p>The <i>Stored HF</i> trip indicates that a hardware trip (HF01 –HF19) has occurred and the drive has been power cycled. The sub-trip number identifies the HF trip i.e. stored HF.17.</p> <p><b>Recommended actions:</b></p> <ul style="list-style-type: none"> <li>Enter 1299 in Pr <b>mm.000</b> and press reset to clear the trip</li> </ul>																																																		
<b>Sub-array RAM</b>	<b>RAM allocation error</b>																																																		
227	<p>The <i>Sub-array RAM</i> trip indicates that an option module, derivative image or user program image has requested more parameter RAM than is allowed. The RAM allocation is checked in order of resulting sub-trip numbers, and so the failure with the highest sub-trip number is given. The sub-trip is calculated as (parameter size) + (parameter type) + sub-array number.</p> <table border="1" style="display: inline-table; margin-right: 20px;"> <thead> <tr> <th>Parameter size</th> <th>Value</th> </tr> </thead> <tbody> <tr><td>1 bit</td><td>1000</td></tr> <tr><td>8 bit</td><td>2000</td></tr> <tr><td>16 bit</td><td>3000</td></tr> <tr><td>32 bit</td><td>4000</td></tr> <tr><td>64 bit</td><td>5000</td></tr> </tbody> </table> <table border="1" style="display: inline-table;"> <thead> <tr> <th>Parameter type</th> <th>Value</th> </tr> </thead> <tbody> <tr><td>Volatile</td><td>0</td></tr> <tr><td>User save</td><td>100</td></tr> <tr><td>Power-down save</td><td>200</td></tr> </tbody> </table> <table border="1"> <thead> <tr> <th>Sub-array</th> <th>Menus</th> <th>Value</th> </tr> </thead> <tbody> <tr><td>Applications menu</td><td>18-20</td><td>1</td></tr> <tr><td>Derivative image</td><td>29</td><td>2</td></tr> <tr><td>User program image</td><td>30</td><td>3</td></tr> <tr><td>Option slot 1 set-up</td><td>15</td><td>4</td></tr> <tr><td>Option slot 1 applications</td><td>25</td><td>5</td></tr> <tr><td>Option slot 2 set-up</td><td>16</td><td>6</td></tr> <tr><td>Option slot 2 applications</td><td>26</td><td>7</td></tr> <tr><td>Option slot 3 set-up</td><td>17</td><td>8</td></tr> <tr><td>Option slot 3 applications</td><td>27</td><td>9</td></tr> </tbody> </table>	Parameter size	Value	1 bit	1000	8 bit	2000	16 bit	3000	32 bit	4000	64 bit	5000	Parameter type	Value	Volatile	0	User save	100	Power-down save	200	Sub-array	Menus	Value	Applications menu	18-20	1	Derivative image	29	2	User program image	30	3	Option slot 1 set-up	15	4	Option slot 1 applications	25	5	Option slot 2 set-up	16	6	Option slot 2 applications	26	7	Option slot 3 set-up	17	8	Option slot 3 applications	27	9
Parameter size	Value																																																		
1 bit	1000																																																		
8 bit	2000																																																		
16 bit	3000																																																		
32 bit	4000																																																		
64 bit	5000																																																		
Parameter type	Value																																																		
Volatile	0																																																		
User save	100																																																		
Power-down save	200																																																		
Sub-array	Menus	Value																																																	
Applications menu	18-20	1																																																	
Derivative image	29	2																																																	
User program image	30	3																																																	
Option slot 1 set-up	15	4																																																	
Option slot 1 applications	25	5																																																	
Option slot 2 set-up	16	6																																																	
Option slot 2 applications	26	7																																																	
Option slot 3 set-up	17	8																																																	
Option slot 3 applications	27	9																																																	
<b>Temp Feedback</b>	<b>Internal thermistor has failed</b>																																																		
218	<p>The <i>Temp Feedback</i> trip indicates that an internal thermistor has failed. The thermistor location can be identified by the sub-trip number.</p> <table border="1"> <thead> <tr> <th>Source</th> <th>xx</th> <th>y</th> <th>zz</th> </tr> </thead> <tbody> <tr> <td>Control board</td> <td>00</td> <td>00</td> <td>01: Control board thermistor 1 02: Control board thermistor 2 03: I/O board thermistor</td> </tr> <tr> <td>Power system</td> <td>Power module number</td> <td>0</td> <td>Zero for temperature feedback provided via power system comms.21, 22 and 23 for direct ELV temperature feedback.</td> </tr> <tr> <td>Power system</td> <td>Power module number</td> <td>Rectifier number*</td> <td>Always zero</td> </tr> </tbody> </table> <p>* For a parallel power-module system the rectifier number will be one as it is not possible to determine which rectifier has detected the fault.</p> <p><b>Recommended actions:</b></p> <ul style="list-style-type: none"> <li>Hardware fault – Contact the supplier of the drive</li> </ul>	Source	xx	y	zz	Control board	00	00	01: Control board thermistor 1 02: Control board thermistor 2 03: I/O board thermistor	Power system	Power module number	0	Zero for temperature feedback provided via power system comms.21, 22 and 23 for direct ELV temperature feedback.	Power system	Power module number	Rectifier number*	Always zero																																		
Source	xx	y	zz																																																
Control board	00	00	01: Control board thermistor 1 02: Control board thermistor 2 03: I/O board thermistor																																																
Power system	Power module number	0	Zero for temperature feedback provided via power system comms.21, 22 and 23 for direct ELV temperature feedback.																																																
Power system	Power module number	Rectifier number*	Always zero																																																
<b>Th Brake Res</b>	<b>Brake resistor over temperature</b>																																																		
10	<p>The <i>Th Brake Res</i> is initiated, If hardware based braking resistor thermal monitoring is connected and the resistor overheats. If the braking resistor is not used then this trip must be disabled with bit 3 of Action <i>On Trip Detection</i> (10.037) to prevent this trip.</p> <p><b>Recommended actions:</b></p> <ul style="list-style-type: none"> <li>Check brake resistor wiring</li> <li>Check braking resistor value is greater than or equal to the minimum resistance value</li> <li>Check braking resistor insulation</li> </ul>																																																		

Trip	Diagnosis						
<b>Th Short Circuit</b>	<b>Motor thermistor short circuit</b>						
25	This trip indicates that a temperature sensor connected to an analogue input or terminal 15 on the position feedback interface has a low impedance (i.e. < 50 Ω). The cause of the trip can be identified by the sub-trip number.						
	<table border="1"> <thead> <tr> <th>Sub-trip</th> <th>Reason</th> </tr> </thead> <tbody> <tr> <td>3</td> <td><i>Analog Input 3 Mode (07.015) = 7</i> and the resistance of the thermistor connected to analog input 3 is less than 50 Ω.</td> </tr> <tr> <td>4</td> <td><i>P1 Thermistor Short Circuit Detect (03.123) = 1</i> and the resistance of the thermistor connected to the drive P1 position feedback interface is less than 50 Ω.</td> </tr> </tbody> </table>	Sub-trip	Reason	3	<i>Analog Input 3 Mode (07.015) = 7</i> and the resistance of the thermistor connected to analog input 3 is less than 50 Ω.	4	<i>P1 Thermistor Short Circuit Detect (03.123) = 1</i> and the resistance of the thermistor connected to the drive P1 position feedback interface is less than 50 Ω.
	Sub-trip	Reason					
3	<i>Analog Input 3 Mode (07.015) = 7</i> and the resistance of the thermistor connected to analog input 3 is less than 50 Ω.						
4	<i>P1 Thermistor Short Circuit Detect (03.123) = 1</i> and the resistance of the thermistor connected to the drive P1 position feedback interface is less than 50 Ω.						
<p><b>Recommended actions:</b></p> <ul style="list-style-type: none"> <li>• Check thermistor continuity</li> <li>• Replace motor / motor thermistor</li> </ul>							
<b>Thermistor</b>	<b>Motor thermistor over-temperature</b>						
24	The <i>Thermistor</i> trip indicates that the motor thermistor connected to terminal 8 (analog input 3) on the control connections or terminal 15 on the encoder terminal (15 way D-type connector) has indicated a motor over temperature. The cause of the trip can be identified by the sub-trip number						
	<table border="1"> <thead> <tr> <th>Sub-trip</th> <th>Reason</th> </tr> </thead> <tbody> <tr> <td>3</td> <td>Trip initiated from analog input 3</td> </tr> <tr> <td>4</td> <td>Trip initiated from P1 position feedback interface</td> </tr> </tbody> </table>	Sub-trip	Reason	3	Trip initiated from analog input 3	4	Trip initiated from P1 position feedback interface
	Sub-trip	Reason					
3	Trip initiated from analog input 3						
4	Trip initiated from P1 position feedback interface						
<p><b>Recommended actions:</b></p> <ul style="list-style-type: none"> <li>• Check motor temperature</li> <li>• Check threshold level (07.048)</li> <li>• Check thermistor continuity</li> </ul>							
<b>Undefined</b>	<b>Drive has tripped and the cause of the trip is Undefined</b>						
110	The <i>Undefined</i> trip indicates that the power system has generated but did not identify the trip the power system. The cause of the trip is unknown.						
	<p><b>Recommended actions:</b></p> <ul style="list-style-type: none"> <li>• Hardware fault – return the drive to the supplier</li> </ul>						
<b>User 24V</b>	<b>User 24 V supply is not present on control terminals (1,2)</b>						
91	A <i>User 24 V</i> trip is initiated, if <i>User Supply Select (Pr 06.072)</i> is set to 1 or <i>Low Under Voltage Threshold Select (06.067) = 1</i> and no user 24 V supply is present on control terminals 1 and 2.						
	<p><b>Recommended actions:</b></p> <ul style="list-style-type: none"> <li>• Ensure the user 24 V supply is present on control terminals 1 (0 V) and 2 (24 V)</li> </ul>						

Trip	Diagnosis																																																																																		
<b>User Program</b>	<b>On board user program error</b>																																																																																		
	The <i>User Program</i> trip indicates that an error has been detected in the onboard user program image. The reason for the trip can be identified by the sub-trip number.																																																																																		
	<table border="1"> <thead> <tr> <th>Sub-trip</th> <th>Reason</th> <th>Comments</th> </tr> </thead> <tbody> <tr> <td>1</td> <td>Divide by zero</td> <td></td> </tr> <tr> <td>2</td> <td>Undefined trip</td> <td></td> </tr> <tr> <td>3</td> <td>Attempted fast parameter access set-up with non-existent parameter</td> <td></td> </tr> <tr> <td>4</td> <td>Attempted access to non-existent parameter</td> <td></td> </tr> <tr> <td>5</td> <td>Attempted write to read-only parameter</td> <td></td> </tr> <tr> <td>6</td> <td>Attempted and over-range write</td> <td></td> </tr> <tr> <td>7</td> <td>Attempted read from write-only parameter</td> <td></td> </tr> <tr> <td>30</td> <td>The image has failed because either its CRC is incorrect, or there are less than 6 bytes in</td> <td>Occurs when the drive powers-up or the image is programmed. The image tasks will not run</td> </tr> <tr> <td>31</td> <td>The image requires more RAM for heap and stack than can be provided by the drive.</td> <td>As 30</td> </tr> <tr> <td>32</td> <td>The image requires an OS function call that is higher than the maximum allowed</td> <td>As 30</td> </tr> <tr> <td>33</td> <td>The ID code within the image is not valid</td> <td>As 30</td> </tr> <tr> <td>40</td> <td>The timed task has not completed in time and has been suspended</td> <td></td> </tr> <tr> <td>41</td> <td>Undefined function called, i.e. a function in the host system vector table that has not been</td> <td>As 40</td> </tr> <tr> <td>52</td> <td>Customized menu table CRC check failed</td> <td>As 30</td> </tr> <tr> <td>53</td> <td>Customized menu table changed</td> <td>Occurs when the drive powers-up or the image is programmed and the table has changed. Defaults are loaded for the derivative menu and the trip will keep occurring until drive parameters are saved.</td> </tr> <tr> <td>61</td> <td>The option module installed in slot 1 is not allowed with the derivative image</td> <td>As 30</td> </tr> <tr> <td>62</td> <td>The option module installed in slot 2 is not allowed with the derivative image</td> <td>As 30</td> </tr> <tr> <td>63</td> <td>The option module installed in slot 3 is not allowed with the derivative image</td> <td>As 30</td> </tr> <tr> <td>64</td> <td>The option module installed in slot 4 is not allowed with the derivative image</td> <td>As 30</td> </tr> <tr> <td>70</td> <td>An option module that is required by the derivative image is not installed in any slot.</td> <td>As 30</td> </tr> <tr> <td>71</td> <td>An option module specifically required to be installed in slot 1 not present</td> <td>As 30</td> </tr> <tr> <td>72</td> <td>An option module specifically required to be installed in slot 2 not present</td> <td>As 30</td> </tr> <tr> <td>73</td> <td>An option module specifically required to be installed in slot 3 not present</td> <td>As 30</td> </tr> <tr> <td>74</td> <td>An option module specifically required to be installed in slot 4 not present</td> <td>As 30</td> </tr> <tr> <td>80</td> <td>Image is not compatible with the control board</td> <td>Initiated from within the image code</td> </tr> <tr> <td>81</td> <td>Image is not compatible with the control board serial number</td> <td>As 80</td> </tr> </tbody> </table>	Sub-trip	Reason	Comments	1	Divide by zero		2	Undefined trip		3	Attempted fast parameter access set-up with non-existent parameter		4	Attempted access to non-existent parameter		5	Attempted write to read-only parameter		6	Attempted and over-range write		7	Attempted read from write-only parameter		30	The image has failed because either its CRC is incorrect, or there are less than 6 bytes in	Occurs when the drive powers-up or the image is programmed. The image tasks will not run	31	The image requires more RAM for heap and stack than can be provided by the drive.	As 30	32	The image requires an OS function call that is higher than the maximum allowed	As 30	33	The ID code within the image is not valid	As 30	40	The timed task has not completed in time and has been suspended		41	Undefined function called, i.e. a function in the host system vector table that has not been	As 40	52	Customized menu table CRC check failed	As 30	53	Customized menu table changed	Occurs when the drive powers-up or the image is programmed and the table has changed. Defaults are loaded for the derivative menu and the trip will keep occurring until drive parameters are saved.	61	The option module installed in slot 1 is not allowed with the derivative image	As 30	62	The option module installed in slot 2 is not allowed with the derivative image	As 30	63	The option module installed in slot 3 is not allowed with the derivative image	As 30	64	The option module installed in slot 4 is not allowed with the derivative image	As 30	70	An option module that is required by the derivative image is not installed in any slot.	As 30	71	An option module specifically required to be installed in slot 1 not present	As 30	72	An option module specifically required to be installed in slot 2 not present	As 30	73	An option module specifically required to be installed in slot 3 not present	As 30	74	An option module specifically required to be installed in slot 4 not present	As 30	80	Image is not compatible with the control board	Initiated from within the image code	81	Image is not compatible with the control board serial number	As 80	
Sub-trip	Reason	Comments																																																																																	
1	Divide by zero																																																																																		
2	Undefined trip																																																																																		
3	Attempted fast parameter access set-up with non-existent parameter																																																																																		
4	Attempted access to non-existent parameter																																																																																		
5	Attempted write to read-only parameter																																																																																		
6	Attempted and over-range write																																																																																		
7	Attempted read from write-only parameter																																																																																		
30	The image has failed because either its CRC is incorrect, or there are less than 6 bytes in	Occurs when the drive powers-up or the image is programmed. The image tasks will not run																																																																																	
31	The image requires more RAM for heap and stack than can be provided by the drive.	As 30																																																																																	
32	The image requires an OS function call that is higher than the maximum allowed	As 30																																																																																	
33	The ID code within the image is not valid	As 30																																																																																	
40	The timed task has not completed in time and has been suspended																																																																																		
41	Undefined function called, i.e. a function in the host system vector table that has not been	As 40																																																																																	
52	Customized menu table CRC check failed	As 30																																																																																	
53	Customized menu table changed	Occurs when the drive powers-up or the image is programmed and the table has changed. Defaults are loaded for the derivative menu and the trip will keep occurring until drive parameters are saved.																																																																																	
61	The option module installed in slot 1 is not allowed with the derivative image	As 30																																																																																	
62	The option module installed in slot 2 is not allowed with the derivative image	As 30																																																																																	
63	The option module installed in slot 3 is not allowed with the derivative image	As 30																																																																																	
64	The option module installed in slot 4 is not allowed with the derivative image	As 30																																																																																	
70	An option module that is required by the derivative image is not installed in any slot.	As 30																																																																																	
71	An option module specifically required to be installed in slot 1 not present	As 30																																																																																	
72	An option module specifically required to be installed in slot 2 not present	As 30																																																																																	
73	An option module specifically required to be installed in slot 3 not present	As 30																																																																																	
74	An option module specifically required to be installed in slot 4 not present	As 30																																																																																	
80	Image is not compatible with the control board	Initiated from within the image code																																																																																	
81	Image is not compatible with the control board serial number	As 80																																																																																	
<b>249</b>																																																																																			
<b>User Prog Trip</b>	<b>Trip generated by an onboard user program</b>																																																																																		
	This trip can be initiated from within an onboard user program using a function call which defines the sub-trip number.																																																																																		
<b>96</b>	<b>Recommended actions:</b> <ul style="list-style-type: none"> <li>Check the user program</li> </ul>																																																																																		

Trip	Diagnosis
<b>User Save</b>	<b>User Save error / not completed</b>
36	<p>The <i>User Save</i> trip indicates that an error has been detected in the user save parameters saved in non-volatile memory. For example, following a user save command, If the power to the drive was removed when the user parameters were being saved.</p> <p><b>Recommended actions:</b></p> <ul style="list-style-type: none"> <li>Perform a user save in Pr <b>mm.000</b> to ensure that the trip doesn't occur the next time the drive is powered up.</li> <li>Ensure that the drive has enough time to complete the save before removing the power to the drive.</li> </ul>
<b>User Trip</b>	<b>User generated trip</b>
41 -89 112 -159	<p>These trips are not generated by the drive and are to be used by the user to trip the drive through an application program.</p> <p><b>Recommended actions:</b></p> <ul style="list-style-type: none"> <li>Check the user program</li> </ul>
<b>User Trip 40</b>	<b>Motor Rated Current Pr 05.007 or Motor Rated Speed Pr 05.008 not recognized as valid for an LSRPM motor</b>
40	<p>If a <i>User Trip 40</i> occurs, then this indicates that the motor rated current or motor rated speed was not recognized as being a valid value for a Dyneo LSRPM motor.</p> <p><b>Recommended actions:</b></p> <ul style="list-style-type: none"> <li>If using a Dyneo LSRPM motor, check the <i>Rated Speed</i> (Pr <b>00.045</b>) and <i>Rated Current</i> (Pr <b>00.046</b>) entered in the drive against the Dyneo LSRPM motors listed in Table 6-3 to Table 6-9 . Correct the values and perform an autotune again.</li> <li>If using any other motor, set Pr <b>29.200</b> = 0 to disable the LSRPM quick setup system.</li> </ul>
<b>Voltage Range</b>	<b>Supply voltage out of range detected in Regen mode</b>
169	<p>The <i>Voltage Range</i> trip is initiated, if the <i>Regen Minimum Voltage</i> (03.026) is set to a non-zero value and the supply voltage is outside the range defined by <i>Regen Maximum Voltage</i> (03.027) and <i>Regen Minimum Voltage</i> (03.026) for more than 100 ms.</p> <p><b>Recommended actions:</b></p> <ul style="list-style-type: none"> <li>Ensure the supply voltage is operating within the drive specification.</li> <li>Ensure Pr <b>03.026</b> and Pr <b>03.027</b> are set correctly</li> <li>Check the supply voltage waveform using an oscilloscope</li> <li>Reduce the level of supply disturbance</li> <li>Set <i>Maximum Voltage</i> (03.027) to zero to disable the trip.</li> </ul>
<b>Watchdog</b>	<b>Control word watchdog has timed out</b>
30	<p>The <i>Watchdog</i> trip indicates that the control word has been enabled and has timed out</p> <p><b>Recommended actions:</b></p> <p>Once Pr <b>06.042</b> bit 14 has been changed from 0 to 1 to enable the watchdog, this must be repeated every 1s or a Watchdog trip will be initiated. The watchdog is disabled when the trip occurs and must be re-enabled if required when the trip is reset.</p>

**Table 11-4 Serial communications look up table**

No	Trip	No	Trip	No	Trip
1	Reserved 001	93	Inductor Too Hot	197	Encoder 9
2	Over Volts	94	Rectifier Set-Up	198	Phasing Error
3	OI ac	95	Reserved 95	199	Destination
4	OI Brake	96	User Prog Trip	200	Slot1 HF
5	PSU	97	Data Changing	201	Slot1 Watchdog
6	External Trip	98	Out Phase Loss	202	Slot1 Error
7	Over Speed	99	CAM	203	Slot1 Not installed
8	Inductance	100	Reset	204	Slot1 Different
9	PSU 24	101	OHT Brake	205	Slot2 HF
10	Th Brake Res	102	Reserved 102	206	Slot2 Watchdog
11	Autotune 1	103	Inter-connect	207	Slot2 Error
12	Autotune 2	104 - 108	Reserved 104 - 108	208	Slot2 Not installed
13	Autotune 3	109	OI dc	209	Slot2 Different
14	Autotune 4	110	Undefined	210	Slot3 HF
15	Autotune 5	111	Configuration	211	Slot3 Watchdog
16	Autotune 6	112 - 159	User Trip 112 - 159	212	Slot3 Error
17	Autotune 7	160	Island	213	Slot3 Not installed
18	Autotune Stopped	161 - 168	Reserved 161 - 168	214	Slot3 Different
19	Brake R Too Hot	169	Voltage Range	215	Option Disable
20	Motor Too Hot	170 - 173	Reserved 170 - 173	216	Slot App Menu
21	OHT Inverter	174	Card Slot	217	App Menu Changed
22	OHT Power	175	Card Product	218	Temp Feedback
23	OHT Control	176	Name Plate	219	An Output Calib
24	Thermistor	177	Card Boot	220	Power Data
25	Th Short Circuit	178	Card Busy	221	Stored HF
26	I/O Overload	179	Card Data Exists	222	Reserved 222
27	OHT dc bus	180	Card Option	223	Rating Mismatch
28	An Input Loss 1	181	Card Read Only	224	Drive Size
29	An Input Loss 2	182	Card Error	225	Current Offset
30	Watchdog	183	Card No Data	226	Soft Start
31	EEPROM Fail	184	Card Full	227	Sub-array RAM
32	Phase Loss	185	Card Access	228 - 246	Reserved 228 - 246
33	Resistance	186	Card Rating	247	Derivative ID
34	Keypad Mode	187	Card Drive Mode	248	Derivative Image
35	Control Word	188	Card Compare	249	User Program
36	User Save	189	Encoder 1	250	Slot4 HF
37	Power Down Save	190	Encoder 2	251	Slot4 Watchdog
38	Low Load	191	Encoder 3	252	Slot4 Error
39	Line Sync	192	Encoder 4	253	Slot4 Not installed
40 -89	User Trip 40 - 89	193	Encoder 5	254	Slot4 Different
90	Power Comms	194	Encoder 6	255	Reset Logs
91	User 24V	195	Encoder 7		
92	OI Snubber	196	Encoder 8		

The trips can be grouped into the following categories. It should be noted that a trip can only occur when the drive is not tripped or is already tripped but with a trip with a lower priority number.

**Table 11-5 Trip categories**

Priority	Category	Trips	Comments
1	Internal faults	HFxx	These indicate internal problems and cannot be reset. All drive features are inactive after any of these trips occur. If an KI-Keypad is installed it will show the trip, but the keypad will not function.
1	Stored HF trip	{Stored HF}	This trip cannot be cleared unless 1299 is entered into <i>Parameter (mm.000)</i> and a reset is initiated.
2	Non-resettable trips	Trip numbers 218 to 247, {Slot1 HF}, {Slot2 HF}, {Slot3 HF} or {Slot4 HF}	These trips cannot be reset.
3	Volatile memory failure	{EEPROM Fail}	This can only be reset if Parameter <b>mm.000</b> is set to 1233 or 1244, or if <i>Load Defaults (11.043)</i> is set to a non-zero value.
3	Internal 24 V power supply	{PSU 24V}	
4	NV Media Card trips	Trip numbers 174, 175 and 177 to 188	These trips are priority 5 during power-up.
5	Trips with extended reset times	{OI ac}, {OI Brake}, and OI dc}	These trips cannot be reset until 10 s after the trip was initiated.
5	Phase loss and DC bus power circuit protection	{Phase Loss} and {Oht dc bus}	The drive will attempt to stop the motor before tripping if a {Phase Loss}.000 trip occurs unless this feature has been disabled (see <i>Action On Trip Detection (10.037)</i> ). The drive will always attempt to stop the motor before tripping if an {Oht dc bus} occurs.
5	Standard trips	All other trips	

## 11.5 Internal / Hardware trips

Trips {HF01} to {HF25} are internal faults that do not have trip numbers. If one of these trips occurs, the main drive processor has detected an irrecoverable error. All drive functions are stopped and the trip message will be displayed on the drive keypad. If a non permanent trip occurs this may be reset by power cycling the drive. On power up after it has been power cycled the drive will trip on Stored HF. The sub-trip code is the number of the original HF trip. Enter 1299 in **mm.000** to clear the Stored HF trip.

## 11.6 Alarm indications

In any mode, an alarm is an indication given on the display by alternating the alarm string with the drive status string on the first row and showing the alarm symbol in the last character in the first row. If an action is not taken to eliminate any alarm except "Auto Tune and Limit Switch" the drive may eventually trip. Alarms are not displayed when a parameter is being edited, but the user will still see the alarm character on the upper row.

Table 11-6 Alarm indications

Alarm string	Description
<b>Brake Resistor</b>	Brake resistor overload. <i>Braking Resistor Thermal Accumulator</i> (10.039) in the drive has reached 75.0 % of the value at which the drive will trip.
<b>Motor Overload</b>	<i>Motor Protection Accumulator</i> (04.019) in the drive has reached 75.0 % of the value at which the drive will trip and the load on the drive is >100 %.
<b>Ind Overload</b>	Regen inductor overload. <i>Inductor Protection Accumulator</i> (04.019) in the drive has reached 75.0 % of the value at which the drive will trip and the load on the drive is >100 %.
<b>Drive Overload</b>	Drive over temperature. <i>Percentage Of Drive Thermal Trip Level</i> (07.036) in the drive is greater than 90 %.
<b>Auto Tune</b>	The autotune procedure has been initialized and an autotune in progress.
<b>Limit Switch</b>	Limit switch active. Indicates that a limit switch is active and that is causing the motor to be stopped.

## 11.7 Status indications

Table 11-7 Status indications

Upper row string	Description	Drive output stage
<b>Inhibit</b>	The drive is inhibited and cannot be run. The Safe Torque Off signal is not applied to Safe Torque Off terminals or Pr <b>06.015</b> is set to 0	Disabled
<b>Ready</b>	The drive is ready to run. The drive enable is active, but the drive inverter is not active because the final drive run is not active	Disabled
<b>Stop</b>	The drive is stopped / holding zero speed.	Enabled
<b>Run</b>	The drive is active and running	Enabled
<b>Scan</b>	The drive is enabled in Regen mode and is trying to synchronize to the supply	Enabled
<b>Supply Loss</b>	Supply loss condition has been detected	Enabled
<b>Deceleration</b>	The motor is being decelerated to zero speed / frequency because the final drive run has been deactivated.	Enabled
<b>dc injection</b>	The drive is applying dc injection braking	Enabled
<b>Position</b>	Positioning / position control is active during an orientation stop	Enabled
<b>Trip</b>	The drive has tripped and no longer controlling the motor. The trip code appears in the lower display	Disabled
<b>Active</b>	The regen unit is enabled and synchronized to the supply	Enabled
<b>Under Voltage</b>	The drive is in the under voltage state either in low voltage or high voltage mode	Disabled
<b>Heat</b>	The motor pre-heat function is active	Enabled
<b>Phasing</b>	The drive is performing a 'phasing test on enable'.	Enabled

**Table 11-8 Option module and NV Media Card and other status indications at power-up**

First row string	Second row string	Status
<b>Booting</b>	<b>Parameters</b>	Parameters are being loaded
Drive parameters are being loaded from a NV Media Card		
<b>Booting</b>	<b>User Program</b>	User program being loaded
User program is being loaded from a NV Media Card to the drive		
<b>Booting</b>	<b>Option Program</b>	User program being loaded
User program is being loaded from a NV Media Card to the option module in slot X		
<b>Writing To</b>	<b>NV Card</b>	Data being written to NV Media Card
Data is being written to a NV Media Card to ensure that its copy of the drive parameters is correct because the drive is in Auto or Boot mode		
<b>Waiting For</b>	<b>Power System</b>	Waiting for power stage
The drive is waiting for the processor in the power stage to respond after power-up		
<b>Waiting For</b>	<b>Options</b>	Waiting for an option module
The drive is waiting for the Options Modules to respond after power-up		
<b>Uploading From</b>	<b>Options</b>	Loading parameter database
At power-up it may be necessary to update the parameter database held by the drive because an option module has changed or because an applications module has requested changes to the parameter structure. This may involve data transfer between the drive an option modules. During this period 'Uploading From Options' is displayed		

## 11.8 Programming error indications

The following are the error messages displayed on the drive keypad when an error occurs during programming of drive firmware.

**Table 11-9 Programming error indications**

Error String	Reason	Solution
<b>Error 1</b>	There is not enough drive memory requested by all the option modules.	Power down drive and remove some of the option modules until the message disappears.
<b>Error 2</b>	At least one option module did not acknowledge the reset request.	Power cycle drive
<b>Error 3</b>	The boot loader failed to erase the processor flash	Power cycle drive and try again. If problem persists, return drive
<b>Error 4</b>	The boot loader failed to program the processor flash	Power cycle drive and try again. If problem persists, return drive
<b>Error 5</b>	One option module did not initialize correctly. Option module did not set Ready to Run flag.	Remove faulty option module.

## 11.9 Displaying the trip history

The drive retains a log of the last ten trips that have occurred. *Trip 0* (10.020) to *Trip 9* (10.029) store the most recent 10 trips that have occurred where *Trip 0* (10.020) is the most recent and *Trip 9* (10.029) is the oldest. When a new trip occurs it is written to *Trip 0* (10.020) and all the other trips move down the log, with oldest being lost. The date and time when each trip occurs are also stored in the date and time log, i.e. *Trip 0 Date* (10.041) to *Trip 9 Time* (10.060). The date and time are taken from *Date* (06.016) and *Time* (06.017). The date / time source can be selected with *Date / Time Selector* (06.019). Some trips have sub-trip numbers which give more detail about the reason for the trip. If a trip has a sub-trip number its value is stored in the sub-trip log, i.e. *Trip 0 Sub-trip Number* (10.070) to *Trip 9 Sub-trip Number* (10.079). If the trip does not have a sub-trip number then zero is stored in the sub-trip log.

If any parameter between Pr 10.020 and Pr 10.029 inclusive is read by serial communication, then the trip number in Table 11-4 is the value transmitted.

### NOTE

The trip logs can be reset by writing a value of 255 in Pr 10.038.

## 11.10 Behavior of the drive when tripped

If the drive trips, the output of the drive is disabled so the load coasts to a stop. If any trip occurs the following read only parameters are frozen until the trip is cleared. This is to help in diagnose the cause of the trip.

Parameter	Description
<b>01.001</b>	Frequency / speed reference
<b>01.002</b>	Pre-skip filter reference
<b>01.003</b>	Pre-ramp reference
<b>02.001</b>	Post-ramp reference
<b>03.001</b>	Final speed ref
<b>03.002</b>	Speed feedback
<b>03.003</b>	Speed error
<b>03.004</b>	Speed controller output
<b>04.001</b>	Current magnitude
<b>04.002</b>	Active current
<b>04.017</b>	Reactive current
<b>05.001</b>	Output frequency
<b>05.002</b>	Output voltage
<b>05.003</b>	Power
<b>05.005</b>	DC bus voltage
<b>07.001</b>	Analog input 1
<b>07.002</b>	Analog input 2
<b>07.003</b>	Analog input 3

If the parameters are not required to be frozen then this can be disabled by setting bit 4 of Pr 10.037.

## 12 UL Information

### 12.1 UL file reference

All products covered by this Guide are UL Listed to both Canadian and US requirements. The UL file reference is: NMMS/7.E171230. Products that incorporate the Safe Torque Off function have been investigated by UL. The UL file reference is: FSPC.E171230.

### 12.2 Option modules, kits and accessories

All Option Modules, Control Pods and Installation Kits supplied by Nidec Industrial Automation for use with these drives are UL Listed.

### 12.3 Enclosure ratings

Drives are UL Open Type as supplied.

Drives fitted with a conduit box are UL Type 1.

Drives that are capable of through-hole mounting are UL Type 12 when installed with the high-IP insert (where provided), and the Type 12 sealing kit to prevent ingress of dust and water.

Remote Keypads are UL Type 12.

### 12.4 Mounting

Drives can be mounted directly onto a vertical surface. This is known as 'surface' or 'standard' mounting. Refer to the relevant *Power Installation Guide* for further information.

Drives can be installed side by side with recommended spacing between them. This is known as 'bookcase' mounting. Refer to the relevant *Power Installation Guide* for further information.

Some drives can be mounted on their side. This is known as 'tile' mounting. Suitable tile mounting kits are available from Nidec Industrial Automation. Refer to the relevant *Power Installation Guide* for further information.

Drives fitted with a conduit box can be mounted directly onto a wall or other vertical surface without additional protection. Suitable conduit boxes are available from Nidec Industrial Automation.

Some drives may be through-hole mounted. Mounting brackets and sealing kits are available from Nidec Industrial Automation. Refer to the relevant *Power Installation Guide* for further information.

Remote Keypads can be mounted on the outside of a UL Type 12 enclosure. A sealing and mounting kit is provided with the keypad.

### 12.5 Environment

Drives must be installed in a Pollution Degree 2 environment or better (dry, non-conductive pollution only).

All drives are capable of delivering full rated output current at surrounding air temperatures up to 40 °C

Drives with model numbers beginning M100, M101, M200, M201, M300 or M400, with frame sizes 1 to 4 may be operated in surrounding air temperatures up to 50 °C at de-rated current. All other drives, for example M600, M700, M701, M702 etc. may be operated in surrounding air temperatures up to 55 °C at de-rated current.

### 12.6 Electrical Installation

#### TERMINAL TORQUE

Terminals must be tightened to the rated torque as specified in the Installation Instructions. Refer to the relevant *Power Installation Guide* for further information.

#### WIRING TERMINALS

Drives must be installed using cables rated for 75 °C operation, copper wire only.

#### GROUND CONNECTION INSTRUCTIONS

UL Listed closed-loop connectors sized according to the field wiring shall be used for grounding. Refer to the relevant *Power Installation Guide* for further information.

#### BRANCH CIRCUIT PROTECTION

The fuses and circuit breakers required for branch circuit protection are contained in the Installation Instructions.

#### OPENING OF BRANCH CIRCUIT

Opening of the branch-circuit protective device may be an indication that a fault has been interrupted. To reduce the risk of fire or electric shock, the equipment should be examined and replaced if damaged. If burnout of the current element of an overload relay occurs, the complete overload relay must be replaced.

Integral solid state short circuit protection does not provide branch circuit protection. Branch circuit protection must be provided in accordance with the National Electrical Code and any additional local "codes".

#### DYNAMIC BRAKING

Drives with model numbers beginning M100, M101, M200, M201, M300 or M400, with frame sizes 1 to 4 have been evaluated for dynamic braking applications.

All other drives have not been evaluated for dynamic braking.

## 12.7 Motor overload protection and thermal memory retention

All drives incorporate internal overload protection for the motor load that does not require the use of an external or remote overload protection device.

The protection level is adjustable and the method of adjustment is provided in section 7.4 *Motor thermal protection* on page 89. Maximum current overload is dependent on the values entered into the current limit parameters (motoring current limit, regenerative current limit and symmetrical current limit entered as percentage) and the motor rated current parameter (entered in amperes).

The duration of the overload is dependent on motor thermal time constant (variable up to a maximum of 3000 seconds). The default overload protection is set such that the product is capable of 150 % of the current value entered into the motor rated current parameter for 60 seconds.

The drives are provided with user terminals that can be connected to a motor thermistor to protect the motor from high temperature, in the event of a motor cooling fan failure.

The method of adjustment of the overload protection is provided in the Installation Instructions shipped with the product.

All models are provided with thermal memory retention.

## 12.8 Electrical supply

The drives are suitable for use on a circuit capable of delivering not more than 100,000 RMS Symmetrical Amperes, at rated voltage when protected by fuses as specified in the Installation Instructions.

Some smaller drives are suitable for use on a circuit capable of delivering not more than 10,000 RMS Symmetrical Amperes, at rated voltage when protected by circuit breakers as specified in the Installation Instructions.

## 12.9 External Class 2 supply

The external power supply used to power the 24 V control circuit shall be marked: "UL Class 2". The power supply voltage shall not exceed 24 Vdc.

## 12.10 Requirement for Transient Surge Suppression

This requirement applies to drives with rated input voltage = 575 V, Frame Size 7 only.

TRANSIENT SURGE SUPPRESSION SHALL BE INSTALLED ON THE LINE SIDE OF THIS EQUIPMENT AND SHALL BE RATED 575 Vac (PHASE TO GROUND), 575 Vac (PHASE TO PHASE), SUITABLE FOR OVERVOLTAGE CATEGORY III, AND SHALL PROVIDE PROTECTION FOR A RATED IMPULSE VOLTAGE TO WITHSTAND VOLTAGE PEAK OF 6 kV AND A CLAMPING VOLTAGE OF MAXIMUM 2400 V.

## 12.11 Group Installation and Modular Drive Systems

Drives with DC+ and DC- supply connections, with 230 V or 480 V supply voltage rating, are UL approved for use in modular drive systems as inverters when supplied by the converter sections: Mentor MP25A, 45A, 75A, 105A, 155A or 210A range manufactured by Nidec Industrial Automation.

Alternatively, the inverters may be supplied by converters from the Unidrive-M range manufactured by Nidec Industrial Automation.

In these applications the inverters are required to be additionally protected by supplemental fuses.

Drives have not been evaluated for other Group Installation applications, for example where a single inverter is wired directly to two or more motors. In these applications, additional thermal overload protection is needed. Contact Nidec Industrial Automation for further details.

## 12.12 cUL requirements for 575 V frame size 7 and 8

For size 7 and 8 575 Vac models only (07500440, 07500550, 08500630, 08500860), the following must be adhered to in order to comply with cUL approval requirements:

TRANSIENT SURGE SUPPRESSION SHALL BE INSTALLED ON THE LINE SIDE OF THIS EQUIPMENT AND SHALL BE RATED 575 Vac (PHASE TO GROUND), 575 Vac (PHASE TO PHASE), SUITABLE FOR OVERVOLTAGE CATEGORY III, AND SHALL PROVIDE PROTECTION FOR A RATED IMPULSE WITHSTAND VOLTAGE PEAK OF 6 kV AND A CLAMPING VOLTAGE OF MAXIMUM 2400 V.

---

# Index

---

## Symbols

+10V user output .....	24
+24V external input .....	21, 24, 27
+24V user output .....	26

## Numerics

0V .....	27
0V common .....	24

## A

Acceleration .....	46, 64, 65, 66, 67, 68
Advanced menus .....	33
Advanced parameters .....	106
Alarm .....	211
Alarm Indications .....	211
Analog input 2 .....	25
Analog input 3 .....	25
Analog output 1 .....	26
Analog output 2 .....	26
Autotune .....	78

## B

Basic requirements .....	59
--------------------------	----

## C

Cautions .....	9
Control connections .....	23
Control terminal specification .....	24
Current limit .....	46
Current limits .....	89
Current loop gains .....	87

## D

Deceleration .....	49, 64, 65, 66, 67, 68
Defaults (restoring parameter) .....	36
Destination parameter .....	23
Diagnostics .....	183
Digital I/O 1 .....	26
Digital I/O 2 .....	26
Digital I/O 3 .....	26
Digital Input 4 .....	26
Digital Input 5 .....	26
Digital Input 6 .....	26
Display .....	30
Display messages .....	34
Drive enable .....	27

## F

Field weakening (constant power) operation .....	90
Fixed V/F mode .....	13

## G

Getting Started .....	30
-----------------------	----

## H

High speed operation .....	90
----------------------------	----

## I

Internal / Hardware trips .....	211
---------------------------------	-----

## K

Keypad and display - Installing / removing .....	19
Keypad operation .....	30

## M

Maximum speed / frequency .....	91
Mechanical Installation .....	18
Menu 0 .....	33
Menu 01 - Frequency / speed reference .....	120
Menu 02 - Ramps .....	124
Menu 03 - Slave frequency, speed feedback and speed control .....	127
Menu 04 - Torque and current control .....	131
Menu 05 - Motor control .....	135
Menu 06 - Sequencer and clock .....	140
Menu 07 - Analog I/O .....	144
Menu 08 - Digital I/O .....	148
Menu 09 - Programmable logic, motorized pot and binary sum .....	152
Menu 10 - Status and trips .....	158
Menu 11 - General drive set-up .....	160
Menu 12 - Threshold detectors and variable selectors .....	162
Menu 13 - Position control .....	170
Menu 14 - User PID controller .....	174
Menu 18 - Application menu 1 .....	178
Menu 19 - Application menu 2 .....	178
Menu 20 - Application menu 3 .....	178
Menu 21 - Second motor parameters .....	179
Menu 22 - Additional Menu 0 set-up .....	181
Menu structure .....	32
Minimum connections to get the motor running in any operating mode .....	60
Mode parameter .....	23
Monitoring .....	48
Motor (running the motor) .....	59
Motor number of poles .....	77
Motor parameters .....	54
Motor rated current .....	77
Motor rated current (maximum) .....	89
Motor rated frequency .....	77
Motor rated power factor .....	77
Motor rated speed .....	77
Motor rated voltage .....	77
Motor thermal protection .....	89

## N

Notes .....	9
NV media card operation .....	99

## O

Onboard PLC .....	104
Open loop mode .....	13
Open loop vector mode .....	13
Operating mode (changing) .....	35, 59
Operating modes .....	13
Operating-mode selection .....	55
Optimization .....	77
Option Module .....	177
Option Module - Installing / removing .....	18
Options .....	15

## P

Parameter access level .....	36
Parameter ranges .....	109
Parameter security .....	36
Parameter x.00 .....	46
Position feedback module category parameters .....	177
Precision reference Analog input 1 .....	25
Product information .....	11

## Q

Quadratic V/F mode .....	13
Quick start commissioning / Start-up .....	64
Quick start connections .....	59

## R

Ramps .....	46
Regen mode .....	13
Relay contacts .....	27
RFC-A mode .....	13
RFC-S mode .....	13

## S

Safe Torque Off .....	28
Safe Torque Off/drive enable .....	27
Safety Information .....	9
Saving parameters .....	35
Serial comms lead .....	22
Serial communications connections .....	22
Serial communications look-up table .....	209
Single line descriptions .....	39
Source parameter .....	23
Speed loop gains .....	83, 86, 88
Speed reference selection .....	46
Speed-loop PID gains .....	47
Status .....	211
Status Indications .....	211
Status information .....	55
Switching frequency .....	90

## T

Trip .....	183
Trip History .....	212
Trip Indications .....	183
Trips, Sub-trip numbers .....	185

## U

UL listed accessories .....	213
UL Listing Information .....	213
User Security .....	36

## V

Voltage boost .....	47
Voltage mode .....	78, 79

## W

Warnings .....	9
----------------	---





**0478-0337-02**